

JKF8 Intelligent Low-Voltage Reactive Power Compensation Controller

1. General

JKF8 Intelligent Low-Voltage Reactive Power Compensation Controller (hereinafter referred to as "controller") is a dedicated controller which can make compensations for the reactive power of low voltage distribution system.

2. Type designation

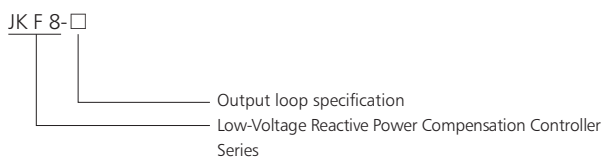

3. Features

- 3.1 With combined control on reactive power and power factor, a reliable input can be ensured under low load, and surge switching can be prevented.
- 3.2 Real-time display of the network status, including parameters such as power factor, voltage, current, active power, and reactive power, etc.
- 3.3 The polarity of the sampling signal can be automatically identified. Therefore, there is no need to worry about wrong connections with reversed polarity.
- 3.4 In case the voltage of the electrical power network is lower than 300 V, or exceeds the preset over-voltage protection value, the connected capacitor banks will be automatically and rapidly (5 sec.) disconnected in steps, and the voltage value will be displayed.
- 3.5 In case the signal from the secondary coil of the current transformer is smaller than 150 mA, the controller will prevent any more capacitor from being connected, in the mean time, automatically and rapidly (5 sec.) disconnect the connected capacitor banks step-wise.
- 3.6 Switching (opening/closing control of the contactor) prevention time for the same group of capacitors is 3 minutes (capacitor discharge duration)
- 3.7 The controller is with cyclic automated-self-test function, which facilitates the factory acceptance test for a capacitor panel.



4. Operation Conditions

- 4.1 Ambient temperature: $-10^{\circ}\text{C} \sim +40^{\circ}\text{C}$
- 4.2 Relative humidity: $\leq 50\%$, when 40°C , $\leq 90\%$ when 20°C
- 4.3 Altitude: $\leq 2000\text{ m}$
- 4.4 Operation environment: free of hazardous gas and/or vapor, conductive or explosive dust, or rigorous mechanical vibration..
- 4.5 Operation voltage: $400\text{ V} + 10\%$

5. Technical Specifications

Parameters	Technical Specifications
Sampling voltage	400VAC±10%
Sampling current	150mA~5 A
Rated frequency	50/60Hz±5%
Low-current capacitor connection prevention	≤150 mA
Current transformation ratio	Range of transformation ratio for sampling current transformer: 5~800, Preset value of the ratio (preset value in factory: 60, which means 300/5)
Time lag	5~120 seconds (preset value in factory: 30 seconds)
Preset mode	Full automation mode (displayed code F-0: 1): no need to set the capacitor connection threshold or the capacitor disconnection threshold. Manual setup mode(displayed code F-0: 0): need to set the capacitor connection threshold and the capacitor disconnection threshold manually.
Capacitor connection threshold	Full automation mode: capacitor banks in the smallest step Manual mode: preset value for reactive power: 1~120 kvar (preset value in factory: 10 kvar)
Capacitor disconnection threshold	Power factor, 0.85 ~ -0.95 continuously adjustable (preset value in factory: 1.00)
Over-voltage threshold	400 V~456 V (preset value in factory: 430 V)
Loop number	JKF8-6 (loop number can be set between 1 and 6), JKF8-12(loop number can be set between 1 and 12)
Operation mode	Automated cyclic opening/closing control & manual operation
Max. power consumption	15 W
Output contact point capacity	5A/230V(or 3A/400V)
Weight	Approximately 1.5 Kg

6. Wiring Diagram

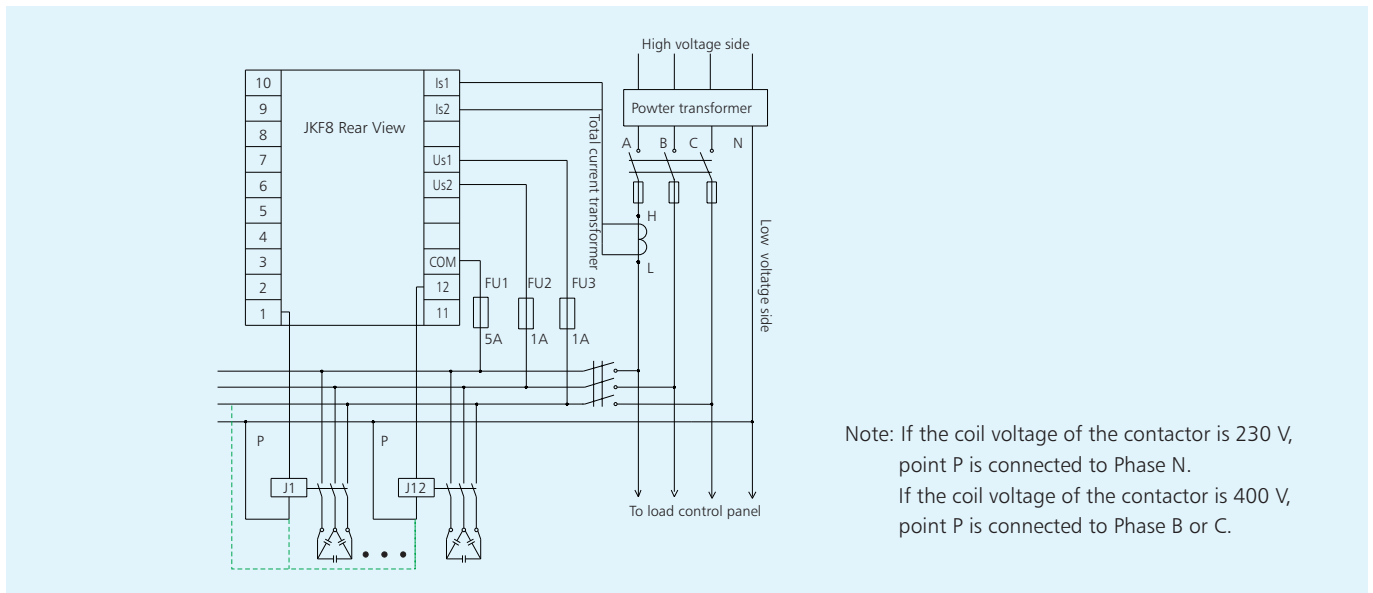

- 6.1 Connection terminal US1 and US2 are to be connected to the sampling voltage. AC 400 V shall be connected.
- 6.2 Terminal IS1 and IS2 are to be connected to the sampling current, which shall be sampled from the transformed current generated by the current transformer for the load, and which shall not be in-phase with US1 and US2 (if A is for current, then B and C are for voltage).
- 6.3 Terminal COM is the common shared terminal to be connected to number 1 to 12 relays in the output lines of the controller, and each of the terminals 1~12 is to be connected to the output control line to control the respective contactor in the respective compensation loop of the capacitor panel.
- 6.4 If the coil voltage of the contactor J is 230 V, then Point P is connected to Phase N. If the coil voltage of the contactor J is 400 V, then Point P is connected to Phase C (as long as it is not in-phase with terminal COM).
- 6.5 FU1~3 are to be connected to fusers which are supplied by the user.

7. Description of Parameters

7.1 Description of dynamic parameters

Code	Signification	Unit	Description
I	Current	A	If the measured value is out of the display range, the approximate value will be displayed, e.g., 1260 A is displayed as E13
U	Voltage	V	Display the measured voltage value
Q	Reactive power	Kvar	If the measured value is out of the display range, the approximate value will be displayed, e.g., 1360 Kvar is displayed as E14.
P	Active power	KW	If the measured value is out of the display range, the approximate value will be displayed, e.g., 1360 kW is displayed as E14.

7.2 Description of preset parameters (menu description)

Code	Description	Range of Settings	Factory Settings	Change Step	Remark
F-0	Preset mode	1 or 0	1	—	1 full automation 0 manual setup
F-1	Capacitor connection threshold	1~120 kvar	10 kvar	1 kvar	This parameter is invalid under the full automation mode
F-2	Target power factor	0.85~0.95	1.00	0.01	“-” stands for system capacity
F-3	Switching time lag	5~120 sec .	30 sec.	1 sec.	
F-4	Over-voltage protection	400 V~456 V	430 V	2 V	Voltage difference: 8~10V
F-5	Number of control loop	1~6 or 1~12	6 or 12	1	Two types of specifications
F-6	Transformation ratio of the sampling current transformer	5~800	60	5	(300: 5)

8. Overall and Mounting Dimension (mm)

