

OCP Connector

(MINI-MCC Bus Connector)

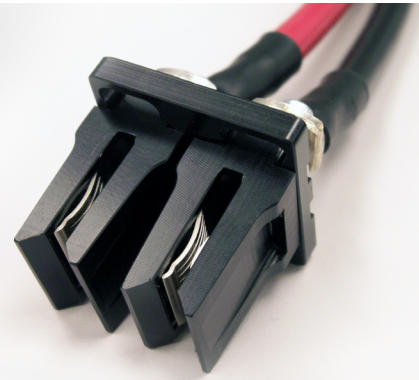

The OCP (Open Compute Project) Connector is a bus bar to cable power interconnection developed for use in Open Compute System applications. The connector sides are open allowing unbounded connection along bus-bar lengths. The connector is single pole and mounted in pairs to provide current loop connection. Mating lead-in is load-pluggable rated for 105 Amp current interruption using typical nickel, silver or gold surface plate.

Individualized contact bands are low resistance providing low voltage drop through the connection.

- High Current Capacity of 130 Amps
- Hot / Load Pluggable
- Low Voltage Drop
- UL 1977 Standard Compliant
- CSA Standard C22.2 No. 182.3-M1987 Compliant
- RoHS Compliant

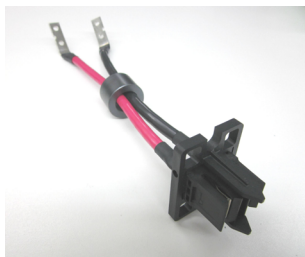

CONNECTOR SPECIFICATIONS

Materials & Finish

Insulator	Polyester (PBT), UL 94 V-0
Contact	Copper Beryllium Alloy, Nickel Plated
Crimp Termination	Copper Beryllium Alloy, Nickel Plated
Crimp Barrel Cover	Brass Copper Alloy

Mechanical

Insertion Force	12N (1.2 kgf) Typical
-----------------	-----------------------

Electrical Ratings

Maximum Operating Current	130 A
Operating Current at 30°C T-Rise	105 A
Insulator Voltage	600 VAC / 850 VDC
Load Pluggable Current	105 A at 24 V Open Circuit
Operating Current Through 6 AWG Wire	85 A at 30°C T-Rise

Environmental

Maximum Operating Temperature	130°C
Storage Temperature	-40°C to 130°C

REGULATORY SPECIFICATIONS

The OCP Connector (MINI-MCC Bus Connector) complies with UL safety regulatory requirements including current interruption and arcing without compromising connection reliability.

SAFETY: UL 1977, CSA Standard C22.2 No. 182.3-M1987 (UL File Number E303434)

RoHS: IEC Directive 2002/95/EC

ELECTRICAL PERFORMANCE

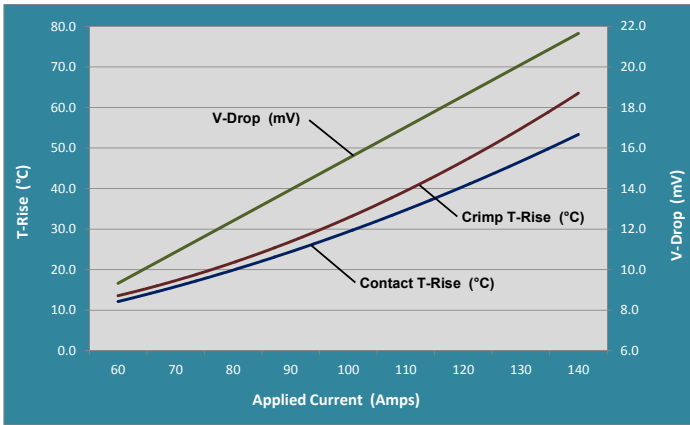

Test Conditions:

Normalized graph shows OCP Connector electrical performance for temperature rise and voltage drop from 60 amps to 140 amps. The connector is mated to nickel plated copper conductor 3 mm x 38.1 mm, and the termination is through the crimp barrel to single 6 AWG stranded wire.

OCP CONNECTOR DRAWING

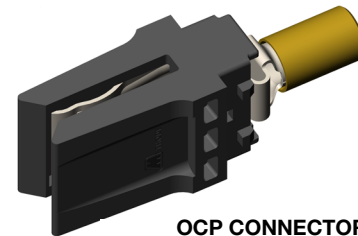
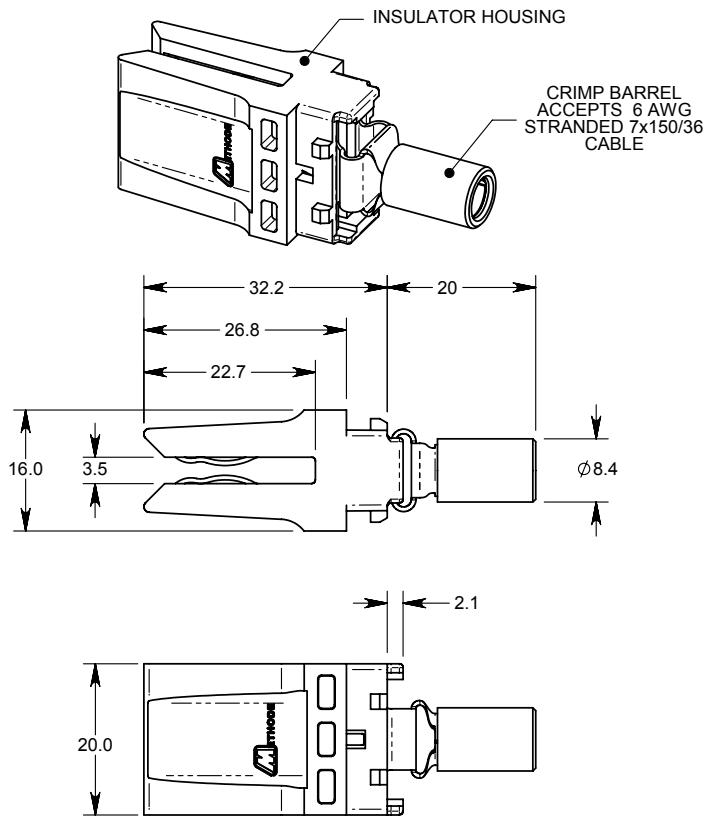

**OCP CONNECTOR
(MINI-MCC BUS CONNECTOR)
Part Number: 5301-07278-00107**

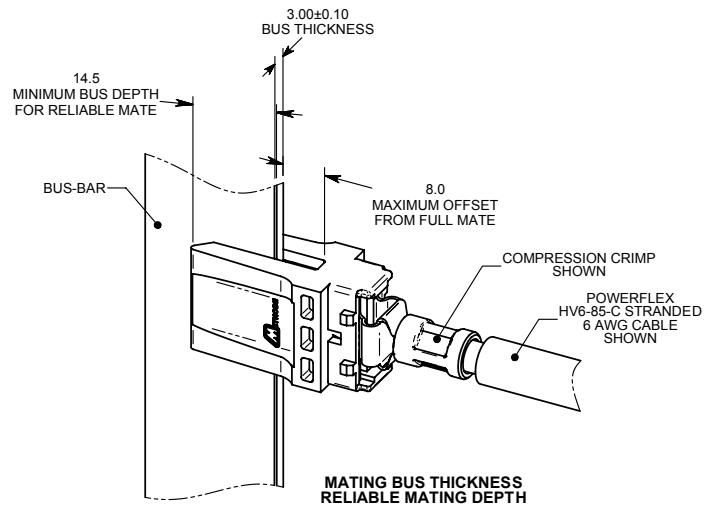

ORDERING INFORMATION

**OCP Connector (MINI-MCC Bus Connector)
Part Number: 5301-07278-00107**

sales@methode.com
(847) 577-9545

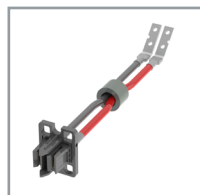

APPLICATION EXAMPLE

**Open Compute Project Connector Module
Part Number: 5313-07450-00107**
Drawing is available on the [Methode website](http://www.methode.com) or by contacting Methode at sales@methode.com