

TGP-751 TGP-651

ThermoGenerator-Package (TGP)

Thin Film Thermogenerator
inside standard package

Preliminary Datasheet

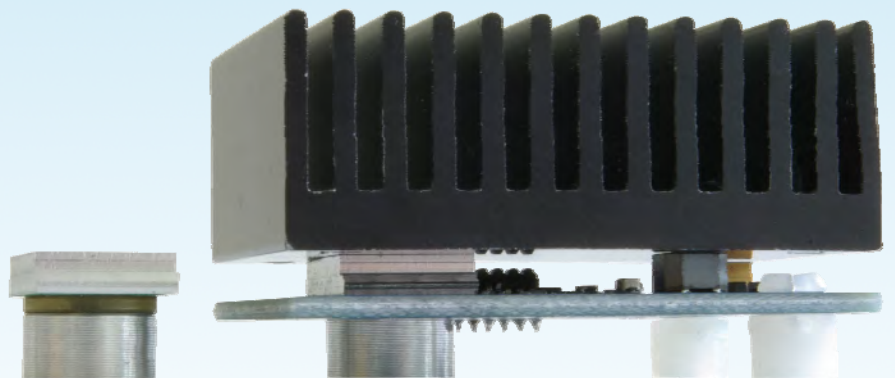
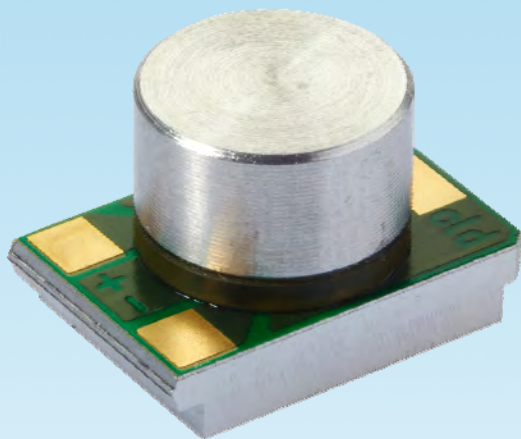

Important Notices – Please read carefully prior to use**Micropelt Products are prototypes**

Micropelt supplies *thermoelectric* coolers and *thermogenerators in package*, as well as *energy harvesting modules* (hereinafter referred to as "Prototype Products"). The Prototype Products distributed by Micropelt to date are prototypes that have not yet been released to manufacturing and marketing for regular use by end-users. The Prototype Products are still being optimized and continuously tested. As such, the Prototype Products may not fully comply with design-, marketing-, and/or manufacturing-related protective considerations, including product safety and environmental measures typically found in end products that incorporate such semiconductor components or circuit boards.

In addition, the Products have not yet been fully tested for compliance with the limits of computing devices, neither pursuant to part 15 of FCC rules nor pursuant to any other national or international standards, which are designed to provide reasonable protection against radio frequency interference.

Use of Products restricted to demonstration, testing and evaluation

Micropelt's Prototype Products are intended exclusively for the use for demonstration, testing and evaluation purposes.

The Prototype Products must not be used productively. In particular, the Prototype Products must not be used in any safety-critical applications, such as (but not limited to) life support systems, near explosion endangered sites, and/or any other performance critical systems.

The Prototype Products must only be handled by professionals in the field of electronics and engineering who are experienced in observing good engineering standards and practices.

Further information please find on page 14 in this datasheet. Please read carefully prior to use.

TGP-751 / TGP-651

ThermoGenerator-Package

1. Introduction

1.1 General description

The TGP-751 / TGP-651 is a packaged Micropelt thermogenerator, which offers the superior performance of Micropelt's thin-film, solid-state generators in a standard packaging concept.

Micropelt's thermogenerator chips offer a very high power density, with up to 100 leg pairs per mm², and a very high output voltage of up to 1.75 V per Watt of thermal input.

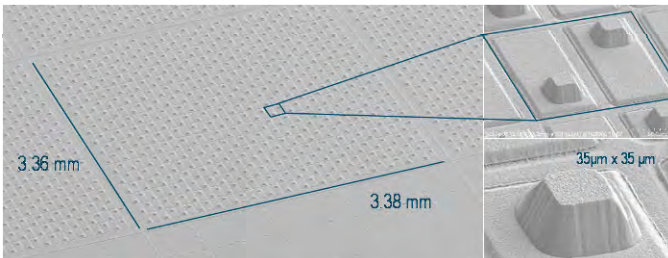

Thermoelectric legs pairs on wafer substrate

The package concept is based on a rectangle metal-base laminate with a ring isolator, in order to achieve a good thermal performance by maximizing the thermal flow through the Micropelt thermogenerator chip. Together with a metal top, the components offer a solid and stable mechanical construction.

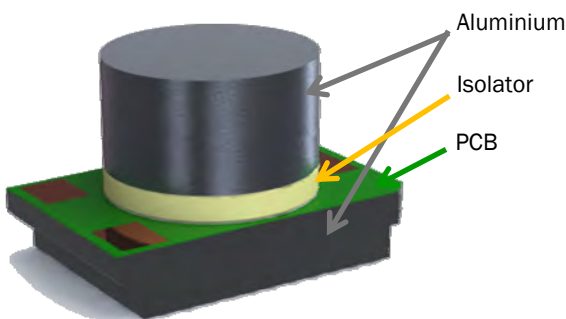

Solid and stable mechanical construction

1.2 Features:

- Integrates Micropelt MPG-D751 or MPG-D651 solid-state thermogenerator
- Maintenance-free solid state operation
- Long life time
- Compatible with automated placing & reflow production lines
- TGP thickness offers adequate spacing for placing components on the PCB
- Optimized mechanical design offers maximum thermal performance
- Operating temperatures up to 100 °C
- High output voltage per degree temperature gradient (110 mV/K for TGP-751)

	TGP-751	TGP-651
Relec	300 Ω	185 Ω
R thermal (R-th)	18 K/W	28 K/W
Seebeck voltage	110 mV/K	60 mV/K
TEG inside	MPG-D751	MPG-D651
Footprint (l x w)	15 x 10 mm	15 x 10 mm

1.3 Applications

Generic power supply utilizing waste heat to drive Milliwatt (wireless) applications, including:

- Wireless sensor networks (WSN)
- Industrial process monitoring
- Condition monitoring
- Thermal event logging
- Thermal triggering
- Intelligent buildings and HVAC
- Automatic meter reading (AMR)
- Energy monitoring & control

TGP-751 / TGP-651

ThermoGenerator-Package

1.4 Typical application diagram

Electrical diagram of a DC Booster (refer Micropelt TE-CORE module datasheet), which up-converts the TGP output voltage to 1.9 V - 4.5 V (configurable).

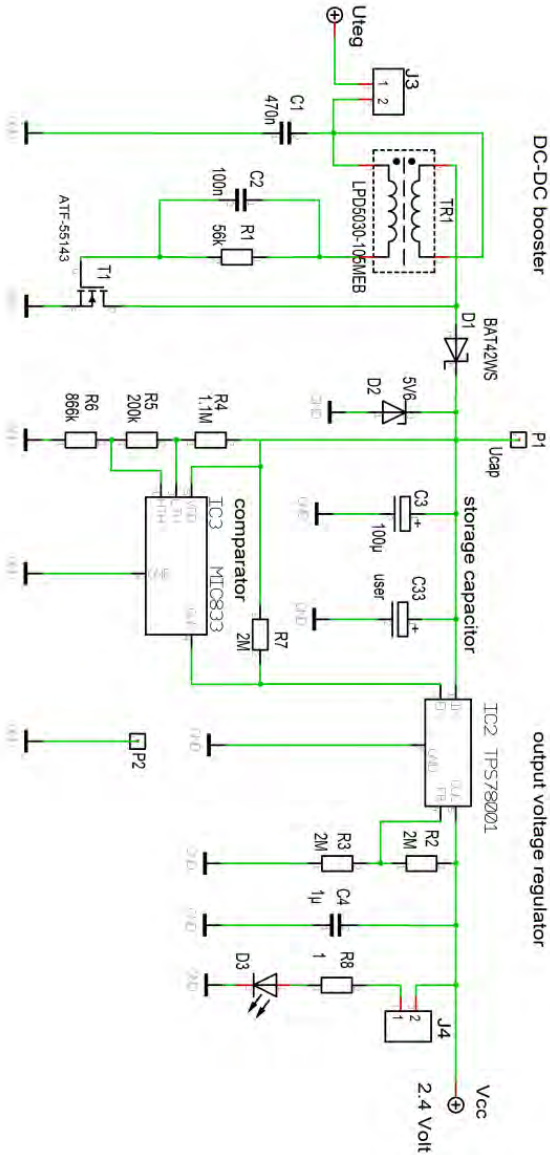

DC booster concept, as used for Micropelt TE-CORE thermoharvesting power module

1.5 Typical thermal application

The TGP can be integrated into a standard (FR4) PCB via a through hole for the thermal path. This allows a mechanical construction for the hot and cold side of the thermal harvester power source, with an optimum thermal performance.

The Micropelt TE-CORE module operates from a heat source versus ambient air with heatsink.

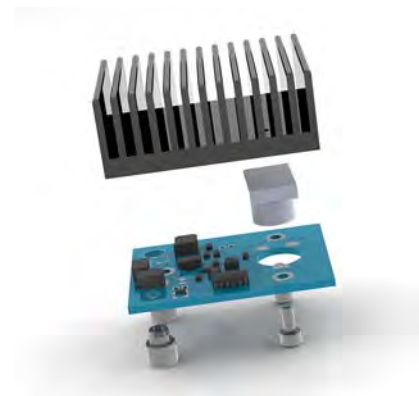

Micropelt TE-CORE thermoharvesting module with integrated TGP, DC-Booster, power management and heatsink

1.6 Absolute Maximum Ratings

	min	TYP	max
TGP-751			
R thermal		18 K/W	
Seebeck voltage		110 mV/K ($T_{amb} = 25\text{ }^{\circ}\text{C}$)	
R electrical	240 Ω	300 Ω ($T_{amb} = 25\text{ }^{\circ}\text{C}$)	350 Ω
TGP-651			
R thermal		28 K/W	
Seebeck voltage		60 mV/K / ($T_{amb} = 25\text{ }^{\circ}\text{C}$)	
R electrical	120 Ω	185 Ω ($T_{amb} = 25\text{ }^{\circ}\text{C}$)	230 Ω
General			
ESD sensitivity			9000 V
Soldering temperature *			260 $^{\circ}\text{C}$
Allowable reflow cycles *			3
Hot side temp	+ 10 $^{\circ}\text{C}$		+ 100 $^{\circ}\text{C}$
ambient temp	- 0 $^{\circ}\text{C}$		+ 85 $^{\circ}\text{C}$
Storage temp	- 20 $^{\circ}\text{C}$		+ 120 $^{\circ}\text{C}$

* for prototype samples, special instructions are valid, see §3.2

2. Electrical parameters

2.1 Thermal path and heat sink

A typical thermal energy harvesting application contains a hot side surface and a heat sink (HS) in ambient air as cold side. In between the TGP generator is "sandwiched" and a heat energy (Q) is floating.

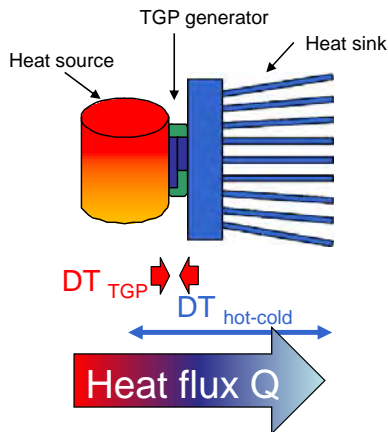

Typical energy harvesting application

The output power of a thermogenerator depends on the amount of heat energy floating through the device. This is represented by the temperature difference directly over the thermogenerator, which depends on its thermal resistance. This can be described by a thermal resistor network (equivalent to Ohm's law for voltage, current and electrical resistance).

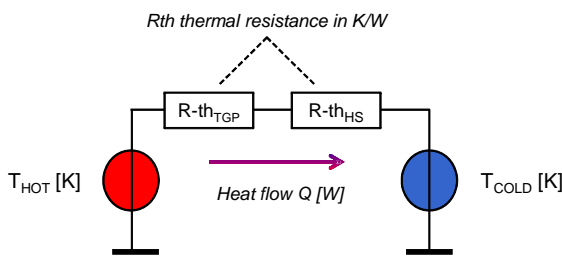

Network diagram for thermal system

The effective (net) temperature difference (Delta-T) over the TGP is determined by:

- Gross Delta-T = $T_{HOT} - T_{COLD}$
- Thermal resistance TGP: $R-th_{TGP}$
- Thermal resistance heat sink: $R-th_{HS}$

The net Delta-T (DT) over the TGP can be analyzed as:

$$\Delta T_{TGP} = \frac{T_{HOT} - T_{COLD}}{R_{th_{TGP}} + R_{th_{HS}}} * R_{th_{TGP}}$$

The larger the heat sink, the smaller the $R-th_{HS}$ and therefore the more heat energy (Q) is floating through the TGP, resulting in a larger, net delta-T over the TGP.

Clear and brief:

- a larger heat sink result in more output power for the TGP

The TGP-751 has a larger active area, than the TGP-651, hence TGP-751 is better suited for applications, that require:

- maximum output power
- Operation from very small temperature gradients

Operation optimum of a thermal system is when:

- $R-th_{TGP} = R-th_{HS}$

Therefore the higher output power capabilities of the TGP-751 can be measured when using a larger heat sink.

Performance results are given in 2.2 and 2.3:

- 2.2: TGP component level, independent from a thermal solution. This is important for thermal systems that don't interface to ambient air, like an application where the TGP is mounted between two pipes carrying hot and cold fluids.
- 2.3: TGP in practical application with a hot source and different practical heat sinks in **ambient air at a temperature of 25 °C.**

2.2 Electrical parameters of TGP components

The matched output power and open circuit output voltage of the TGP depend on the temperature gradient across the device.

To achieve well defined test conditions, both the hot and cold side of the TGP component are held at defined temperatures.

The characterization measurements of the TGP is based on a fixed temperature gradient across the device.

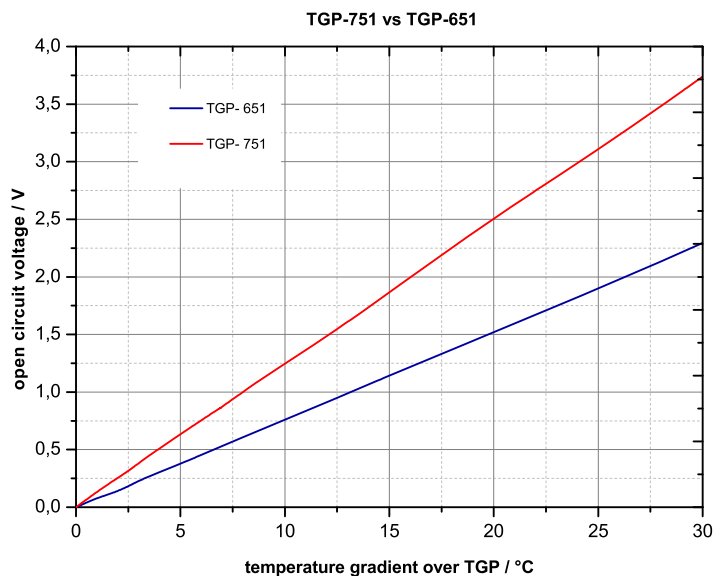
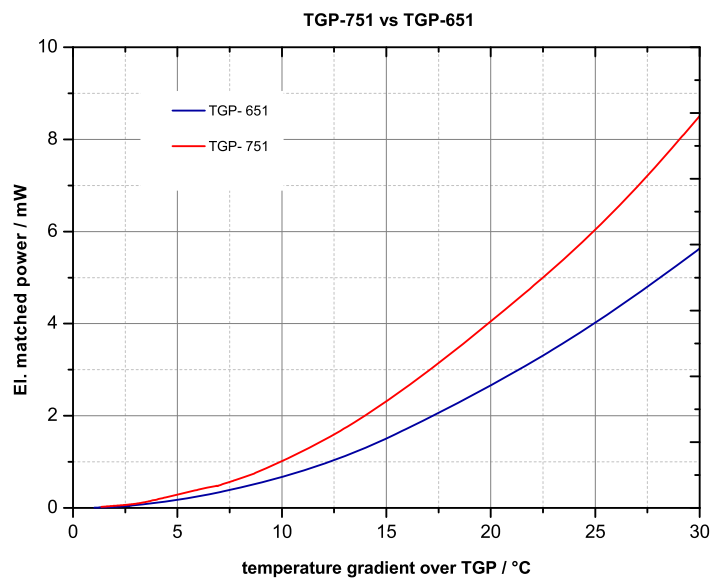

TGP-751 / TGP-651

ThermoGenerator-Package

2.3 Output power performance application

The matched output power depends on the characteristics of the thermal path from heat source to ambient (cold side). The heatsink type, dimensions and position are of influence.

The TGP measurements are made with the **TE-CORE7 ThermoHarvesting Power module, using different heat sinks from Fischer Elektronik, type Sk422 with a length of 33 mm, 50 mm and 90 mm.**

www.fischerelektronik.de

For direct link to heatsink page use link below
<http://tinyurl.com/cw9aun6>

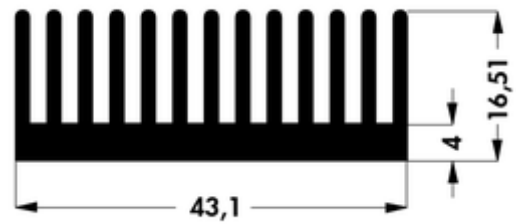

Dimensions Sk422 heat sink

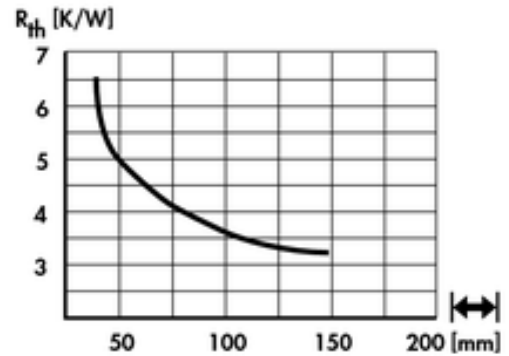

Performance diagram of Sk422 heat sink

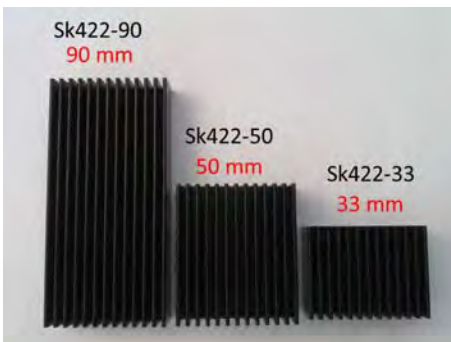

Different heat sink types of Sk422



TE-CORE with heat sink Sk422-33

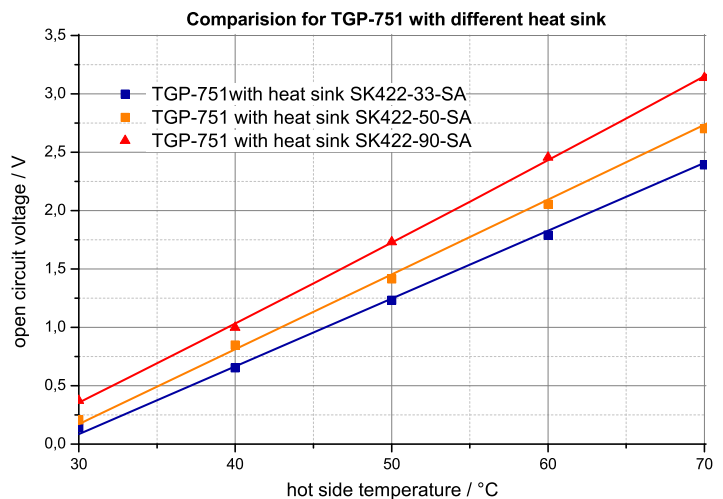
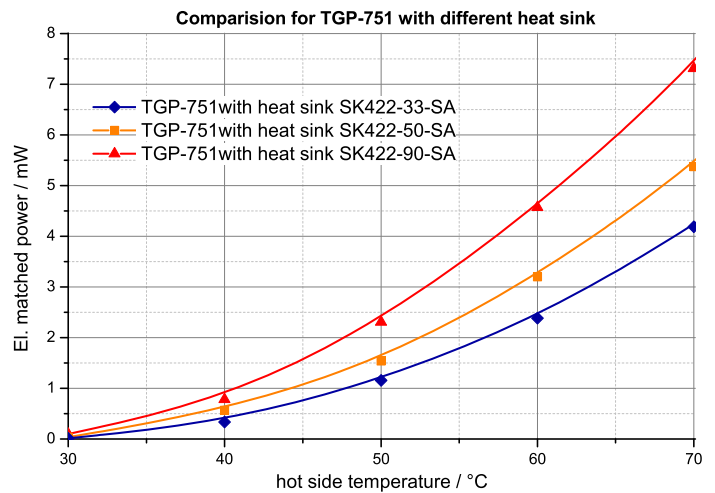

TGP-651 performance measured with TE-CORE6 ThermoHarvesting Power module, using different heat sinks from Fischer Elektronik, type Sk422 with a length of 33 mm, 50 mm and 90 mm.



Summary output power performance:

The output power performance depends on the heat sink (HS) performance in combination with the selected TGP ThermoGenerator Package. The table below describes the relative output power versus the smallest heat sink (33 mm).

	Small HS (Sk-422 33)	Midsize HS (Sk-422 50)	Larger HS (Sk-422 90)
TGP-651	100%	125%	135%
TGP-751	100%	130%	185%

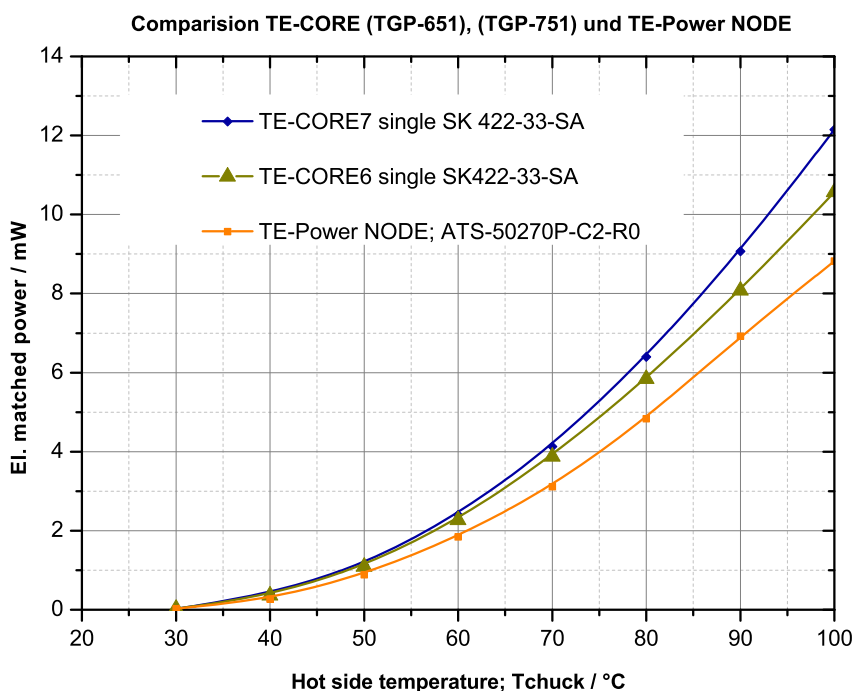
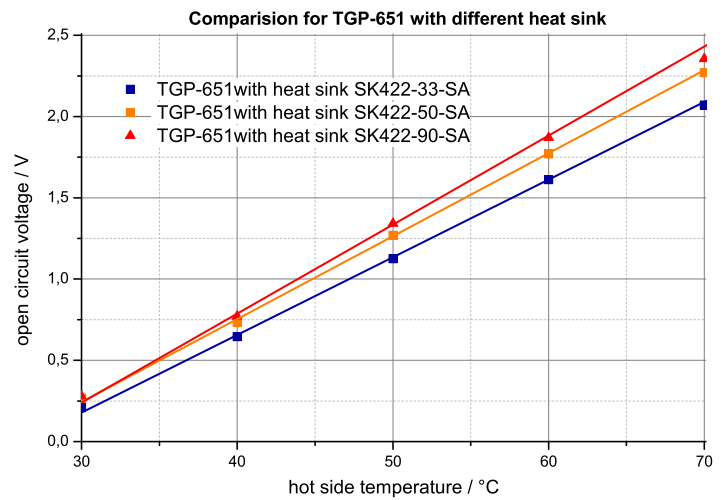
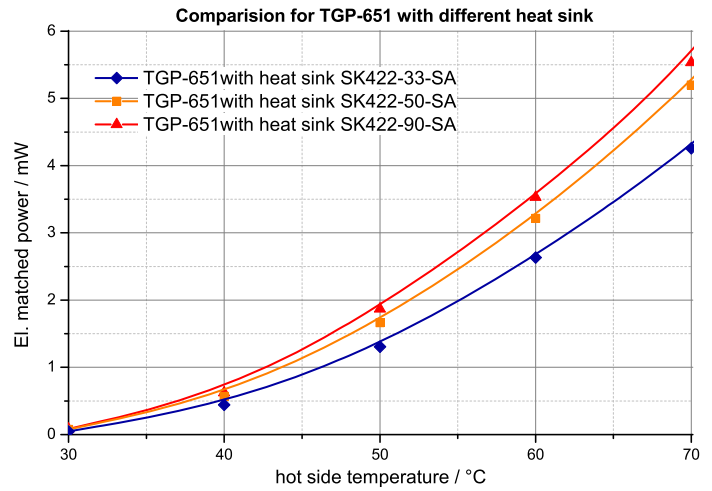

Thanks to the optimized thermal design of the TGP compared to the Micropelt TE-Power NODE evaluation system, the output power of the TGP outperforms the TE-Power NODE.

3. Application information

3.1 Product dimensions

All dimensions are given in millimeters

Drawings are not to scale

Top view

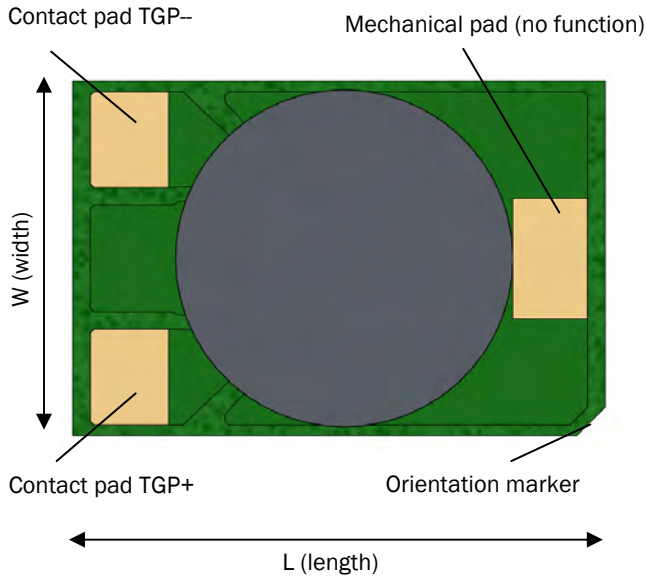

Side View

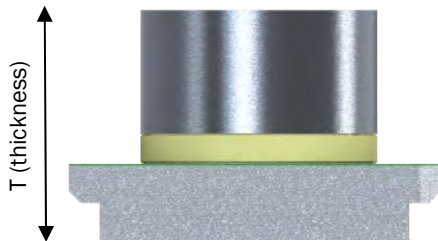

Top View (hot side)

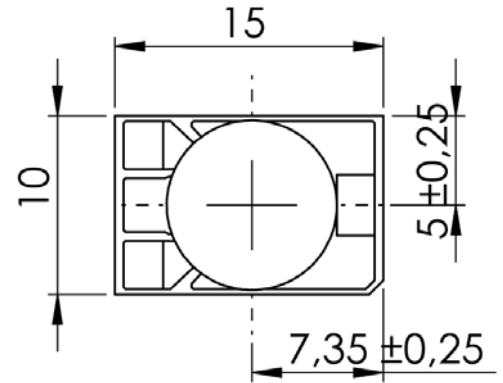

Bottom View (cold side)

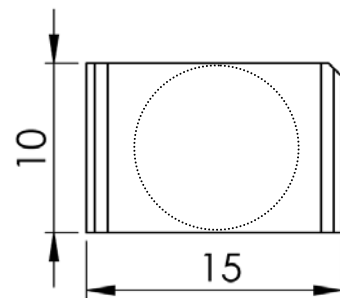

Side View

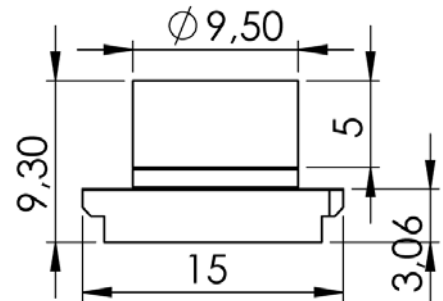

Dimensions TGP

- L = 15.0 mm
- W = 10.0 mm
- T = 9.3 mm

Tolerances according ISO 2768-mK (medium). Except tolerances ± are given in the drawing. (see table §3.1.1)

Solder Pad Layout

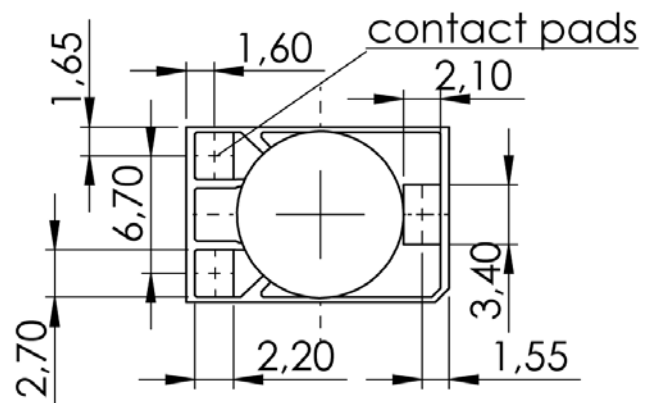

3.1.1 General tolerances for linear and angular dimensions according DIN ISO 2768-mk

For TGP tolerance class „medium“ is applicable, except tolerances ± are given in the drawing.

Permissible deviations in mm for ranges in nominal lengths	Tolerance class designation (description)			v (very coarse)
	f (fine)	m (medium)	c (coarse)	
0.5 up to 3	±0.05	±0.1	±0.2	-
over 3 up to 6	±0.05	±0.1	±0.3	±0.5
over 6 up to 30	±0.1	±0.2	±0.5	±1.0
over 30 up to 120	±0.15	±0.3	±0.8	±1.5
over 120 up to 400	±0.2	±0.5	±1.2	±2.5
over 400 up to 1000	±0.3	±0.8	±2.0	±4.0
over 1000 up to 2000	±0.5	±1.2	±3.0	±6.0
over 2000 up to 4000	-	±2.0	±4.0	±8.0

TGP-751 / TGP-651

ThermoGenerator-Package

3.2 Handling & Solder recommendations

The TGP package can be wired and soldered by using standard solder equipment.

The non-functional connection is being used for mechanical stability. It can also be used to integrate a temperature sensor (e.g. PT100) close to the TGP to monitor the package temperature.

Reflow procedure for mass production will be according IPC/JEDEC.

IMPORTANT NOTE:

- **actual prototypes have to be manually soldered: 270 °C max. and 5 seconds max., to connect wires to the TGP contact pads.**

3.3 Mechanical design

The TGP has to be mounted between a hot and cold source so that:

- There is space for placing electronic components directly next to the TGP, in case of an embedded application with a Printed Circuit Board (PCB)
- Maximum thermal performance can be achieved, by proper distance between a hot and cold source
- No pulling force acts on the three contact pads of the TGP.

A practical example is described for an application with a hot source adaptor (for instance connected to a pipe with hot liquid) and a heat sink in ambient air.

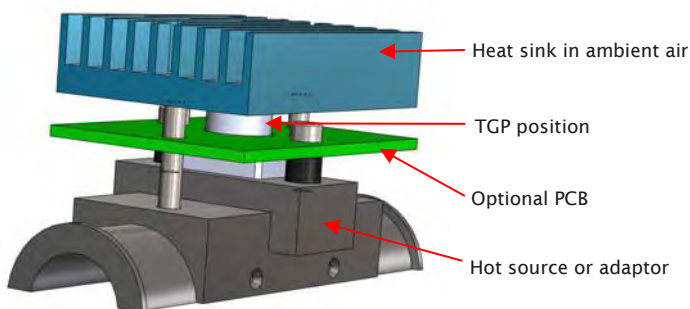

Practical energy harvesting application

A good mechanical connection can be achieved by using a clamp or **stainless steel bolts** to mount the TGP between the hot and cold sources.

Important to observe is:

- Avoid parallel leakage of thermal energy (bypassing the TGP) by using stainless steel bolts, instead of steel bolts. They have a reduced thermal conductivity. Thermal isolator material around the bolts improves mechanical stability.
- When using bolts to clamp the TGP between two metal surfaces, the target force is 35 cNm. Bolts should be fastened in an alternating manner in small steps.
- Thermal paste can be added between the TGP and both the hot and cold sources. Alternatively Graphite foil can be used to achieve good long-term thermal performance (i.e. eGraph type Hitherm 2505, 127µm.)

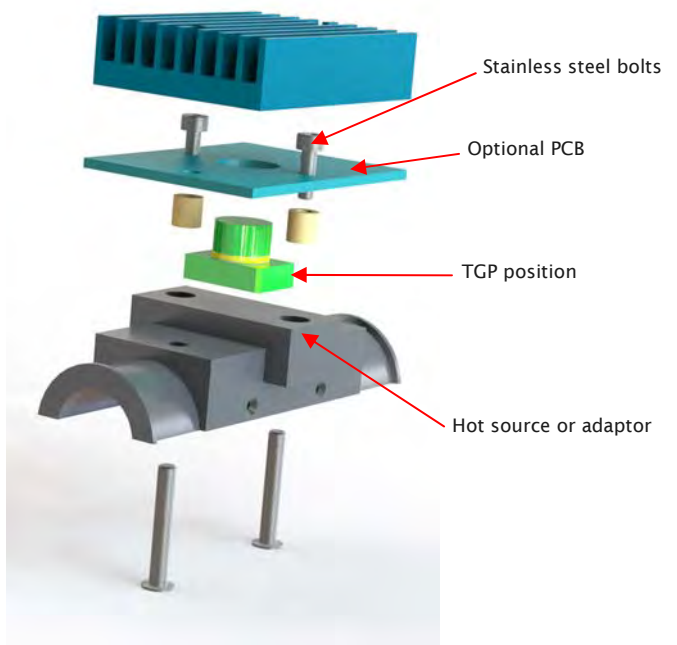

Assembly of TGP

3.4 Reliability Testing

The TGP components are planned to be tested

- Lifetime
- Humidity
- Vibration
- Mechanical shock
- Non-operating thermal shock

IMPORTANT NOTE:

- **actual prototype withstand a mechanical shear force of 15 kg in combination with the manual solder procedure as mentioned in §3.2**

3.5 Environmental compliance

Micropelt ThermoGenerator-in-package components are compliant to the Restriction of Hazardous Substances Directive of RoHS.

3.6 Ordering information

- TGP-751
- TGP-651

4. List of Document Changes

- Ver. 1.7 (2011-09.21)** First published version of TGP datasheet
- Ver. 2.0 (2012-04.04)** considerable revision of the document, optical improvements
page 4, Absolute max. ratings; page 7, link Fischer Elektronik;
page 13 overview of thermoharvesting modules and sensors
- Ver. 2.1 (2012-11.20)** improvements in following chapters
page 5, 2.1 Thermal path and heat sink
page 6, 2.2 Electrical parameters
page 8, 2.3 Output power performance application
page 11, 3.3 Mechanical design

TGP-751 / TGP-651

ThermoGenerator-Package

TE-CORE DC power module



TE-CORE thermoharvesting power module with integrated TGP offers an efficient DC-booster and power management concept.

TE-CORE/RF wireless sensor evaluation kit



TE-CORE /RF is a complete thermo-powered, self-sufficient wireless sensor node system.

It offers an efficient DC-booster and power management concept with prequalified 802.15.4 compatible radio module 2.4 GHz ISM band and evaluation PC software TE-Power SCOPE.



TE-Power PROBE



TE-Power PROBE is an integrated thermoharvester which we specifically designed for operating conditions using natural convection to ambient air.

A powerful heat sink ensures a high level of heat dissipation which leads to maximal thermoharvesting results when mounted in horizontal orientation.

TE-qNODE



TE-qNODE is a battery-free wireless sensor for thermal monitoring of electrical distribution systems, i.e. bus-bars and busways.

Resistive heat is used to power continuous monitoring for increased safety and power availability in 24/7 production environments.

4. Important Notices – Please read carefully prior to use

1. Micropelt Products are prototypes

Micropelt supplies *thermoelectric* coolers and *thermogenerators in package*, as well as *energy harvesting modules* (hereinafter referred to as “Prototype Products”). The Prototype Products distributed by Micropelt to date are prototypes that have not yet been released to manufacturing and marketing for regular use by end-users. The Prototype Products are still being optimized and continuously tested. As such, the Prototype Products may not fully comply with design-, marketing-, and/or manufacturing-related protective considerations, including product safety and environmental measures typically found in end products that incorporate such semiconductor components or circuit boards. In addition, the Products have not yet been fully tested for compliance with the limits of computing devices, neither pursuant to part 15 of FCC rules nor pursuant to any other national or international standards, which are designed to provide reasonable protection against radio frequency interference.

2. Use of Products restricted to demonstration, testing and evaluation

Micropelt’s Prototype Products are intended exclusively for the use for demonstration, testing and evaluation purposes. The Prototype Products must not be used productively. In particular, the Prototype Products must not be used in any safety-critical applications, such as (but not limited to) life support systems, near explosion endangered sites, and/or any other performance critical systems. The Prototype Products must only be handled by professionals in the field of electronics and engineering who are experienced in observing good engineering standards and practices.

3. Warnings and use instructions

- Using Micropelt’s Prototype Products without care and in the wrong context is potentially dangerous and could result in injury or damage. The Prototype Products are designed for use within closed rooms in conditions as apply for electronics such as computers; except when indicated expressively. Keep the Prototype Products away from open fire, water, chemicals, gases, explosives as well as from temperature conditions above 100 degrees centigrade, or as indicated in the datasheet of the product. When testing temperature settings at the limits given in the datasheet for longer term, do not leave the Prototype Products alone but monitor their performance. Take special care to monitor closely whenever the Prototype Products are connected to other electrical items and/or electronics.
- If the Prototype Products use wireless data transmission technology, therefore they receive and radiate radio frequency energy. They have not yet been fully tested for compliance with the limits of computing devices, neither pursuant to part 15 of FCC rules nor pursuant to any other national or international standards, which are designed to provide reasonable protection against radio frequency interference. Operation of the Prototype Products may cause interference with radio communications, in which case the user at his own expense will be required to take whatever measures may be necessary to correct this interference and prevent potential damage. Do take special care not to operate the Prototype Products near safety-critical applications or any other applications known to be affected by radio frequencies.
- If any of the Prototype Products elements are separated from the complete module and used independently, it is important to control each individual system’s power supply to be within their acceptable voltage and/or amperage range. Exceeding the specified supply voltage and/or amperage range may cause unintended behavior and/or irreversible damage to the Prototype Products and/or connected applications. Please consult the Prototype Products’ User Guide prior to connecting any load to the Prototype Products’ output. Applying loads outside of the specified output range may result in unintended behavior and/or permanent damage to the Prototype Products. If there is uncertainty as to the supply or load specification, please contact a Micropelt engineer.
- During normal operation, some circuit components may have case temperatures greater than 70°C. The Prototype Products are designed to operate properly with certain components above 70°C as long as the input and output ranges are maintained. These components include but are not limited to linear regulators, switching transistors, pass transistors, and current sense resistors. These types of devices can be identified using the evaluation unit schematic located in the dataheet. When placing measurement probes near these devices during operation, please be aware that these devices may be as hot as to inflict the risk of burning skin when touched.
- Due to the open construction of the Prototype Products, it is the user’s responsibility to take any and all appropriate precautions with regard to electrostatic discharge and any other prevention measures for safety.

4. User’s Feedback

Micropelt welcomes the user’s feedback on the results of any tests and evaluations of the Prototype Products. In particular, we appreciate experience information on use cases with indications of strengths and weaknesses of the Prototype Products, its robustness in operation and its long-term durability. Please, contact our Micropelt Application Engineering colleagues by email at engineering@micropelt.com.

Prototype Products, its robustness in operation and its long-term durability. Please, contact our Micropelt Application Engineering colleagues by email at engineering@micropelt.com.

Micropelt GmbH | Emmy-Noether-Str. 2 | 79110 Freiburg (Germany)