

# COMROD AMX85

## Portable 8.5 m Sectional Antenna Mast

### Application:

AMX85 is a portable, lightweight, dielectric antenna mast system consisting of 7 tubular fiber glass sections. The AMX85 is designed for support of one or two broadband VHF antennas (Not included)(COMROD VHF3088VM). AMX85 could however, also be used for a number of other applications, for instance as support for broadband HF dipole or other antenna systems.

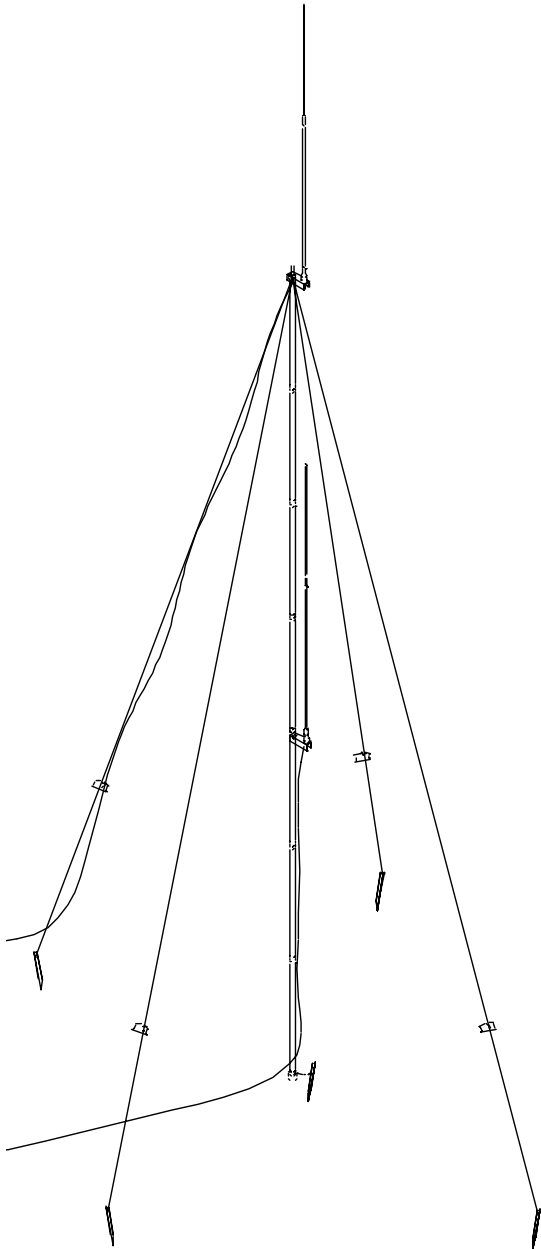

### Specifications:

Mast sections:	Fibreglass tube 43/38, 122 cm long with 10 cm aluminium spigot. Olive drab lacquer finish. 7 pcs.
Guys:	4 pcs, 3mm braided line on winder with adjustable lock and snap hooks each end.
Guy pegs:	6 pcs hot galvanized steel.
Base support:	Fibreglass with spikes.
Top load:	Max. 4.0 kg
Moment of flexure:	Max 60 kpm
Temperature range:	-55 °C, +55 °C; -67 °F, +131 °F

The mast design and accessories may be adjusted to various climatic and environmental conditions and special applications. The mast system can be clamped to a vehicle and thus be used without guy support.

### Weight and measures:

Length, erected:	8.5 m	
Total, weight standard version:	1135x22x15 cm	16.2kg
Mast sections:	7 sections	1.0 kg
Guy rope with winder:	4 pcs.	0.2 kg
Guy pegs:	6 pcs.	0.3 kg
Base support:	1 pc.	0.2 kg
Hammer:	1 pc.	1.2 kg
Carrying bag:	1 pc.	2.2 kg
RG58 cable on winder	2 pcs. 20 m	1.0 kg
Bracket	2 pcs.	0.5 kg

Nato codification complete mast

5985-25-136-9199

## Parts:

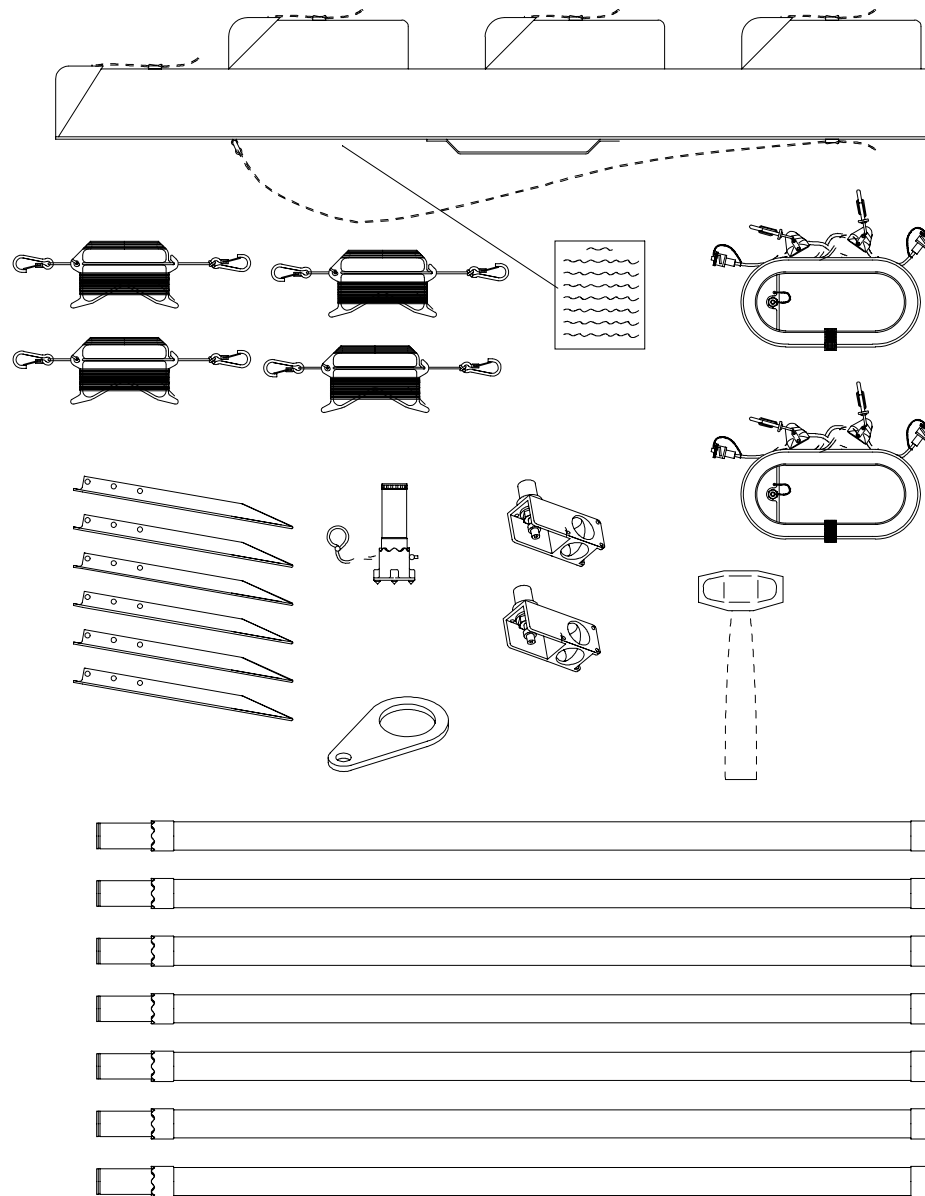

The sections may be used at random and the mast could be used even with one section missing. The design is very robust and resistant to icy and muddy conditions.

Fibreglass reinforced plastics are electrically insulating. This reduces the hazard of electrical shocks when erecting the antenna mast in an area with overhead power lines.

The mast has no influence on radiation characteristics of the antennas.