

# COMROD AC15-BI

## Marine multiband cellular antenna

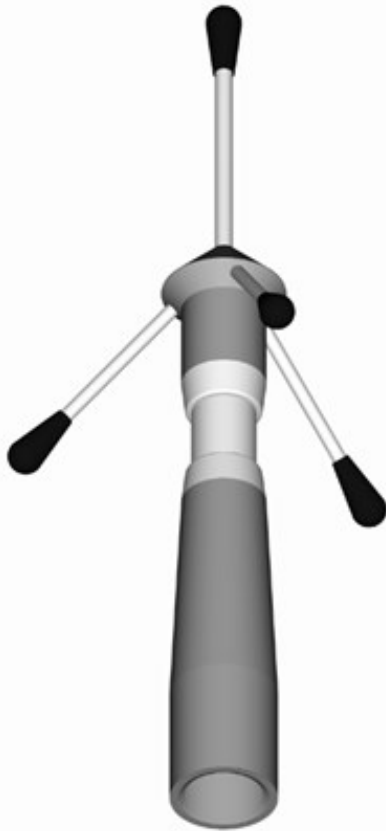

### Application:

The AC15-BI is a high quality antenna designed for nearly all US and European cellular frequencies including GSM. It's rugged design means it can be installed on all kinds of vessels, from ocean liners to pleasure crafts.

The good gain means it will give significantly better transmission quality than the mobile phone's standard antenna.

It does not require a ground plane.  
 It comes with integrated BNC coaxial connector.

### Electrical specifications:

Frequency range	825-895 MHz 880-960 MHz 1710-2170 MHz
Nominal impedance	50 ohm
Power rating	25 W
Gain	2 dB
Pattern	Horizontal plane: Omnidirectional
Polarization	Vertical
Connector	BNC female

### Mechanical specifications:

Design	Multiband ground plane antenna
Height	10" (250mm.)
Weight	0.5 kg
Wind rating	55 m/s = 125 mph
Finish	Polyurethane lacquer, white Stainless steel
Temperature range	-55 °C, +80 °C; -67 °F, +131 °F

### Mounting:

The AC15-BI is fitted with UNS1"x14 female ferrules.

Can be used with all standard mounting accessories.

Integrated BNC female coaxial connector.

All the BI versions come with a tool to mount the BNC male coaxial connector inside the stainless steel ferrule.

AV-C adapter: To be able to make all 4ft. And 8ft. -BI version antennas – to a side feed cable version (to compensate for all C-version) - AV-C adapter is required. Also available as P version.

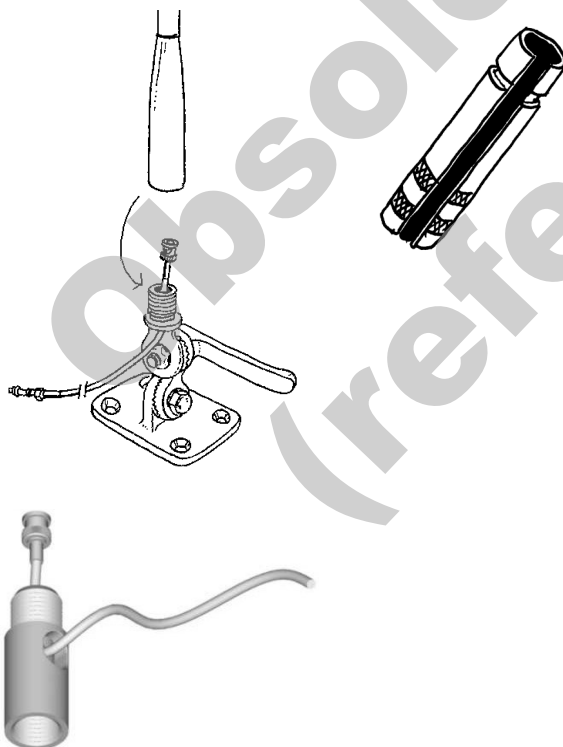

4-way bracket and coaxial cable not included - UNS: Unifield Special

**Supplement: (optional extra)**

**RG58 Cable.**

Available  
in:  
40ft 12m.  
23ft 7m.  
16ft 5m.  
2ft 0,6m.

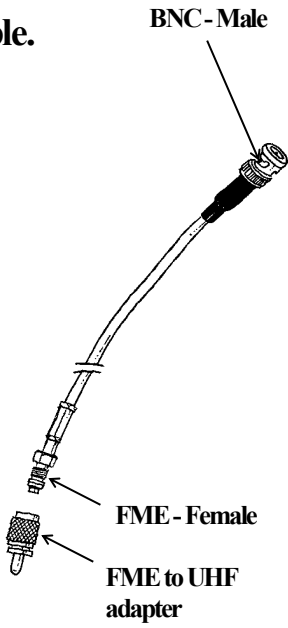

**4 way bracket.**

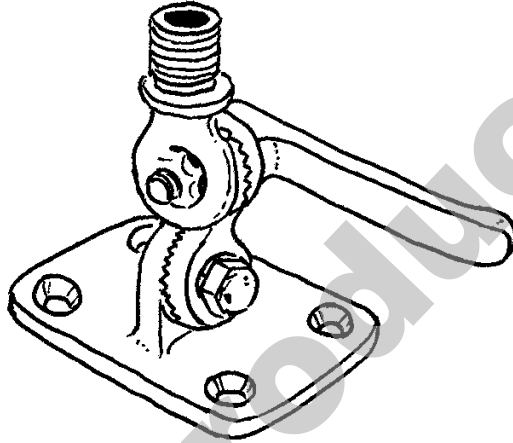

**Extension  
Masts.**



Obsolete Product  
(reference only)