



15 meter (50 ft) ULM-C 48/15-1.3 mast
(shown supporting Comrod Band 4 dish antenna)

Overview

- The ULM-C 48 is an ultra-lightweight carbon composite tripod mast capable of supporting headloads up to 20 kg (44 lbs) *
- Fully deployed height of 15 meters (50 ft).
- The mast is comprised of individual carbon composite mast tube sections that fit together to give the desired height.
- The aluminum tripod support includes a lifting mechanism and hoist to raise each section.
- Telescopic tripod legs allow deployment on uneven ground.
- Tripod height of 1.4 meters (55 in) allows easy access to top load
- Central guying enables the guy tension to be maintained during deployment of the mast. Enables safe deployment high winds.
- Supplied with a ground mounting kit containing all the items required for field deployment.
- Optional antenna mounting kit can be supplied to allow an omni-directional antenna to be mounted below the top load (see page 4)
- Can be used to elevate omni-directional & directional antennas, sensors, lighting, etc. *
- Can be deployed by two operators in 20 minutes.
- Full compliance with ANSI TIA/EIA-222-F wind standard.

*Maximum headload subject to weight and wind surface area



Complete mast kit packs into two man-portable bags

Mechanical Specifications

Maximum height	15 m (50 ft)
Tube diameter	48 mm (1.89 ins)
Mast section length	1300 mm (51 ins)
Maximum Headload *	20 kg (44 lbs)
Maximum wind speed:	
Deployment	40km/h (25 mph)
Operation	90km/h (56 mph)
Survival	120km/h (93 mph)
Total kit weight	45 kg (99 lbs)
Guy Radius	15 m (50 ft)
Top load interface	Ø41.8 mm (Ø1.65 ins) spigot
Temperature range	-40°C (-40 °F) to +55°C (131 °F)
Anchoring	3 locations at 120°
Guying - 2 levels	Lower level - Kevlar/Polyester Rope Upper level - Kevlar/Polyester Rope
Standard color	Black
Number of operators	2
Set-up time	20 mins



Tripod assembly with mast section hoist and lifting mechanism

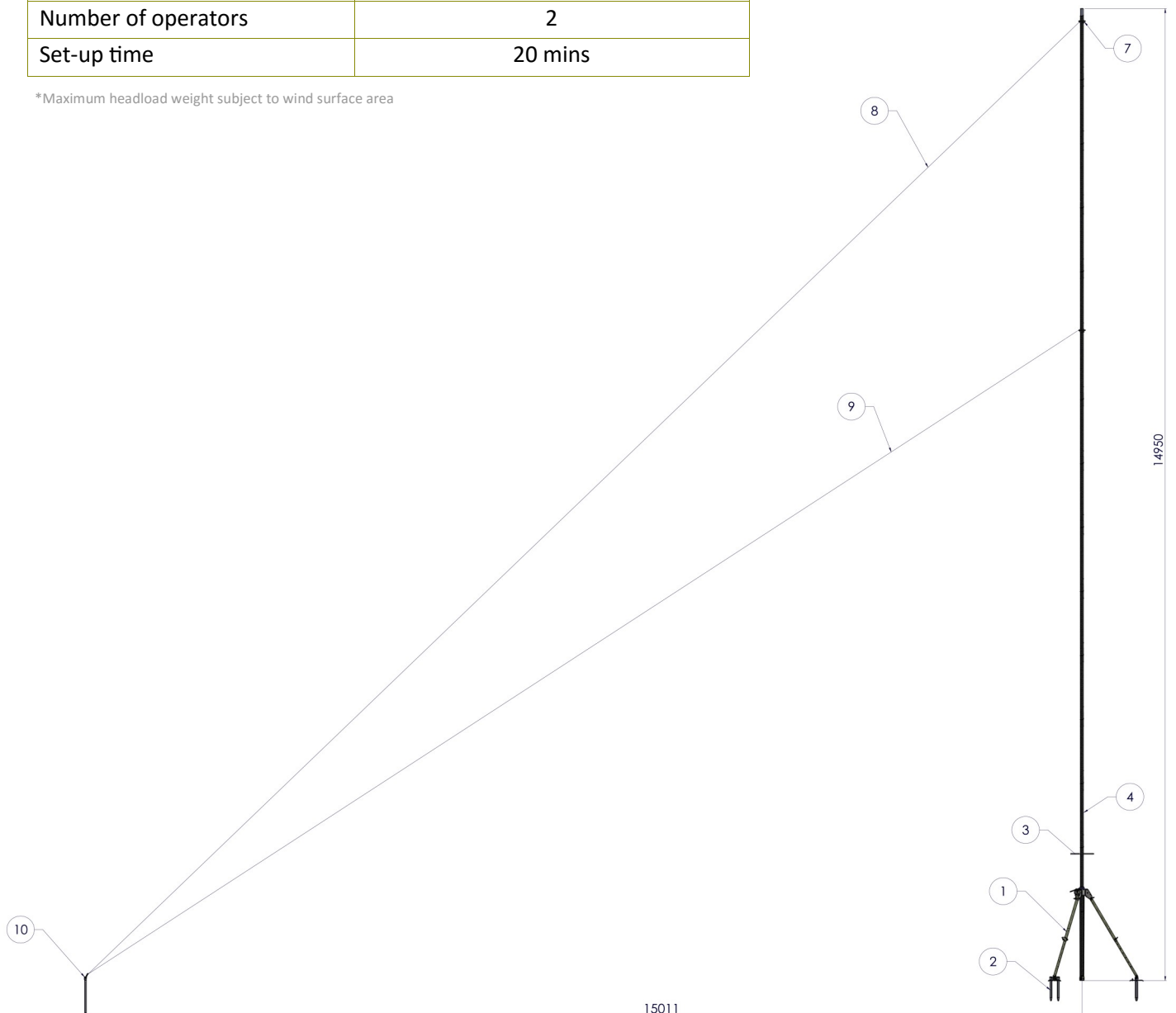

*Maximum headload weight subject to wind surface area

Standard Kit List



Bag 1



Bag 2

Description (Bag 1)	Item	Qty
Mast section (Carbon Fiber Composite)	4	15
Transportation bag	-	1

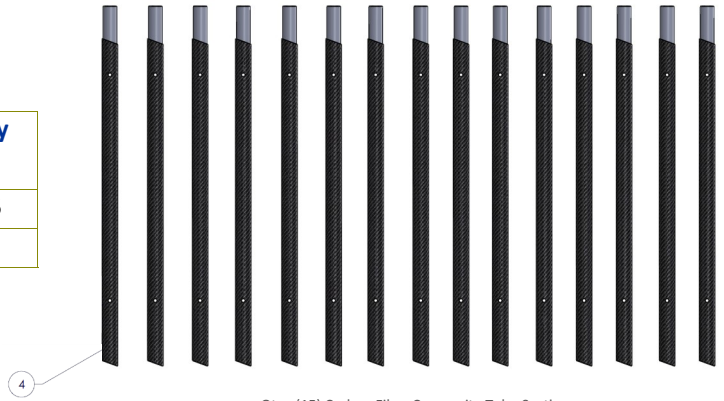

Qty : (15) Carbon Fiber Composite Tube Sections

Description (Bag 2)	Item	Qty
Tripod assembly with lifting system	1	1
Anchor stakes	2	6
Cross pin	3	2
Guying collar	7	2
Upper guy cable	8	3
Lower guy cable	9	3
Guy stakes	10	3
Guide handle	11	1
Fast Tensioner	12	3
Radius rope	13	1
Lifting handle	14	1
Hammer 3 kg	15	1
Transportation bag	-	1



Qty : (1) Tripod Assembly

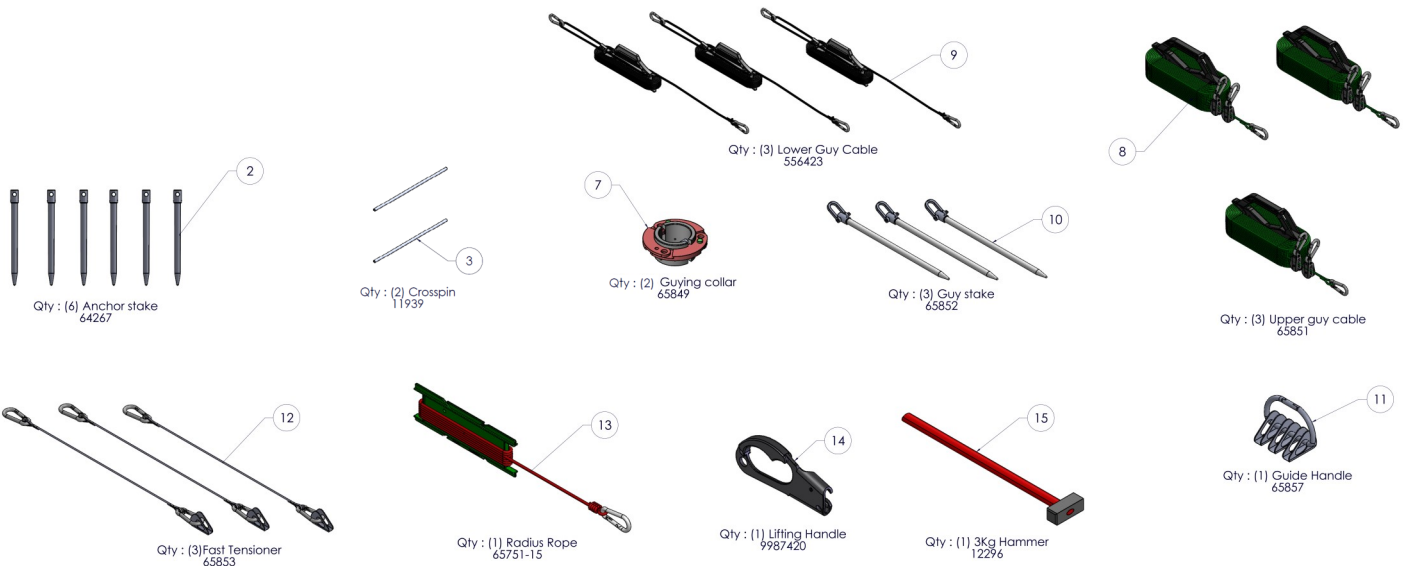

Options

Omni-directional antenna mounting kit (below top load)

The ULM 48 mast can be supplied with an optional mounting kit that enables an omni-directional antenna to be mounted below the top load. The kit includes an antenna mounting bracket together with two glass fiber tube sections. Glass fiber sections are RF invisible so will have no effect on the performance of the lower antenna. These two sections replace the carbon composite sections in the area directly next to the antenna radiating element. The image below shows two Comrod elevated tri-band antennas, one mounted at the top of the mast, the other positioned beside the glass fiber sections.

Description	Item	Qty
Mast section (Glass Fiber Composite)	1	2
Bracket	2	1
Transportation bag	-	1

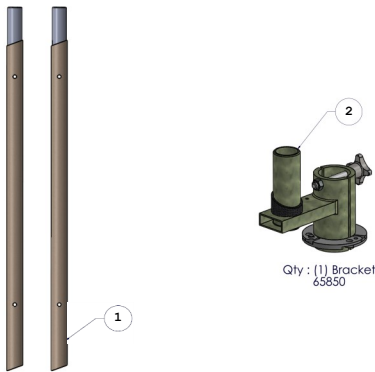

15 meter ULM-C 48/15-1.3 mast supporting
Two Comrod VHF302000TB-TRI/TB-S elevated
tri-band antennas



13 carbon fiber and 2 x glass fiber tube sections
(2 x glass fiber sections will be painted black to
match standard carbon sections)