

COMROD AC15-P

Marine multiband cellular antenna



Application:

The AC15-P is a high quality antenna designed for nearly all US and European cellular frequencies including GSM. It's rugged design means it can be installed on all kinds of vessels, from ocean liners to pleasure crafts.

The good gain means it will give significantly better transmission quality than the mobile phone's standard antenna.

It does not require a ground plane.

It comes with integrated N coaxial connector.

Electrical specifications:

Frequency range	825-895 MHz 880-960 MHz 1710-2170 MHz
Nominal impedance	50 ohm
Power rating	25 W
Gain	2 dB
Pattern	Horizontal plane: Omnidirectional
Polarization	Vertical
Connector	N female

Mechanical specifications:

Design	Multiband ground plane antenna
Height	10" (250mm)
Weight	0.6 kg
Wind rating	55 m/s = 125 mph
Finish	Polyurethane lacquer, white Stainless steel
Temperature range	-55 °C, +80 °C; -67 °F, +131 °F

Mounting:

The AC15-P is fitted with UNS1"x14 male ferrules and BSP1" x 11 nut.

Adapter for UNS1"x14 female ferrules is available (see reverse page).

Can be used with all standard mounting accessories.

Integrated N female coaxial connector.

Suitable cable: RG58, RG213 or similar.

BSP : British Standard Pipe

UNS: Unifield Special

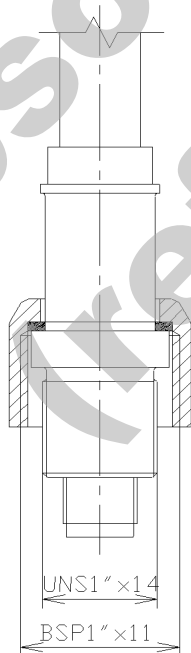

Supplement: (optional extra)

Adapter for 4 way bracket

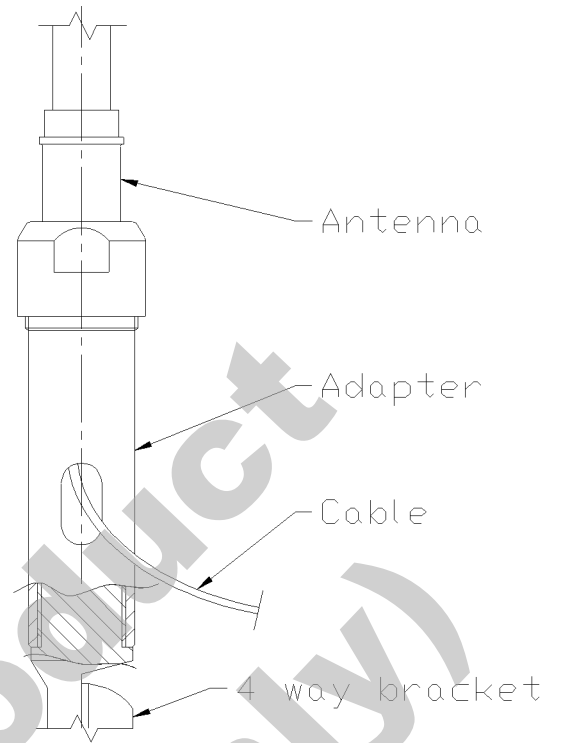
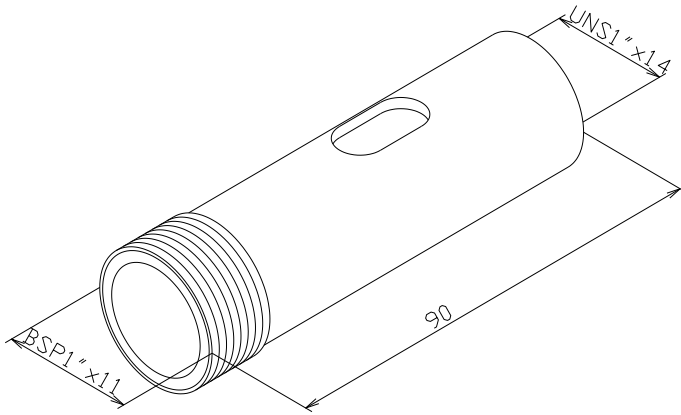

Straight-Mount Bracket

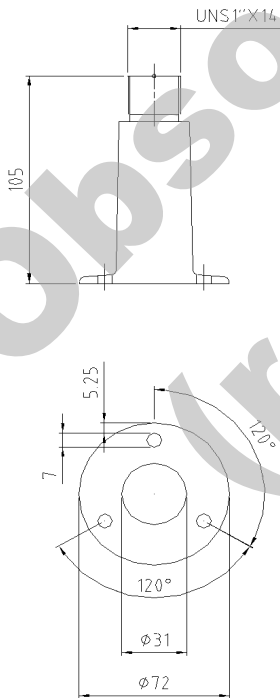

4 way bracket.

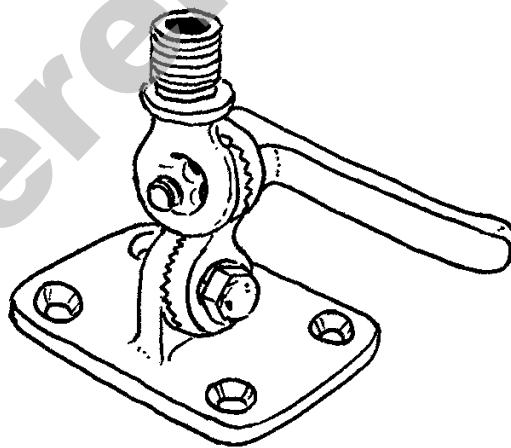

Extension Masts.

