

COMROD UHF2450VM-8

High Gain WLAN Antenna

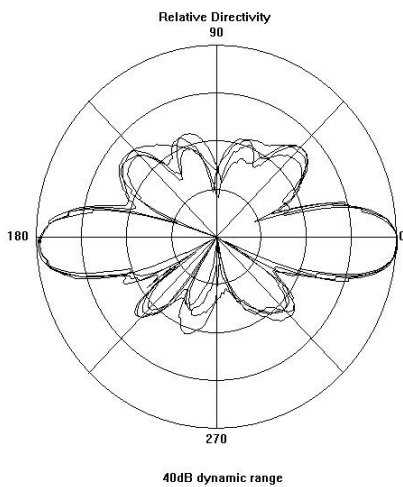

Radiation pattern for 2400, 2420, 2460 and 2480MHz

Application:

- * High gain antenna for the Wireless LAN
- * 2400-2500 MHz, IEEE 802.11g
- * Designed for operation on all kinds of vehicles including Jeeps, Trucks and other armoured vehicles.
- * Suitable for operation on shelters and to be mounted on masts or in other permanent installations.
- * Different kinds of bases available, with or without spring for flexible or rigid installations.
- * No ground plane needed.

Electrical specifications:

Frequency range	2400-2500 MHz
VSWR	<2
Nominal impedance	50 ohm
Power rating	5 W CW
Gain	8dBi
Radiation pattern	Azimuth: Omnidirectional Elevation: See diagram below
Polarization	Vertical
Connector	N female

Mechanical specifications:

Design	Phased $\lambda/2$ elements in a collinear array . Radiating element completely enclosed in epoxy/fiberglass laminate. Metal parts are brass and stainless steel.
Length	0.8m, with spring base
Weight	0.8 kg, ex. base
Wind rating	55 m/s = 125 mph
Finish	Polyurethane lacquer, olive drab.
Temperature range	-55 °C, +71°C; -67 °F, +160 °F