

# CX93610 DIFT JPEG Encoder

## SmartVideo Product Brief



# Low-Power HD Camera Encoder for Wireless and Battery-Operated Cameras

## Product Overview

The CX93610 is a monolithic mixed signal ASSP designed for low cost and low power motion detection surveillance camera applications, as well as home monitoring/remote monitoring applications. Used with an external CMOS image sensor, the CX93610 offers a variety of specialized JPEG encoding techniques to highly compress and save image data in an internal 512KB/256KB frame buffer. An optional 2:1 and 4:1 scaler is available for image re-sizing. In addition, a 4:2:0 sub-sampling conversion is available to further reduce image file sizes. With a microphone input and programmable allocated buffering, a 2-bit or 4-bit ADPCM audio session can be recorded simultaneously during image captures. The stored images and audio data are then passed on to an external microprocessor for uploading to a preferred medium.



The CX93610 is controlled through a simple register set through the microprocessor interface, and the variety of available interfaces (SPI, UART, and I<sup>2</sup>C) allow for wide flexibility in microprocessor selection. With both digital and analog photocell sensor inputs available, the CX93610 can facilitate the measurement of ambient light and use an on-chip LED driver to control an external infrared LED array during low-light conditions. With low cost, low power, and high image compression capability, the CX93610 is ideally suited for security and monitoring applications.

## Applications

- PIR sensor with video
- Video intercom/door phone
- Baby monitor applications
- Remote home monitoring
- Low-end surveillance camera

## Key Features

- Integrated mixed-signal design for analog-to-digital image processing
- On-chip 512KB/256KB frame buffer
- Supports enhanced JPEG compression techniques and >1MP CMOS sensors, and processes both color and black and white images
- DIFT-encoded JPEG reduces file sizes by up to 99%
- Low sleep mode power –10nA, and low operating power (<15mA)
- Frame-by-frame motion detection with programmable thresholds
- Integrated analog components (ADCs, LCD driver)
- I<sup>2</sup>C, SPI, and UART interfaces for flexible connectivity
- Register-driven device
- Optional microphone input records audio session simultaneously during image captures
- Visual verification of intruder through an image sensor interface
- Privacy mode—Blurs out image details
- Frame-by-frame motion detection with programmable thresholds

## System Block Diagram

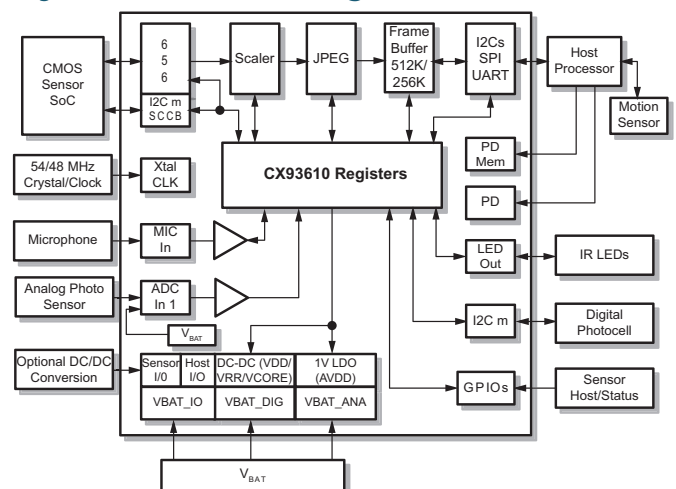

## Additional Features

### Operating Modes

- SXGA 1.3MP (1280x1024) and HD (1280x720)—Black and white or color up to 15fps (512KB option only)
- D1 (720x480) and VGA (640x480)—Black and white or color up to 30fps
- Up to 5MP (2592x1944)—Black and white or color, JPEG still captures (512KB option only)
- Resolution scaling of ½ or ¼ (available for input resolutions of 1280x1024 or lower)
- 4:2:2 to 4:2:0 sub-sampling conversion (available for input resolutions of 1280x1024 or lower)
- JPEG and MJPEG image compression (ISO/IEC 10918-1/2)
- Programmable difference threshold encoded JPEG mode (DIFT)
- Differential-encoded JPEG mode (DIFF)
- Programmable DCT tables for ultimate flexibility in compression and image quality (two pre-defined tables)
- Light detection through luminance measurements with auto IR LED control
- Continuous streaming and variable image modes
- 512KB/256KB frame buffer for compressed images (no external memory) with programmable audio buffer allocation

- Interface to external mP through SPI, UART, or I<sup>2</sup>C
- Variable IR illumination control port
- A/D for photocell sensor, battery voltage monitor, and microphone inputs
- Sleep mode—SoC off, except the frame buffer in retention mode
- Integrated DC-DC converter for reduced power consumption

### Interfaces

- Sensor i/f:
  - 8-b 4:2:2 YCbCr with BT-656 embedded timing codes, or frame/line sync support up to 54 MHz, progressive mode
  - Resolutions of 5MP (2592x1944), 1.3MP SXGA (1280x1024), (VGA (640x480), and QVGA (320x240)
  - 54MHz or 48MHz clock output with divide-by-two option for 27MHz or 24MHz output
  - Crystal/clock input allowing 54MHz, 48MHz, 27MHz, or 24MHz. Supports fundamental and third overtone crystals
  - 2/3 wire control i/f—I<sup>2</sup>C master port or SCCB
- Four-wire I<sup>2</sup>C/SPI/UART slave port to external mP
- Eight GPIOs (five dedicated pins and three shared pins)
- IR illumination with variable DAC control

- Microphone input, microphone boost 0dB–36dB in 6dB steps, 2-bit and 4-bit ADPCM
- DC measurement battery monitor
- Photocell sensor input—Analog or I<sup>2</sup>C (shared with the GPIO)
- Support for battery operation—3.6V to 1.8V

### 56-Pin eMLF/QFN

- –40°C to 85°C ambient, 100°C junction
- <15mA in operational mode
- <10nA in sleep mode

## Benefits

- No external components required for image conversion
- No external RAM required
- Provides excellent image processing up to 30fps
- Faster transfer time and longer battery life
- Longer battery life and energy-efficient design generates less heat
- Enhances monitoring by alerting host of activity
- No analog components required
- Allows for wide selection of microprocessors
- Simple operation; no internal CPU
- Provides complete A/V solution with flexible frame buffer for audio and video data storage

[www.conexant.com](http://www.conexant.com)

Headquarters: 1901 Main Street, Suite 300 Irvine, CA,92614

General Information: U.S. and Canada: 888-855-4562 | International: 1 + 949-483-3000

014PBR00