



News Release

CyboEnergy Awarded U.S. Patent for Its Solar Power Mini-Inverters

August 18, 2014 – CyboEnergy, Inc. (Rancho Cordova, CA), announced today that the company has been awarded U.S. patent 8,786,133 entitled “Smart and Scalable Power Inverters.” CyboEnergy has implemented the technology in its award-winning CyboInverter product family for both grid-interactive and off-grid solar power systems. As a unique and patented feature, CyboInverter has multiple input channels, each of which has its own control and maximum power point tracking (MPPT) mechanism so that solar power production is maximized and the partial shading problem is eliminated.

CyboEnergy CEO, Dr. George Cheng said, “We have built our patent portfolio by filing patents in the U.S. and around the world for those inventions that have significant technical advantages and can also generate economic benefits for the customers. For instance, the design of having multiple input channels in this patent makes the solar power system safer and installation easier, solves partial shading problems, maximizes power production, and reduces the amount of electronic components needed thereby cutting cost.”

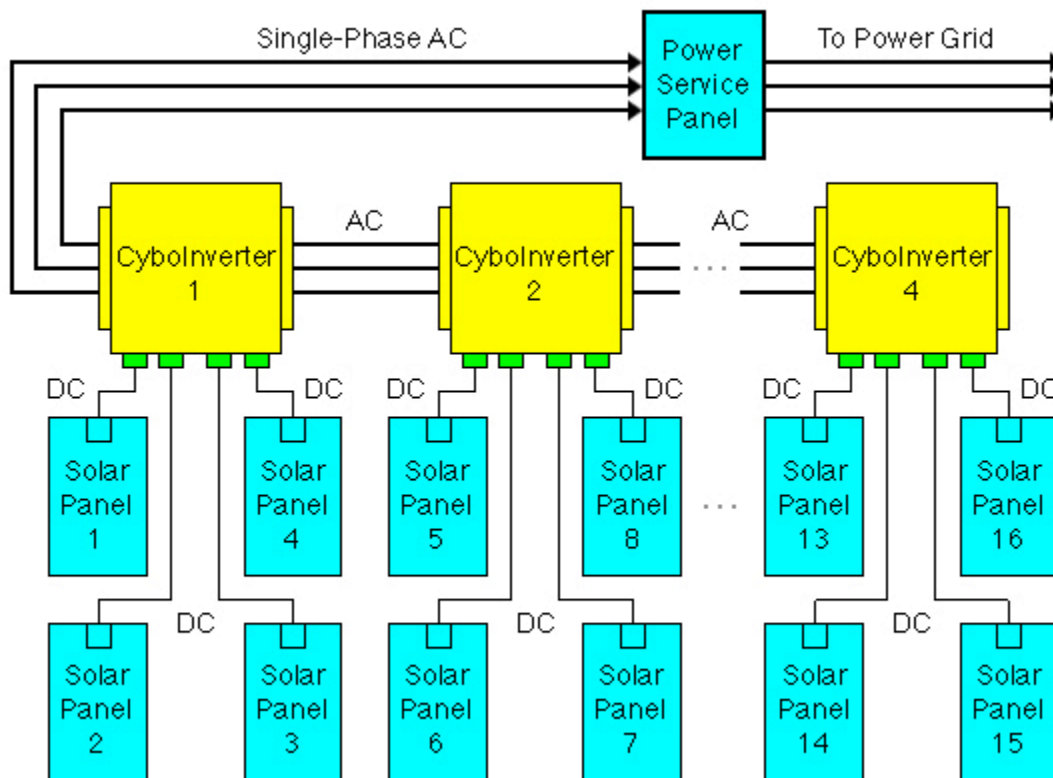



The drawing above demonstrates the essence of the scalability of this invention. In this case example, the smart and scalable power inverters are 4-channel CyboInverters in solar power applications. One can build a small-scale or a very large-scale solar power system with various numbers and sizes of smart and scalable power inverters. Regardless of the number and types of DC sources that each power inverter can handle, the smart power inverters in the same family can daisy chain or connect in parallel producing AC power that is the summation of the AC power supplied by each smart power inverter. This “anything goes” design significantly improves the scalability, flexibility, user-friendliness, and return-on-investment (ROI) of renewable power generation systems including photovoltaic solar power systems. In addition, an existing system can be easily expanded by installing more solar panels and smart power inverters. This makes solar power systems attractive to both homeowners and businesses where only limited budgets are available and continued investments can be made to expand the system over time. This invention can have strategic importance to the renewable energy industry and society.

About CyboEnergy and CyboSoft

CyboEnergy is a subsidiary of CyboSoft, focusing on development, manufacturing, marketing, and services of product lines in the clean energy field. CyboEnergy received the Frost & Sullivan’s 2013 Global Product Differentiation Excellence Award for Solar Inverters. Founded in 1994, CyboSoft is the leader in control technology serving the worldwide process control, building control, and equipment control markets. CyboSoft’s patented Model-Free Adaptive (MFA) control technology for automatically controlling physical processes is a major breakthrough. No other comparable technology possesses all the attributes of MFA.

For more information, please contact: CyboEnergy, Tel: (916) 631-6313, e-mail: Mary Lou Davis, mldavis@cybosoft.com, Web site: www.cyboenergy.com.

Cybo, CyboSoft, and MFA are registered trademarks of CyboSoft, General Cybernation Group, Inc. CyboEnergy and CyboInverter are registered trademarks of CyboEnergy, Inc.