

**TABLE OF CONTENTS**

Applications and Features ..... 1

Shop Pro® Components ..... 2

Set-up and Maintenance ..... 3

⚠ Important Safety Precautions..... 4

Hoses and Adapters ..... 5

Priming the PACCAR MX 11 EPA 2013 & MX 13 EPA 2013 Engine . 6

Priming the PACCAR MX 13 EPA 2010 Engine..... 10

Tank Sweeping With Filtration..... 13

Fuel Transfer with Filtration..... 14

Service Parts..... 15

Service Parts For Priming MX Engines..... 16

Warranty Policy..... 17

Parts Return Policy..... 18

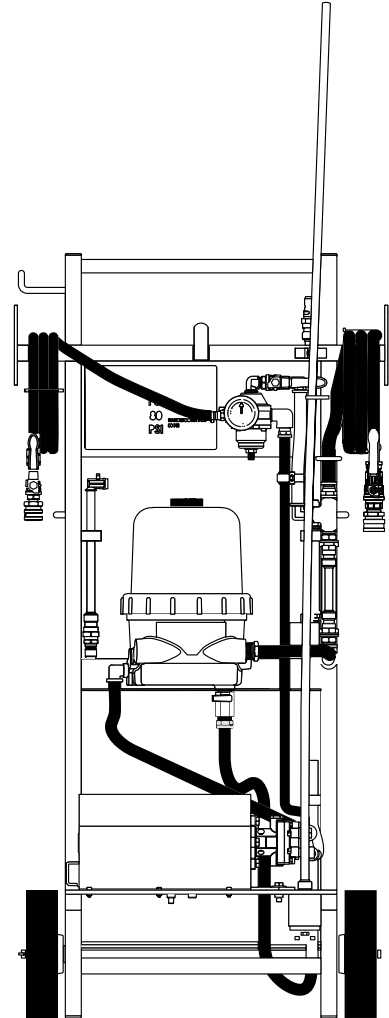

**DAVCO SHOP PRO® FXP**  
**FOR MX ENGINES WITH REGULATOR**  
**TECHNICAL MANUAL**

**FOR ADDITIONAL INFORMATION, VISIT [www.davco.com](http://www.davco.com)**

F1352 REV A



## APPLICATIONS AND FEATURES

- ⚠ **CAUTION!** The Shop Pro is only approved for use with diesel fuel. It is **not** approved for use with gasoline or any other flammable liquids.
- ⚠ **WARNING! NEVER START THE ENGINE WITH FUEL RETURN HOSE DISCONNECTED. THE INTERNAL CHECK VALVE IN THE RETURN FUEL FITTING WILL CREATE EXCESSIVE PRESSURE AND WILL DAMAGE INJECTOR SEALS, CREATING A CATASTROPHIC FAILURE.**

### Applications

- **Removing Fuel**
- **Priming after filter service**
  - Eliminates the use of hand priming pumps after performing maintenance
  - Uses onboard fuel to prime engines and filters, avoids the hassle of keeping reserve fuel on hand
  - Eliminates cross contamination of fuel
- **Fuel Transfer:** Filters and transfers fuel in one operation
  - Transfers fuel when repairing tanks or crossover lines
  - Transfers fuel for trucks being sold or taken out of service
- **Tank Cleaning:** Removes contaminated fuel, sediment and water from fuel tanks of diesel powered equipment or from diesel storage tanks
  - Cleans fuel tanks during service — can be a value added service or a new revenue stream
  - Eliminates downtime due to fuel contamination

### Shop Pro Filtration

- All-in-one fuel filter and water separator for diesel fuel
- “SEEING IS BELIEVING”® Clear cover provides instant visual indication of filter life
- Superior fuel/water separation
- Dry filter changes — drain fuel below collar and replace filter
- Easy to access drain
- Aluminum construction — lightweight and corrosion resistant
- All Shop Pro Functions filter the fuel to 7 microns

### Features

- **Cart**
  - Custom heavy duty construction design
  - Portable and self-contained
  - Integrated drip reservoirs with drains
- **Electrical**
  - UL® listed, rear-facing receptacle
  - Waterproof ON/OFF switch
  - 120VAC connection
- **Pump and Motor**
  - Electric motor/pump combination rated for continuous operation
  - UL listed® and CSA approved
- **Regulator**
  - Pressure Range is 40-45 PSI and 80-85 PSI

### Service Parts

Refer to pages 16 and 17 for service parts. Call DAVCO customer service at 800-328-2611 to order.

**SHOP PRO® COMPONENTS**

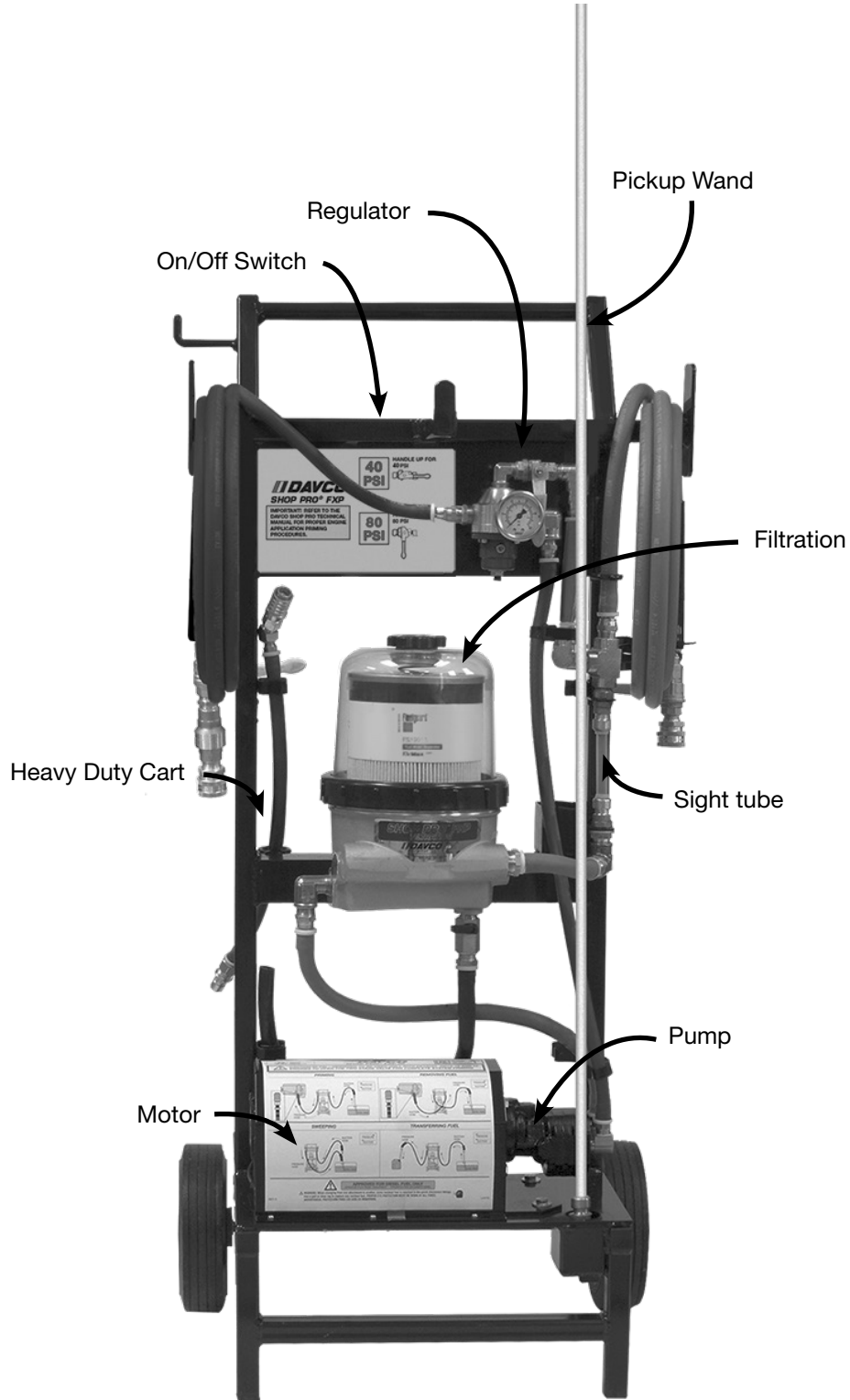

## SET-UP AND MAINTENANCE

### Set-up

1. Unwrap the Shop Pro FXP and remove cable ties from hoses.
2. Assemble the suction hose to the pick-up wand.
3. Remove the vent cap from the filtration unit.

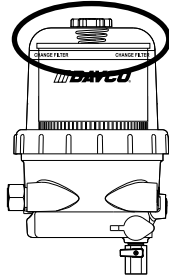

4. Pour diesel fuel into the clear cover until it reaches the black band on the filter element (approximately 1 gallon). (This fuel will be on the “dirty” side of the filter, meaning that the fuel will be filtered before flowing through the Shop Pro FXP to the engine or tank.)
5. Reinstall the vent cap and tighten by hand until it clicks. The Shop Pro FXP is now ready for use.

### Filtration Unit Maintenance

#### Drain Water

Water that has been separated from fuel will collect in the bottom of the body of the filtration unit. Drain the water periodically. This will depend on how often the Shop Pro is used and the quality of the fuel it has filtered.

1. Open the vent cap slightly to break the vacuum. Place the end of the drain hose in a suitable container and open the drain valve.



2. When only fuel is coming out of the hose, shut the valve. Hand tighten the vent cap until it clicks.

### Filter Replacement

Replace the filter in the filtration unit when the fuel remains at the top of the filter element. The filter change will also include replacement of the seals on the vent cap and on the collar.

1. Remove the vent cap and open the drain valve to drain the fuel below the collar level.
2. Remove the collar (use the DAVCO wrench) then remove the clear cover. Remove the filter. Remove the seals from the cover and the vent cap. Dispose of the filter and the seals properly.
3. Using a clean shop rag, clean the cover, vent cap, collar and threads on the filtration unit body. Do not use any acetone based cleaners on clear cover.
4. Install the new filter and the seals (included with the replacement filter).
5. Place the collar over the cover. Simultaneously apply pressure to the top of the clear cover and turn the collar until it is seated on the body of the filtration unit. Tighten the collar until it no longer spins freely. Using the collar wrench, tighten the collar two additional ribs.
6. Pour clean fuel into the filtration unit. Hand tighten the vent cap until it clicks.

Replacement filter part numbers:

Fleetguard: FS19915

### Cart Maintenance

1. Open the small drain valves on the bottom of the reservoirs on the cart. Dispose of waste fluid properly.
2. Wipe the surfaces with shop rags.

## ⚠ IMPORTANT SAFETY PRECAUTIONS

### ⚠ General Safety Precautions

- Read all instructions before use to avoid injury.
- To avoid serious injury or death, follow the safety information in this document.
- Keep this manual. If you need to replace the manual, call customer service at 800-328-2611 or visit [www.davco.com](http://www.davco.com) for a replacement.
- Read all product safety labels.
- Refer to appropriate regulations for environmental and workplace safety rules.

### ⚠ CAUTION:

- The Shop Pro is only approved for use with diesel fuel. It is **not** approved for use with gasoline or any other flammable liquids.

### ⚠ WARNING: MX ENGINES

- **NEVER START THE ENGINE WITH FUEL RETURN HOSE DISCONNECTED. THE INTERNAL CHECK VALVE IN THE RETURN FUEL FITTING WILL CREATE EXCESSIVE PRESSURE AND WILL DAMAGE INJECTOR SEALS, CREATING A CATASTROPHIC FAILURE.**



### ⚠ WARNING: To prevent personal injury



- **Eye Protection:** Proper eye protection must be worn when operating the Shop Pro.
- **Avoid fuel spillage:** When disconnecting attachments equipped with quick disconnect fittings, wrap a shop rag around the fitting to catch any residual fuel. Allow fuel to drain back into hoses before closing ball valves to avoid spillage when returning hoses to the cart.
- Do not leave the Shop Pro running unattended. Follow engine manufacturer guidelines for proper priming procedures. Always disconnect the power supply when the Shop Pro is not in use.
- **Scalding hazard:** When diesel fuel is circulated through an operating engine, it can become very hot. Do not allow fuel to come in contact with eyes or unprotected skin. Allow the engine and fuel to cool to ambient temperature before replacing the fuel filter or performing service operations which could result in spillage of fuel from the fuel system.
- **Fire Prevention:** Heated fuel can form combustible vapor mixtures in the area around the fuel source. To eliminate the potential for fire, keep open flames, sparks or other potential ignition sources away from the work area. Do not smoke during filter replacement or service operations.
- **Inhalation Precaution:** Always perform engine or vehicle fuel system maintenance in a well ventilated area that is kept free of bystanders.
- The ignition key must be in the **off** position, unless otherwise directed. To avoid unintentional engine startup, use a lockout key and/or signage to alert personnel that work is being performed.
- The Shop Pro is to be used with only diesel fuel. Do not use the Shop Pro with gasoline or any other combustible fluid.



## Government Regulations

- Engine fluids (oil, fuel, and coolant) may be a hazard to human health and the environment. Handle all fluids and other contaminated materials (such as filters and rags) in accordance with applicable regulations. Recycle or dispose of engine fluids, filters, and other contaminated materials according to applicable regulations.

## HOSES AND ADAPTERS

HOSES				
HOSE	CONNECTION	USAGE	ADAPTER	PHOTO
Red	Quick Disconnect	Pressure side hose from Shop Pro 1/2" ID	Dispensing wand Priming Voss adapter with red hose	
Green	Quick Disconnect	Suction Side hose from Shop Pro 5/8" ID	Pick-up wand sweeping or fuel transfer, removing fuel  Voss adapter with green hose	

ADAPTERS				
HOSE	CONNECTION	USAGE	HOSE	PHOTO
Blue	Compucheck	Engine fuel module compucheck fitting for priming engine fuel module.	Pressure hose (RED)	
White tube	Quick Disconnect	Pick-up wand: Put in fuel tank or container	Suction hose (GREEN)	
White tube	Quick Disconnect	Dispensing Wand: Tank sweeping or fuel transfer	Pressure hose (RED)	

Adapters for MX 13 EPA 2010, MX 11 EPA 2013 & MX 13 EPA 2013 Engine Applications				
Clear tube	Quick Disconnect	MX 11 EPA 2013 & MX 13 EPA 2013 Engines Clean Fuel "Adapter A"		
Black and clear hose adapter	Quick Disconnect	MX 13 EPA 2010 Engine Return Fuel "Adapter B"		

## **PRIMING THE PACCAR MX 11 EPA 2013 & MX 13 EPA 2013 ENGINE**

**THE FUEL PRIMING PROCEDURE FOR THE MX 13 EPA 2010, MX 13 EPA 2013 & MX 11 EPA 2013 ENGINE IS ON THE RETURN FUEL SIDE OF THE FUEL SYSTEM.**

⚠ **Ensure the fuel tank has sufficient fuel level to ensure proper priming.**

If the Truck has a DAVCO “Fuel Pro”, drain the filter per Tech Manual instructions.



If the truck has a Racor “PACCAR” filter drain the filter per PACCAR instructions.

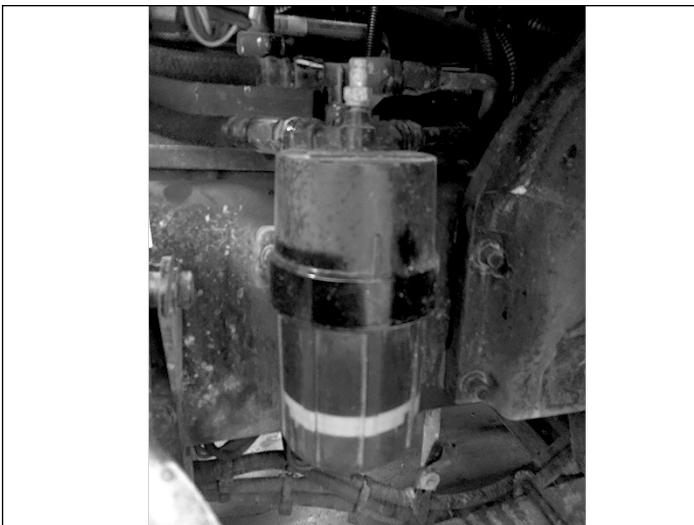

Remove on engine filter per PACCAR instructions.





**PRIMING THE PACCAR MX 11 EPA 2013 & MX 13 EPA 2013 ENGINE**

**THE FUEL PRIMING PROCEDURE FOR THE MX 13 EPA 2010, MX 13 EPA 2013 & MX 11 EPA 2013 ENGINE IS ON THE RETURN FUEL SIDE OF THE FUEL SYSTEM.**

**MX 11 EPA 2013 & MX 13 EPA 2013 Engines**

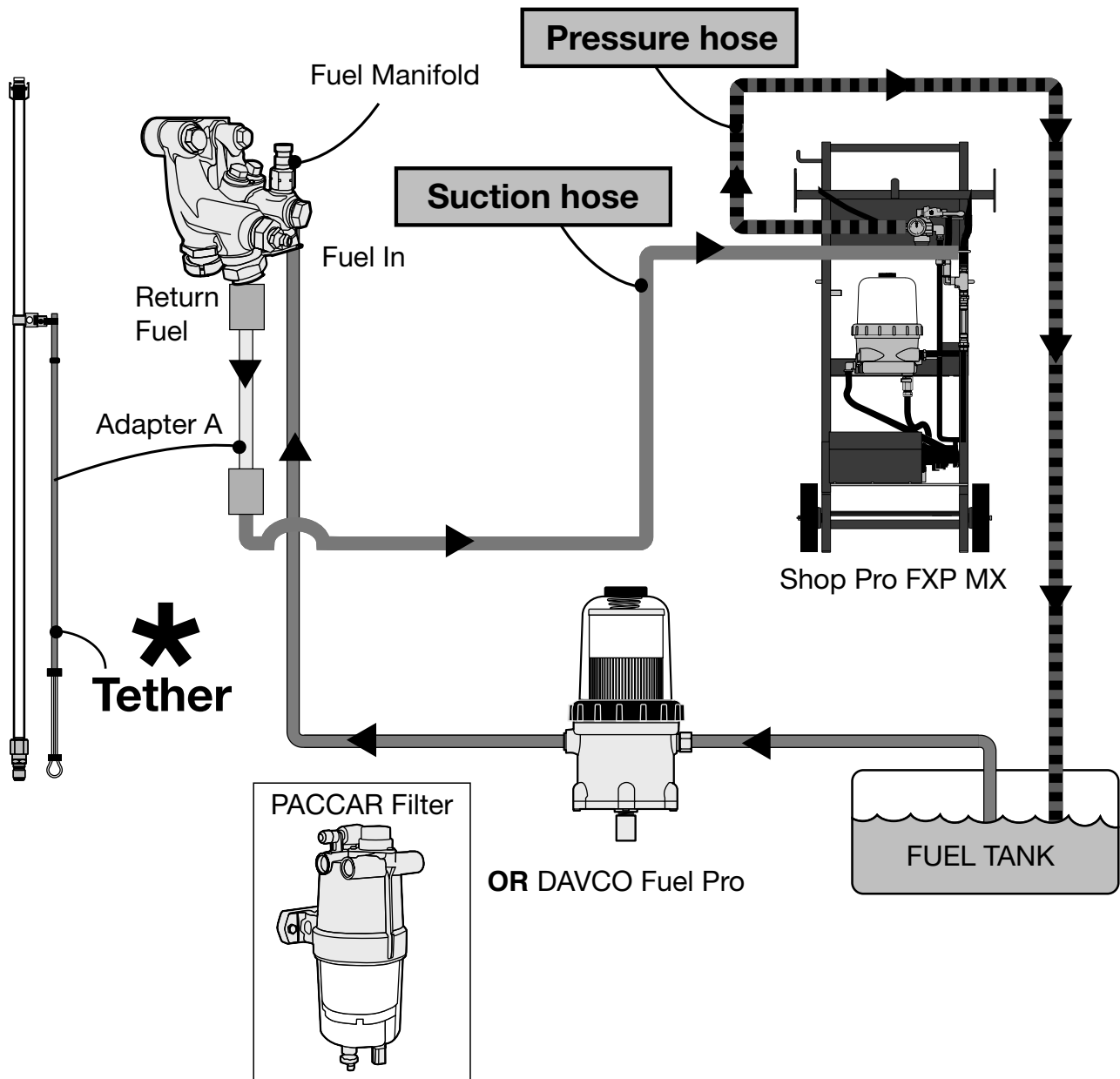

## PRIMING THE PACCAR MX 11 EPA 2013 & MX 13 EPA 2013 ENGINES

**THE FUEL PRIMING PROCEDURE FOR THE MX 13 EPA 2010, MX 13 EPA 2013 & MX 11 EPA 2013 ENGINE IS ON THE RETURN FUEL SIDE OF THE FUEL SYSTEM.**

**⚠ WARNING! NEVER START THE ENGINE WITH FUEL RETURN HOSE DISCONNECTED. THE INTERNAL CHECK VALVE IN THE RETURN FUEL FITTING WILL CREATE EXCESSIVE PRESSURE AND WILL DAMAGE INJECTOR SEALS, CREATING A CATASTROPHIC FAILURE.**

1. Disconnect the "C" clip on the Return Fuel Hose. Remove the hose from the fuel manifold.

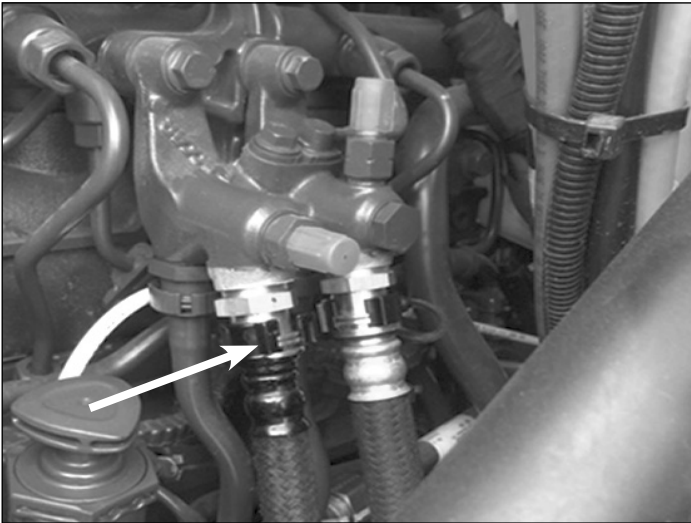

2. Secure the green tether to the Return Fuel Hose. Remove the dust cover from adapter "A" and place on the Return Fuel Hose to keep out contaminants.



3. Connect adapter "A" to the (GREEN) suction hose of the Shop Pro and to the Return Fuel manifold port.

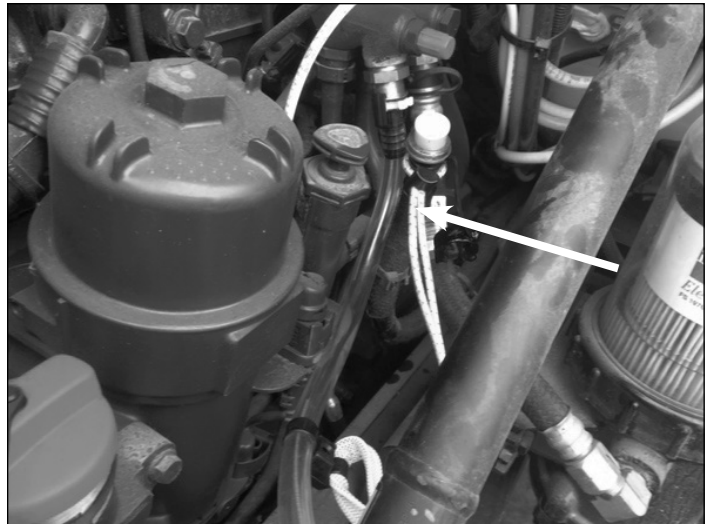

4. Loop adapter "A" hose over the steering shaft for better visibility.



## **PRIMING THE PACCAR MX 11 EPA 2013 & MX 13 EPA 2013 ENGINES**

**THE FUEL PRIMING PROCEDURE FOR THE MX 13 EPA 2010, MX 13 EPA 2013 & MX 11 EPA 2013 ENGINE IS ON THE RETURN FUEL SIDE OF THE FUEL SYSTEM.**

5. Connect the short pickup wand to the Shop Pro (Red) discharge hose. Remove the fuel tank cap and Insert the wand into the fuel tank and open the ball valve. Connect the extension cord to the Shop Pro and turn on. Run the Shop Pro for a minimum of five minutes.



6. Turn off the Shop Pro. Close the ball valve on adapter "A" and Shop Pro suction hose (Green). Remove the Shop Pro suction hose (Green) and reconnect the Return Fuel Hose and insert the "C" clip. Close the ball valve on the (Red) discharge hose, remove wand from the fuel tank and replace fuel cap. Loosen the hand primer pump and pump the handle 10 times to pressurize the injectors. Tighten the primer pump handle in the down position. Start the engine. If the engine will not start after 10 seconds pump the hand primer pump an additional ten times.

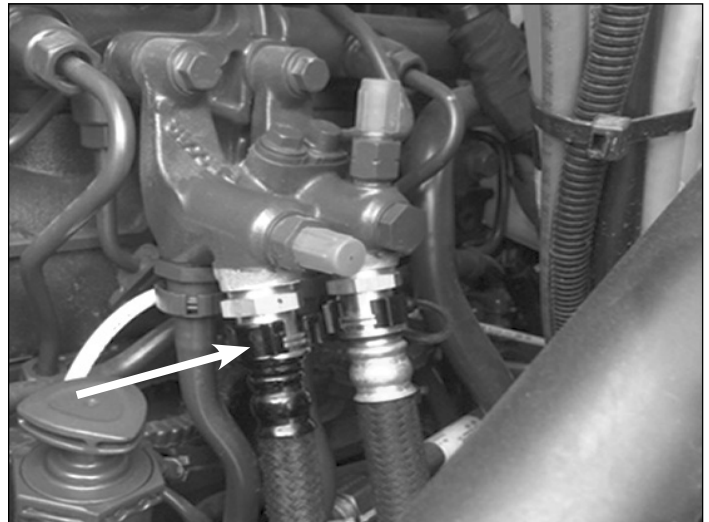

**PRIMING THE PACCAR MX 13 EPA 2010 ENGINE**

**THE FUEL PRIMING PROCEDURE FOR THE MX 13 EPA 2010, MX 13 EPA 2013 & MX 11 EPA 2013 ENGINE IS ON THE RETURN FUEL SIDE OF THE FUEL SYSTEM.**

**MX 13 EPA 2010 Engine**

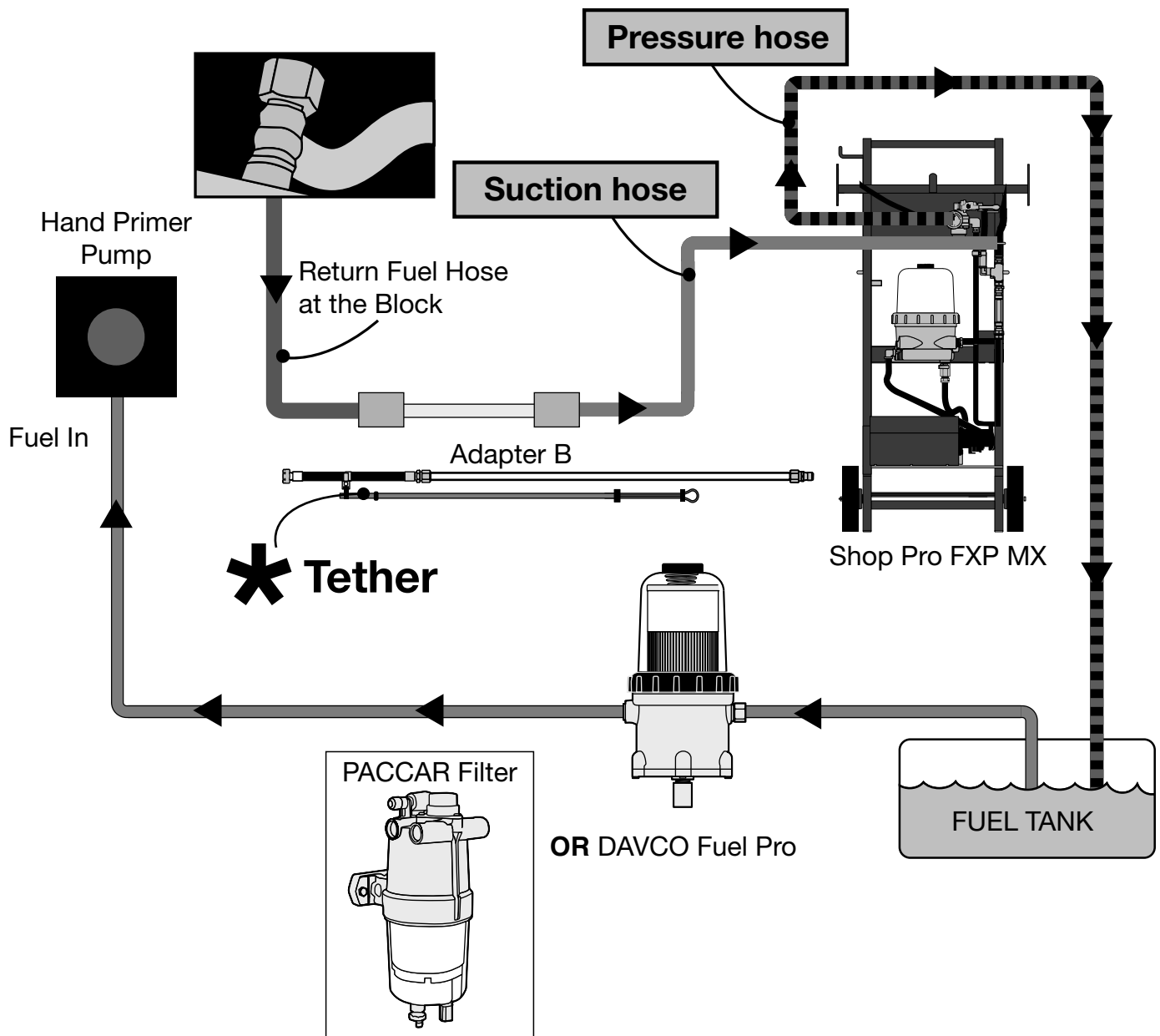

## PRIMING THE PACCAR MX 13 EPA 2010 ENGINE

THE FUEL PRIMING PROCEDURE FOR THE MX 13 EPA 2010, MX 13 EPA 2013 & MX 11 EPA 2013 ENGINE IS ON THE RETURN FUEL SIDE OF THE FUEL SYSTEM.

⚠ **WARNING!** NEVER START THE ENGINE WITH FUEL RETURN HOSE DISCONNECTED. THE INTERNAL CHECK VALVE IN THE RETURN FUEL FITTING WILL CREATE EXCESSIVE PRESSURE AND WILL DAMAGE INJECTOR SEALS, CREATING A CATASTROPHIC FAILURE.

⚠ Ensure the fuel tank has sufficient fuel level to ensure proper priming.

1. Remove and replace the MX 13 EPA 2010 Primary Pac-car Filter or DAVCO Fuel Pro.



2. Remove and replace the MX 13 EPA 2010 Secondary fuel filter.



3. Remove the Return Fuel Hose from the engine block located next to the hand primer pump.

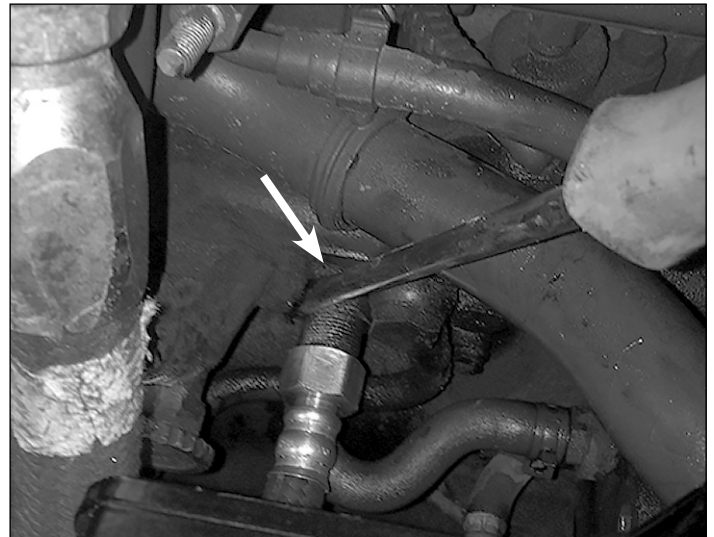

4. Secure the green tether to the Return Fuel Hose. Connect adapter "B" to the engine block fitting and the (Green) suction hose of the Shop Pro.

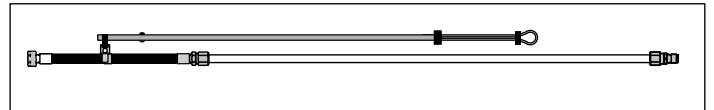

## PRIMING THE PACCAR MX 13 EPA 2010 ENGINE

**THE FUEL PRIMING PROCEDURE FOR THE MX 13 EPA 2010, MX 13 EPA 2013 & MX 11 EPA 2013 ENGINE IS ON THE RETURN FUEL SIDE OF THE FUEL SYSTEM.**

5. Loop adapter “B” hose over the hoses for better visibility.



6. Connect the short pickup wand to the Shop Pro (Red) discharge hose. Remove the fuel tank cap and insert the wand into the fuel tank and open the ball valve. Connect the extension cord to the Shop Pro and turn on. Run the Shop Pro for a minimum of five minutes.



7. Turn off the Shop Pro. Close the ball valve on adapter “B” and Shop Pro suction hose (Green). Remove the Shop Pro suction hose (Green) and reconnect the Return Fuel Hose. Close the ball valve on the (Red) discharge hose, remove wand from the fuel tank and replace fuel cap. Loosen the hand primer pump and pump the handle 10 times to pressurize the injectors. Tighten the primer pump handle in the down position. Start the engine. If the engine will not start after 10 seconds, pump the hand primer pump an additional ten times.

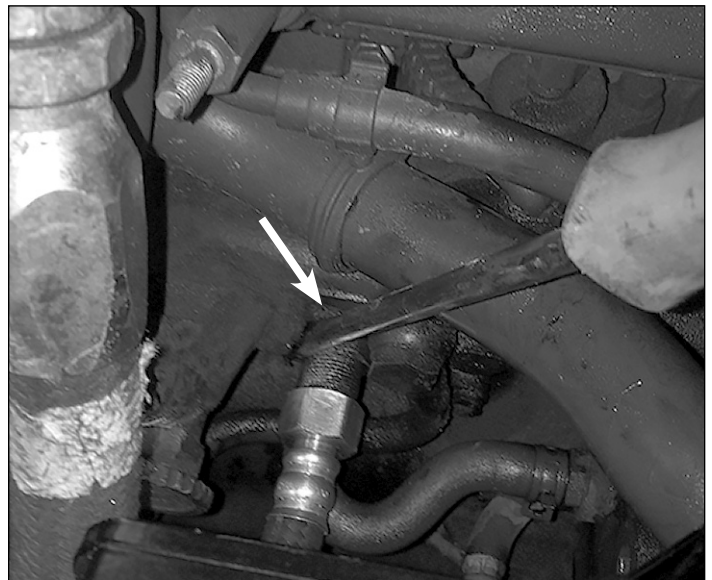

## TANK SWEEPING WITH FILTRATION

### Overview:

The suction hose (GREEN) is connected to the pick-up wand (longer white wand). The pressure hose (RED) is connected to the dispensing wand (shorter white wand). The fuel is filtered as it is pumped from the tank and returned to the same tank. By moving the wand along the sides and bottom of the tank, particles, debris, and contaminants that have settled in the tank are removed. The sight tube aids in determining the length of time needed to clean the tank.

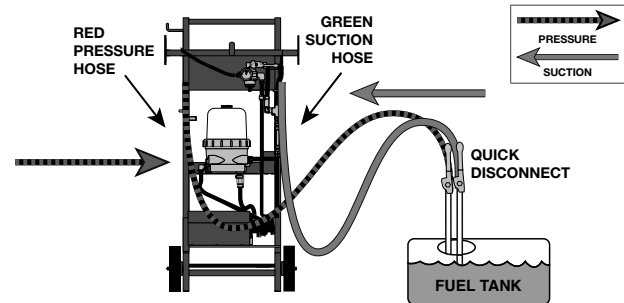

**⚠ CAUTION: If excessive water in fuel is being pumped through the Shop Pro, run it with fuel only for up to one minute before shutting off the Shop Pro to prevent gear corrosion.**

1. Connect the Shop Pro FXP to a power source. Attach the pick-up wand to the suction hose (GREEN) and insert into the fuel tank. Open the pick-up wand ball valve.

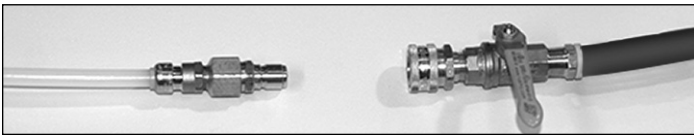

2. Remove the fuel tank fill cap and insert the pick-up wand into the fuel tank. Open the pick-up wand ball valve.



3. Connect the dispensing wand to the pressure hose. Insert the dispensing wand into the fuel tank and open the ball valve.



4. Turn the Shop Pro ON.
5. Slowly sweep the bottom and sides of the fuel tank with a side-to-side motion. Refer to the appearance of the fuel in the sight tube to determine when sweeping is complete. When sweeping is complete, turn the Shop Pro OFF. Remove the pick-up wand from the fuel tank. Allow the fuel to drain back into the tank before closing the ball valves.
6. Return the wands to the Shop Pro cart.

**FUEL TRANSFER WITH FILTRATION**

**Overview:**

The suction hose (GREEN) is connected to the pick-up wand (longer white wand). The pressure hose (RED) is connected to the dispensing wand. The fuel is filtered as it is pumped from the tank (or storage container) and into another tank (or storage container). Any debris, particles, or contaminants that have settled in the tank will be removed as the fuel is transferred between tanks.

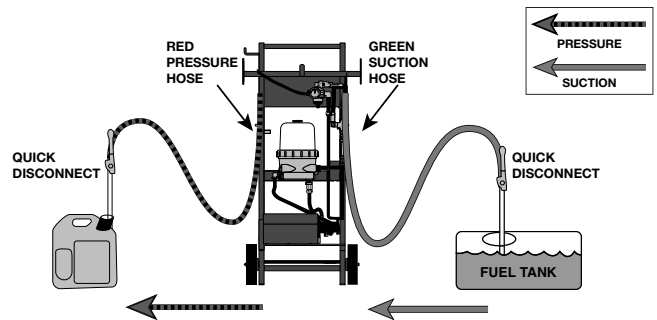

**⚠ CAUTION: If excessive water in fuel is being pumped through the Shop Pro, run it with fuel only for up to one minute before shutting off the Shop Pro to prevent gear corrosion.**

1. Connect the Shop Pro to a power source.
2. Attach the pick-up wand to the suction hose (GREEN) and insert into the fuel tank. Open the pick-up wand ball valve.

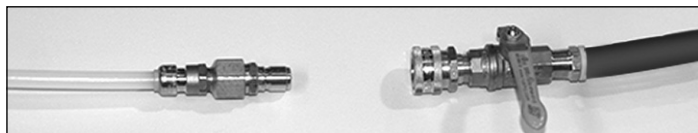

3. Attach the dispensing wand to the pressure hose (RED). Insert the dispensing wand into the fuel tank or container that the fuel is to be transferred to. Open the ball valve.







4. Turn the Shop Pro ON.
5. When the fuel transfer is complete, turn the Shop Pro OFF. Close the ball valve on the dispensing wand and return it to the cart.
6. Remove the pick-up wand from the fuel tank. Allow the fuel to drain back into the tank before closing the ball valves. Close the ball valve on the pick-up wand and return it to the cart.



## SERVICE PARTS

### Adapters

A	CompuCheck Adapter (Blue)	782294PAC	
B	Voss Fitting Adapter (Red)	782293PAC	
C	Angled Voss Adapter (Green)	782292PAC	
D	Pick-Up Wand (60" tube)	782289PAC	
E	Dispensing Wand (23" tube)	782288PAC	

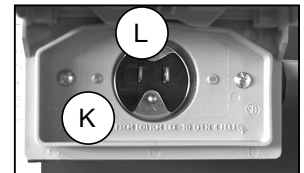

### Cart

F	Plugs (10) 1" x 1" Sq	782196PAC
G	Gripper Clips & Screws	782213PAC
H	Motor Cover and (5) Screws	782126PAC-B
	Motor Fasteners (Not Shown)	782225PAC
	Petcocks (2) (Not Shown)	782197PAC
	Pump Bkt, Washers & Screws (Not Shown)	782214PAC-B
I	Wheels (2), Pins & Washers	782194PAC

### Electrical

J	Coupler Asm	782058PAC
K	Electrical Box w/Switch	782061PAC
L	Electrical Switch	782215PAC
	Motor (Not Shown)	782001PAC
M	Pump	782002PAC

### Fuel Filtration



N	Cover, Collar, Vent Cap and O-rings	782157PAC
O	Drain Valve	102008
P	Filtration Unit	782141PAC
Q	Regulator Asm	782305-1PAC
R	Fuel Filter-Fleetguard	FS19915
S	Sight Glass Kit	782149PAC
T	Wrench	482017

### Hoses

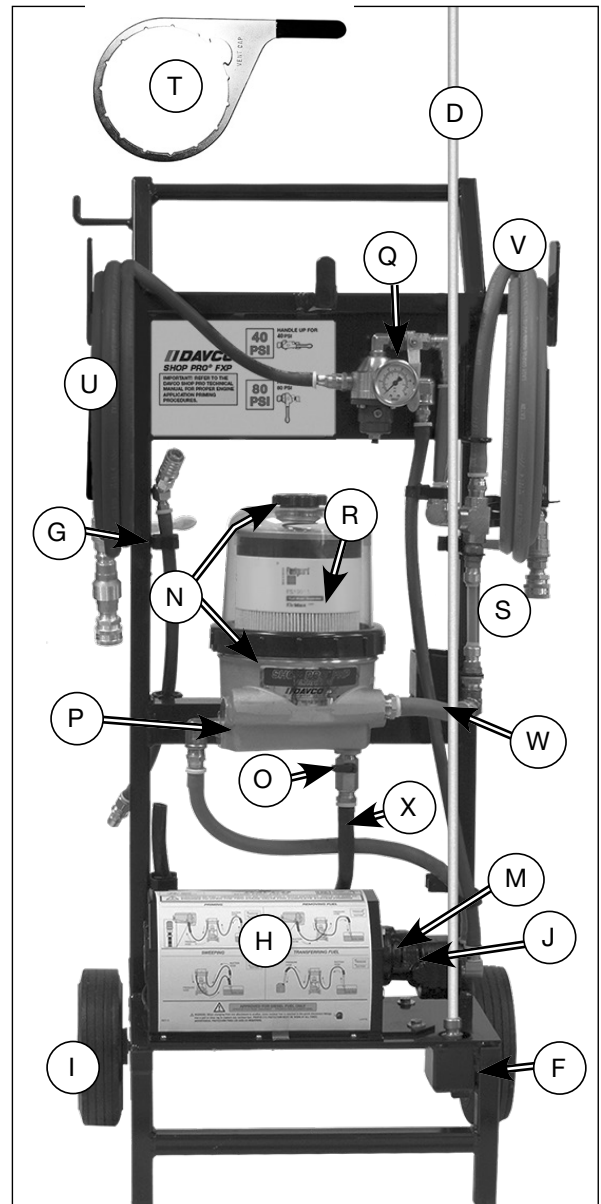
U	Pressure Hose (RED) 17 ft.	782286PAC
V	Suction Hose (GREEN) 12 ft.	782287PAC
W	Hose Kit (Sight Glass, Sight Glass-Filter, Pump-Filter)	782212PAC
X	Drain Hose	782144PAC

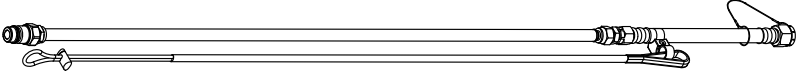

**SERVICE PARTS FOR PRIMING MX ENGINES**

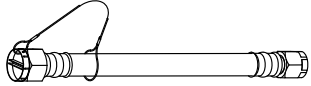
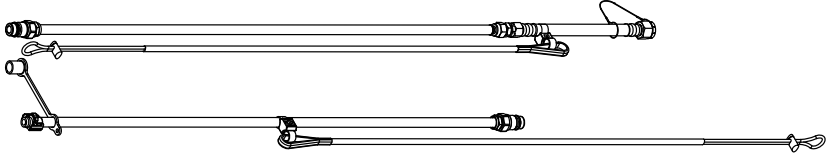
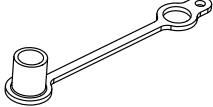
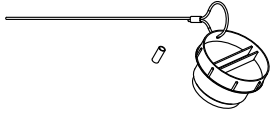
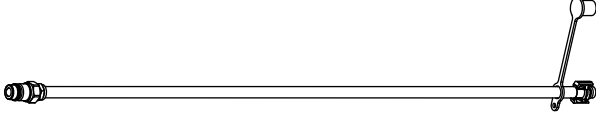
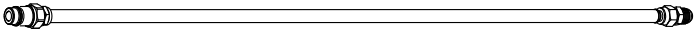
Kit, Mx EPA 13 Engine (Entire accessory)	782301PAC	
Kit, Tether	782303PAC	
Kit, Priming Hose	782304PAC	
Kit, Mx Engine Priming (Entire accessory)	782306PAC	
Kit, Dust Cap	782310PAC	
Kit, Tethered Cap	782311PAC	
Kit, Priming Hose	782312PAC	
Kit, Priming Hose	782313PAC	

## WARRANTY POLICY

Please review DAVCO's Product Warranty terms and conditions carefully before installing and/or using a DAVCO product.

### **Diesel Pro® 243, Diesel Pro® 245, Fuel Pro® 382, Fuel Pro® 482, Fuel Pro® 483, Fuel Pro® 485, Fuel Pro® 487, Industrial Pro®, Pro-Chek®, Sea Pro®**

DAVCO Technology, LLC warrants these products to be free of defects in material and workmanship for five years, 500,000 miles or 10,000 hours (whichever comes first) and electrical parts for two-years, 200,000 miles or 4,000 hours (whichever comes first) from the purchase date\*.

### **Shop Pro®**

DAVCO Technology, LLC warrants the Shop Pro (except for the motor) to be free of defects in material and workmanship for two years from the date of purchase. The Shop Pro motor is warranted for one year from date of purchase.

### **REN Products, EyeMax® and Fuel Pro® 384**

DAVCO Technology, LLC warrants these products to be free of defects in material and workmanship for two-years or 200,000 miles (whichever comes first) from the purchase date.

By installing and/or using the product, you agree to be bound by the following:

### **This Warranty does not apply to:**

- Failure or inadequate performance due to improper installation, misuse, misapplication, faulty installation, alteration/modification, poor maintenance, neglect, accident, or conditions resulting from actions outside DAVCO's control, including but not limited to the use of contaminated, corrosive, and unapproved fluids.
- Downtime, loss of use, loss of profits or income, loss of capital, cost of substitute equipment, living expenses, claims by purchaser's customers or other third parties, or other incidental, special or consequential damages.
- Attachments, accessory items, and parts not manufactured or distributed by DAVCO.
- Any aftermarket or OEM component not approved specifically to work with a DAVCO manufactured product
- Product that has been installed with aftermarket parts or altered or modified in any way.
- Normal wear and tear, abuse, vandalism, acts of God, improper storage or handling, disasters such as flood, fire, or war, failure to operate, maintain or repair in accordance with instructions, or failure to repair the vehicle into which the product is installed in accordance with the vehicle manufacturer's instructions or common maintenance practices.

This warranty is the sole warranty made by DAVCO. DAVCO makes no other warranties, expressed or implied, of merchantability or fitness for a particular purpose.

In the unlikely event of a defective product, DAVCO will either rework the defective product or replace it at DAVCO's discretion. If you feel you have a warrantable issue, contact DAVCO at 800-328-2611 for a Return Goods Authorization (RGA) number \*\*. An RGA number is required prior to the return of any product.

\* Purchase Date: The date of the first retail purchase of a new vehicle or piece of equipment from the OEM dealer or factory. For "Over the Counter" purchase: The date of sale to the first retail customer.

\*\*Products submitted for Warranty consideration will be inspected by DAVCO personnel. Re-work or replacement will be based on DAVCO's Warranty procedure and/or the results of their evaluation. DAVCO's Warranty Program does not in any way constitute a product guarantee.

## PARTS RETURN POLICY

### Parts Return General Policy

**Note:** A Return Goods Authorization (RGA) must be obtained from DAVCO prior to returning any products. Returns may be accepted under the following circumstances:

**Order Shipping Error:** A credit against the original invoice, including freight charges for both ways will be issued for returns in which DAVCO inadvertently shipped incorrect quantity or product.

**Overstock:** Returns for ordering more product(s) than required, or incorrect part(s), will be accepted within 60 days from the date of purchase. Proof of purchase will be required, i.e.: original invoice/delivery receipt. These types of return(s) are subject to a minimum restock fee of 40% or \$40.00, whichever is higher. Additional restock fees may apply. Product(s) will be inspected for “like new” condition and additional costs will be the responsibility of the customer. No obsolete parts may be returned.

Freight charges for return(s) will be the responsibility of the customer.

