

1.5 AMP GENERAL PURPOSE SILICON DIODES

FEATURES

- Low cost
- Low leakage
- Low forward voltage drop
- High current capacity
- Easily cleaned with freon, alcohol, chloroethene and similar solvents
- **RoHS COMPLIANT**

MECHANICAL DATA

- Case: JEDEC DO-15 molded epoxy (U/L Flammability Rating 94V-0)
- Terminals: Plated axial leads
- Soldering: Per MIL-STD 202 Method 208 guaranteed
- Polarity: Color band denotes cathode
- Mounting Position: Any
- Weight: 0.01 Ounces (0.4 Grams)

MECHANICAL SPECIFICATION

ACTUAL SIZE OF
DO-15 PACKAGE

SERIES 1N5391 - 1N5399

DO - 15

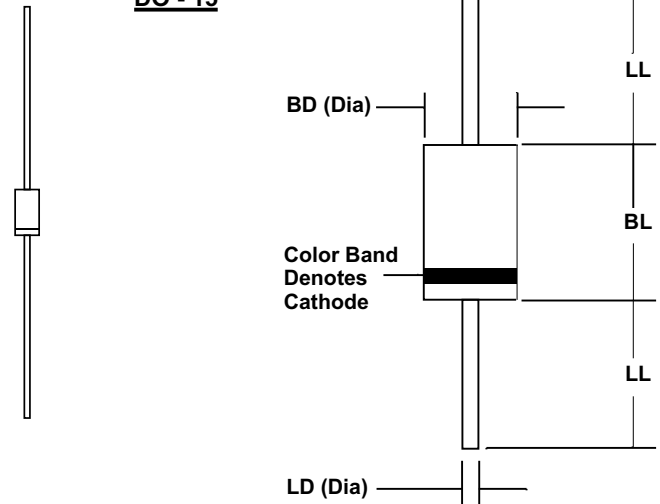

Sym	Minimum		Maximum	
	In	mm	In	mm
BL	0.240	6.01	0.255	6.48
BD	0.130	3.3	0.140	3.6
LL	1.00	25.4		
LD	0.028	0.71	0.034	0.86

MAXIMUM RATINGS & ELECTRICAL CHARACTERISTICS

Ratings at 25 °C ambient temperature unless otherwise specified.
 Single phase, half wave, 60Hz, resistive or inductive load.
 For capacitive loads, derate current by 20%.

PARAMETER (TEST CONDITIONS)	SYMBOL	RATINGS								UNITS
		1N5391	1N5392	1N5393	1N5395	1N5397	1N5398	1N5399		
Series Number										
Maximum DC Blocking Voltage	V _{RM}	50	100	200	400	600	800	1000		VOLTS
Maximum RMS Voltage	V _{RMS}	35	70	140	280	420	560	700		
Maximum Peak Recurrent Reverse Voltage	V _{RRM}	50	100	200	400	600	800	1000		
Average Forward Rectified Current @ T _A = 75 °C, Lead length = 0.375 in. (9.5 mm)	I _O	1.5								AMPS
Peak Forward Surge Current (8.3 mSec single half sine wave superimposed on rated load)	I _{FSM}	60								
Maximum Forward Voltage at 1.5 Amps DC	V _{FM}	1								VOLTS
Maximum Full Cycle Reverse Current @ T _L = 75 °C (Note 1)	I _{RM(AV)}	30								μA
Maximum Average DC Reverse Current @ T _A = 25°C At Rated DC Blocking Voltage @ T _A = 100°C	I _{RM}	5 50								
Typical Thermal Resistance, Junction to Ambient (Note 1)	R _{θJA}	50								°C/W
Typical Junction Capacitance (Note 2)	C _J	30								pF
Operating and Storage Temperature Range	T _J , T _{STG}	-65 to +175								°C

NOTES: (1) Lead length = 0.375 in. (9.5 mm)
 (2) Measured at 1MHz & applied reverse voltage of 4 volts

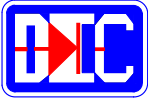

1.5 AMP GENERAL PURPOSE SILICON DIODES

RATING & CHARACTERISTIC CURVES FOR SERIES 1N5391 - 1N5399

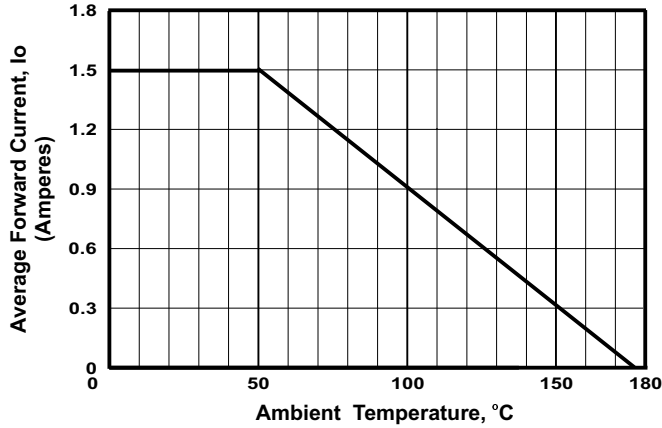

FIGURE 1. FORWARD CURRENT DERATING CURVE

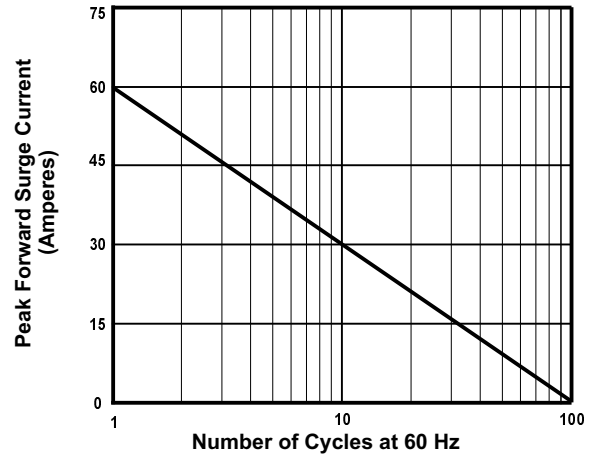

FIGURE 2. MAXIMUM NON-REPETITIVE SURGE CURRENT

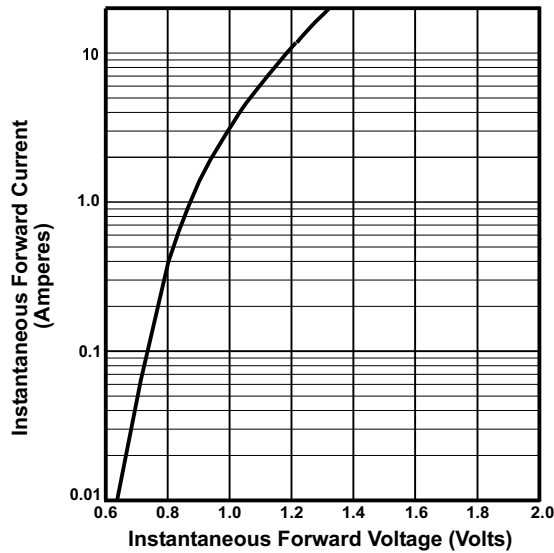

FIGURE 3. TYPICAL FORWARD CHARACTERISTIC PER DIODE

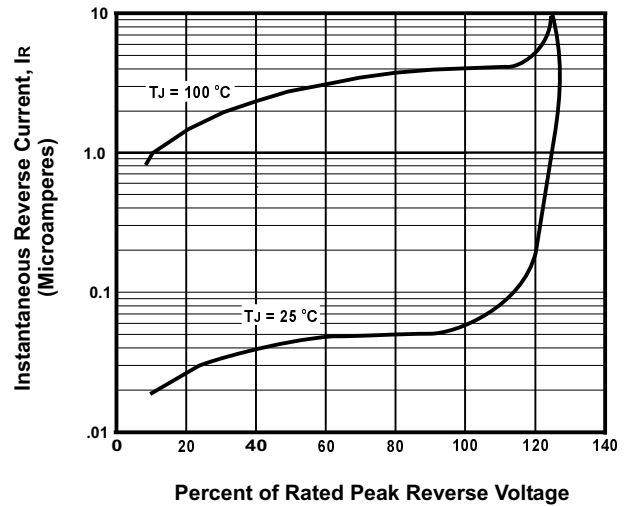

FIGURE 4. TYPICAL REVERSE CHARACTERISTICS

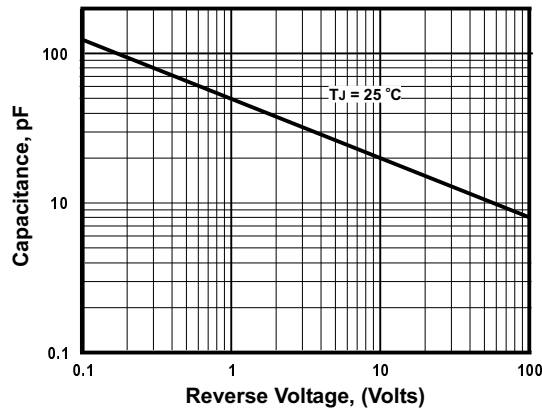

FIGURE 5. TYPICAL JUNCTION CAPACITANCE PER DIODE