

Series 3800

Restrained Coupling

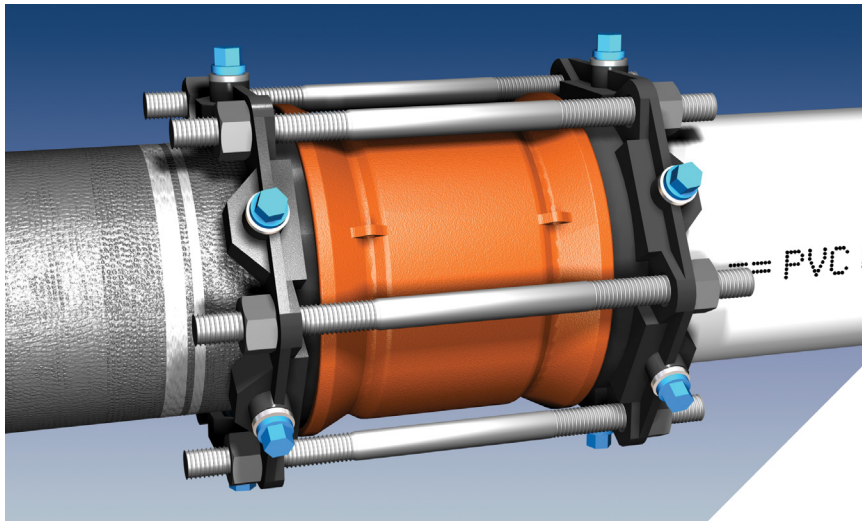

Image depicts Series 3806 on 6 inch ductile iron pipe and 6 inch PVC pipe.

The Series 3800 are designed to restrain forces based on the maximum working pressure ratings listed in the Pressure Ratings Table.

Forces experienced due to expansion/contraction of the pipe require special consideration.

For use on water or wastewater pipelines subject to hydrostatic pressure and tested in accordance with either AWWA C600 or ASTM D2774.

Features and Applications:

- For use on:
 - Ductile Iron Pipe, 4 in. - 48 in.
 - C900 or ASTM D2241 PVC Pipe, 4 in. - 12 in.
 - C905 PVC Pipe, 14 in. - 36 in.
 - Carbon Steel Pipe, 4 in. - 12 in.
 - HDPE Pipe, 4 in. - 12 in.
- Minimum 2 to 1 Safety Factor
- **MEGA-BOND®** Restraint Coating System
For more information regarding MEGA-BOND, refer to our web site at www.ebaa.com
- Constructed of ASTM A536 Ductile Iron
- Corrosion Resistant, low alloy, high strength steel bolts and nuts per ANSI/AWWA C111/A21.11
- Couplings meets or exceeds the applicable requirements of:
 - AWWA C219
 - ASTM A536
 - ANSI/AWWA C111/A21.11
 - ASTM D2000

Nominal Pipe Size	Series Number	Shipping Weight	Ductile Iron Pipe	Steel Pipe	Pressure Ratings (PSI)									
					HDPE Pipe			C900 PVC Pipe			C905 PVC Pipe			
					DR11	DR13.5	DR17	DR14	DR18	DR25	DR18	DR25	DR32.5	DR41
4	3804	36.50	350	350	160	130	100	305	235	165	-	-	-	-
6	3806	49.40	350	350	160	130	100	305	235	165	-	-	-	-
8	3808	67.93	350	350	160	130	100	305	235	165	-	-	-	-
10	3810	85.46	350	350	160	130	100	305	235	165	-	-	-	-
12	3812	103.98	350	350	160	130	100	305	235	165	-	-	-	-
14	3814	157.18	350	-	-	-	-	-	-	-	235	165	125	80
16	3816	183.02	350	-	-	-	-	-	-	-	235	165	125	80
18	3818	201.64	250	-	-	-	-	-	-	-	200	165	-	-
20	3820	229.93	250	-	-	-	-	-	-	-	200	165	-	-
24	3824	364.24	250	-	-	-	-	-	-	-	165	165	125	100
30	3830	540.60	250	-	-	-	-	-	-	-	-	165	125	-
36	3836	695.90	250	-	-	-	-	-	-	-	-	125	125	-
42	3842	1,219.48	250	-	-	-	-	-	-	-	-	-	-	-
48	3848	1,449.76	250	-	-	-	-	-	-	-	-	-	-	-

Weights units are pounds and are approximate values.

Special Notes For Use On HDPE Pipe

For use on 4 inch through 12 inch HDPE only. The use of a pipe wall stiffening insert is required for use on HDPE pipe. The stiffeners must be sized to encompass the entire bearing length of the restraint devices. Pipe systems must be engineered to prevent movement causing fitting to slide or rotate.

EBA products for HDPE are designed for underground pressurized fluid service and are pressure rated to match the pipe SDR pressure rating, de-rated as appropriate for service temperature. Maximum test pressure limited to pipe rated pressure.

Series 3800 Submittal Reference Drawing 4 in. - 12 in.

EBAA IRON

MADE IN USA

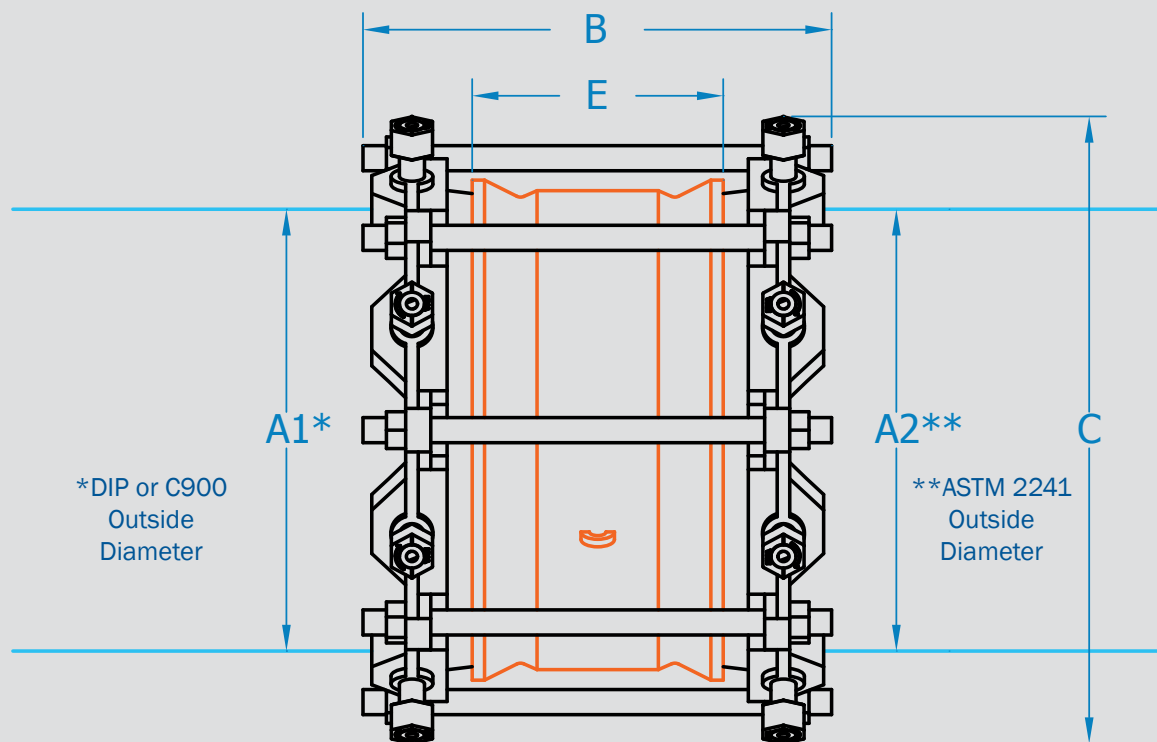

*DIP or C900
Outside
Diameter

**ASTM 2241
Outside
Diameter

Nominal Pipe Size	Series Number	A1* Pipe O.D. (Maximum)	A2** Pipe O.D. (Minimum)	B Overall Length	C† Max. Restraint O.D. (Casing Clearance)	D Thrust Bolt (Number-Size)	E Barrel Length	Maximum Deflection
4	3804	4.80	4.50	14.0	9.5	4 - 3/4 x 14	7.5	4°
6	3806	6.90	6.63	14.0	12.1	6 - 3/4 x 14	7.5	4°
8	3808	9.05	8.63	14.0	13.6	6 - 3/4 x 14	7.5	4°
10	3810	11.10	10.75	14.0	16.0	8 - 3/4 x 14	7.5	4°
12	3812	13.20	12.75	14.0	18.1	8 - 3/4 x 14	7.5	4°

** Requires the use of a Transition Gasket. † As installed with Twist-Off nuts off.
Note: Dimensions are in inches (± 1%) and are subject to change without notice.

Sample Specification

Joint restraint to prevent axial separation shall be incorporated into the design of the sleeve or coupling used to connect two plain ends of same or dissimilar materials, such as Ductile Iron pipe, steel pipe, PVC pipe (C900 or ASTM D2241) and or High Density Polyethylene (HDPE) pipe. Internal pipe wall stiffeners must be used when restraining HDPE.

The restraint mechanism shall incorporate a plurality of individually actuating gripping surfaces to maximize restraint capability, and have torque limiting twist off nuts to insure proper actuating of the restraint devices. The restraint devices shall be coated using MEGA-BOND®. For complete specifications on MEGA-BOND visit www.ebaa.com.

The coupling sleeve internal surfaces (wetted parts) shall be lined with a minimum of 15 mils of fusion bonded epoxy conforming to the applicable requirements of ANSI/AWWA C213. Sealing gaskets shall be constructed of SBR. The coating shall meet ANSI/NSF-61. Exterior surfaces shall be coated with a minimum of 6 mils of fusion bonded epoxy conforming to the applicable requirements of ANSI/AWWA C116/A21.16. Ductile Iron components shall meet or exceed the requirements of ASTM A536, and shall be tested in accordance with said standard.

The restrained joining system shall meet the applicable requirements of AWWA C219, ANSI/AWWA C111/A21.11, and ASTM D2000.

The restrained coupling system shall be Series 3800 manufactured by EBAA Iron, Inc.

Series 3800 Submittal Reference Drawing 14 in. - 48 in.

EBAA IRON

MADE IN USA

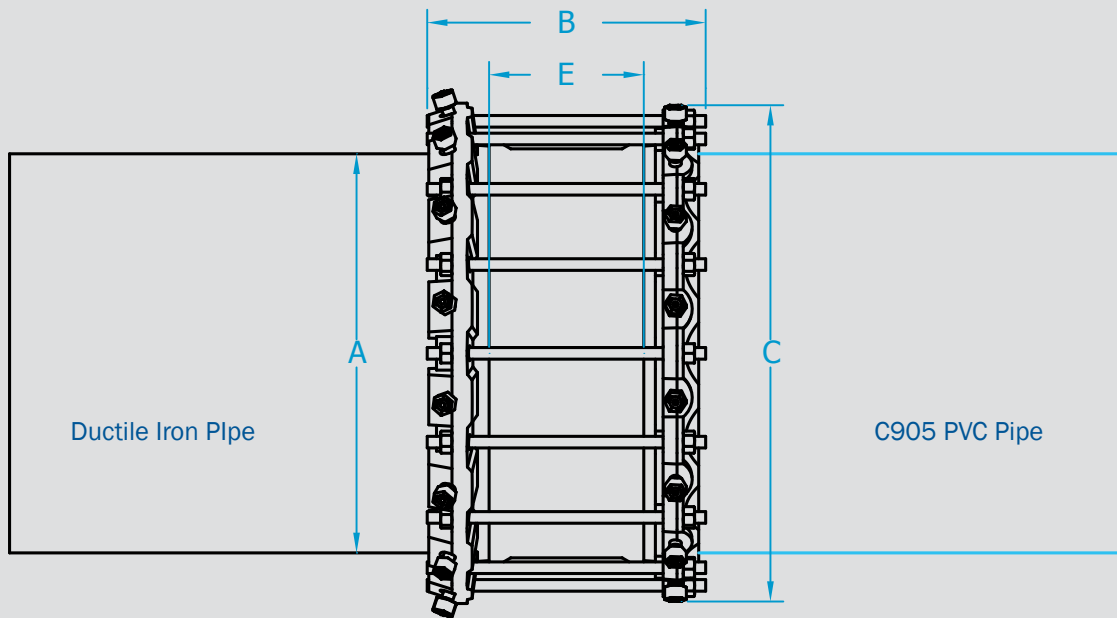

Nominal Pipe Size	Series Number*	A Pipe O.D.	B Overall Length	C** Max. Restraint O.D. (Casing Clearance)	Thrust Bolt (Number-Size)	E Barrel Length	Maximum Deflection
14	3814XX	15.3	18.0	20.94	10 - 3/4 x 18	10.0	4°
16	3816XX	17.4	18.0	23.00	12 - 3/4 x 18	10.0	4°
18	3818XX	19.5	18.0	25.10	12 - 3/4 x 18	10.0	4°
20	3820XX	21.6	18.0	27.20	14 - 3/4 x 18	10.0	4°
24	3824XX	25.8	18.0	32.64	16 - 3/4 x 18	10.0	4°
30	3830XX	32.0	20.0	38.87	20 - 1 x 20	10.0	3°
36	3836XX	38.3	20.0	45.17	24 - 1 x 20	10.0	3°
42	3842XX	44.5	24.0	55.57	28 - 1 1/4 x 24	10.0	1°
48	3848XX	50.8	24.0	61.87	32 - 1 1/4 x 24	10.0	1°

** As installed with Twist-Off nuts off.

*Specifying the Proper Series Number

Note: Dimensions are in inches (± 1%) and are subject to change without notice.

4 inch through 12 inch

For Nominal Pipe Sizes 4 inch through 12 inch the Series 3800 MEGA-COUPLING utilizes a common restraint ring for Ductile Iron Pipe (DIP), C900 PVC Pipe, ASTM D2241 PVC Pipe (IPS), Carbon Steel Pipe, and HDPE Pipe (with internal pipe wall stiffener for HDPE). The only item that needs to be specified during the order process for 4 inch through 12 inch is what type of gasket is required for joint assembly for the various pipe O.D.'s:

- 3800S for coupling either DIP, C900 PVC and or DIP O.D. HDPE Pipe
- 3800T for coupling either Carbon Steel and or ASTM D2241 PVC
- 3800ST for coupling either DIP, C900 PVC or DIP O.D. HDPE Pipe on one side and either Carbon Steel or ASTM D2241 PVC on the other side

14 inch through 48 inch

For Nominal Pipe sizes 14 inch and above the Series 3800 MEGA-COUPLING utilizes the Series 1100 MEGALUG® restraint on DIP and the Series 2000PV MEGALUG restraint on C905 PVC. Since the O.D. of both DIP and C905 PVC is the same, the EBAA-SEAL™ Improved Mechanical Joint Gasket is provided.

- 3800DI for coupling DIP
- 3800PV for coupling C905 PVC
- 3800DIPV for coupling one side DIP and other C905 PVC

Spacer Instructions (4 in. through 12 in. only)

Ductile Iron or C900 PVC O.D. Sized Pipe

For installation on **Ductile Iron or C900 PVC sized pipe**, use as received and install per instructions.

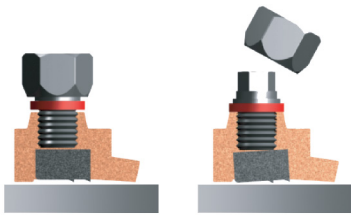

Steel or ASTM D2241 O.D. Sized Pipe (IPS O.D.)

For installation on **Steel or ASTM D2241 O.D. Sized pipe**, remove spacers and replace screws. Install per instructions.

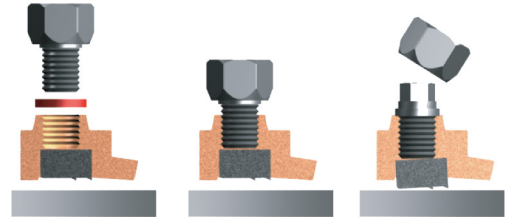

Installation Instructions

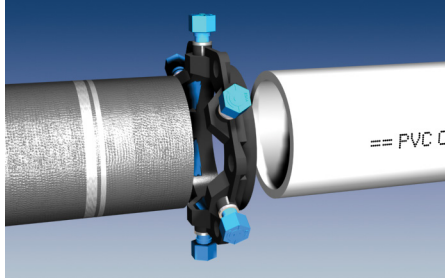

1. Identify the pipe. The spacers under the actuating screws must be removed for use on ASTM D2241 O.D. sized pipe (4 inch through 12 in. only). The spacers must remain in place for use on Ductile Iron or C900 PVC O.D. sized pipe. (See spacer instructions above)

Clean and inspect the pipe ends. Beveling of the ends is not necessary.

If used on HDPE Pipe, a pipe wall stiffener insert that encompass the entire bearing length of the restraint devices must be installed prior to step two.

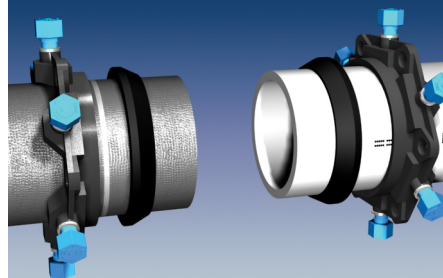

2. Place the end rings on the pipes with the lip extensions toward the pipe ends. For 4 inch through 12 the restraints will be the Series 2000HPV, for 14 inch and above Ductile Iron pipe the restraint ring will be the Series 1100 MEGALUG® and for C905 PVC 14 inch and above the restraint ring will be the Series 2000PV MEGALUG. Lubricate and install the Standard Mechanical Joint Gasket.

(Standard Mechanical Joint Gaskets must be used with Ductile Iron Pipe and C900 PVC pipe 4 inch through 12 inch while the EBAA-SEAL™ Improved Mechanical Joint gasket is used on 14 inch and above. Transition gaskets must be used with Steel or ASTM D2241 pipe).

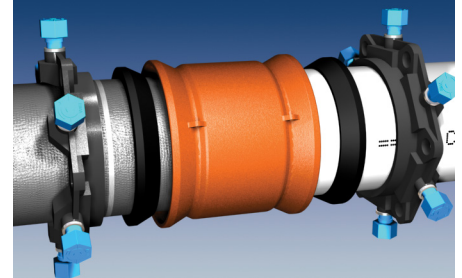

3. Center the sleeve body over the ends of the pipes while maintaining a 1/2" to 1" gap between the pipe ends. Slide the gaskets and end rings toward the sleeve body.

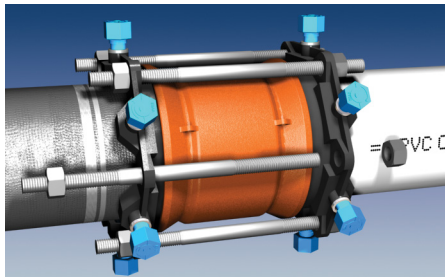

4. Install the threaded rods and hand tighten the nuts on each end. Gradually tighten the nuts in an alternating manner until the proper torque value has been reached, while maintaining the same distance between the rings and the ends of the body at all points around the rings. For 4 inch through 24 inch torque to 75-90 ft.-lbs., for 30 and 48 inch torque to 120-150 ft.-lbs.

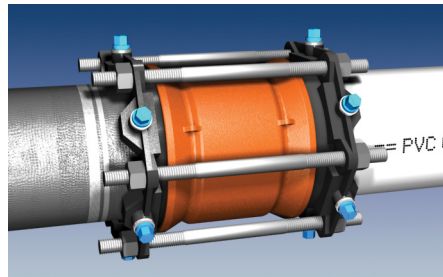

5. Hand tighten the actuating screws until all wedges are touching the pipes. Continue tightening the screws in an alternating manner until the torque limiting heads twist off. The screws may bottom out during this step.



EBAA IRON Sales, Inc.

P.O. Box 857, Eastland, TX 76448

Tel: (254) 629-1731

Fax: (254) 629-8931

(800) 433-1716 within US and Canada

contact@ebaa.com

www.ebaa.com