

Series 1700

MEGALUG® Restraint Harness
for Push On Joints on Ductile Iron Pipe

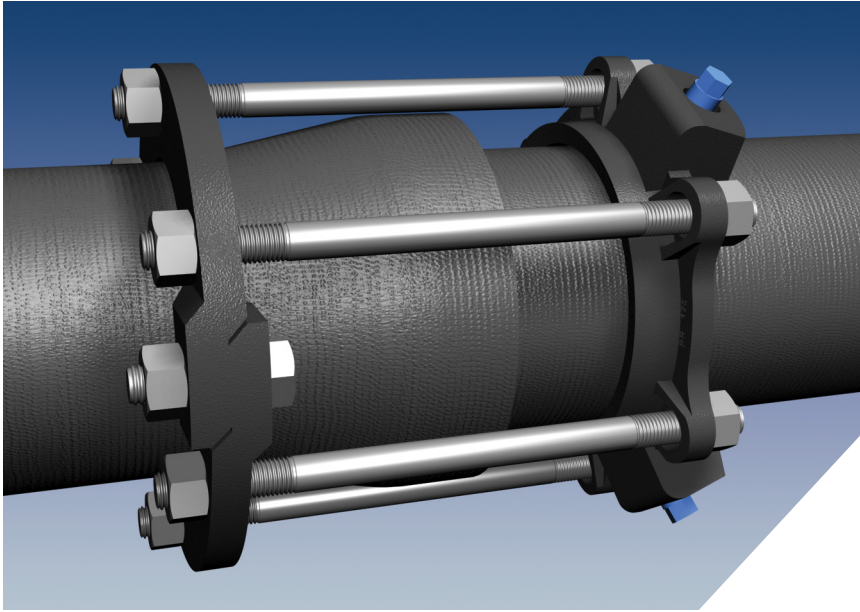

Series 1706 restraining 6 inch ductile iron pipe to pipe push on joint.

Features and Applications:

- Restraint harness for ductile iron pipe to pipe push on joints
- Restraint harness meets or exceeds ANSI/AWWA C151A21.51 and ANSI/AWWA C150/A21.50 standards
- Minimum 2 to 1 safety factor
- MEGALUG Restraint Ring on spigot side of joint
- Split Bell Ring design for ease of installation
- Constructed of ASTM A536 ductile iron
- MEGA-BOND® Restraint Coating System

For use on water or wastewater pipelines subject to hydrostatic pressure and tested in accordance with either AWWA C600 or ASTM D2774.

Sample Specification

Ductile iron pipe bell restraint shall consist of a wedge action restraint ring on the spigot joined to a split ductile iron ring behind the bell. The restraint ring shall have individually actuated wedges that increase their resistance to pull-out as pressure or external forces increase. The restraint ring and its wedging components shall be made of ductile iron conforming to ASTM A536. The wedges shall be heat treated to a minimum hardness of 370 BHN. Torque limiting twist off nuts shall be used to insure proper actuation of the restraining wedges. The split ring shall be made of ductile iron conforming to ASTM A536. The restraint devices shall be coated using MEGA-BOND®. (For complete specifications on MEGA-BOND visit www.ebaa.com.) The connecting tie rods that join the two rings shall be made of low alloy steel that conforms to ANSI/AWWA C111/A21.11. The assembly shall have a rated pressure with a minimum two to one safety factor of 350 PSI in the sixteen inch size and below 250 PSI in the eighteen through thirty-six inch sizes. The product shall be the Series 1700 MEGALUG® restraint harness, manufactured by EBAA Iron, Inc., or approved equal.

Nominal Pipe Size	Series Number	PSI Ratings	
		Approximate Shipping Weight	Rated Pressure (PSI)
3	1703	16.91	350
4	1704	19.96	350
6	1706	28.92	350
8	1708	37.92	350
10	1710	56.34	350
12	1712	74.02	350
14	1714	119.62	350
16	1716	134.40	350
18	1718	138.40	250
20	1720	161.88	250
24	1724	242.36	250
30	1730	312.00	250
36	1736	475.00	250
42	1742*	1,131.00	250
48	1748*	1,345.00	250

NOTES: For applications for pressure other than those shown, please contact EBAA for assistance.

* Series 1742 and 1748 consist of two MEGALUGS, one on the spigot and one behind the bell.

EBAA IRON Sales, Inc.

P.O. Box 857, Eastland, TX 76448

Tel: (254) 629-1731

Fax: (254) 629-8931

(800) 433-1716 within US and Canada

contact@ebaa.com

www.ebaa.com

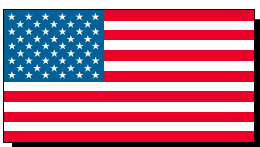

Series 1700 Submittal Reference Drawing

EBAA IRON

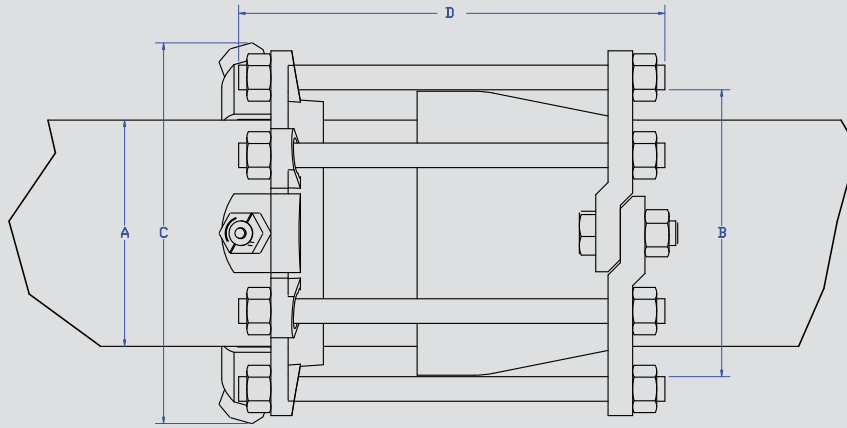

MADE IN USA

Nominal Pipe Size	Series Number	A Pipe O.D.	B Maximum Bell O.D. Cleared	C Casing Clearance (w/Nuts Off)	D Thrust Rod (Quantity - Size)
3	1703	3.96	5.44	9.06	4 - 5/8 - 12
4	1704	4.80	6.60	9.90	4 - 3/4 x 13
6	1706	6.90	8.60	12.00	6 - 3/4 x 13
8	1708	9.05	10.9	14.15	6 - 3/4 x 13
10	1710	11.10	13.1	16.20	8 - 3/4 x 18
12	1712	13.20	15.4	18.30	8 - 3/4 x 18
14	1714	15.30	17.9	21.88	8 - 3/4 x 18
16	1716	17.40	20.1	24.13	10 - 3/4 x 18
18	1718	19.50	22.4	26.50	10 - 3/4 x 18
20	1720	21.60	24.6	28.50	12 - 3/4 x 18
24	1724	25.80	29.1	33.38	14 - 3/4 x 18
30	1730	32.00	35.8	40.25	16 - 1 x 18
36	1736	38.30	42.6	46.75	20 - 1 x 18
42	1742*	44.50	49.2	55.57	24 - 1 1/4 x 28
48	1748*	50.80	56.1	61.87	28 - 1 1/4 x 28

*Series 1742 and 1748 are comprised of two MEGALUGS ; one on the spigot and the other behind the bell.
 NOTES: Dimension are in inches and are subject to change without notice.

Installation Instructions

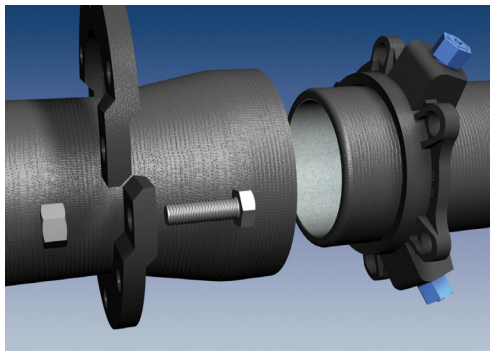

The Series 1700 is designed for restraining ductile iron pipe, conforming to ANSI/AWWA C151/A21.51 (all thickness classes) push-on pipe bells. It has a restraint ring on the spigot and a split ring behind the bell.

1. Install the split ring behind the bell in the direction indicated on the casting. Tighten the clamp bolts to 90 ft-lbs.
2. Place the Series 1100 MEGALUG® restraint gland on the spigot with the lip extension toward the bell.
3. Assemble the push-on joint per the pipe manufacturer's instructions.
4. Position the Series 1100 MEGALUG® restraint on the spigot such that the bolts are in alignment and the distance between the rings is suitable for the tie bolt length. Allow enough room on the tie bolt to fully engage the nuts with several threads showing.
5. Install the tie bolts in each available bolt hole for maximum distribution of operating forces. Place nuts on the end of the tie bolts. Allow room on the tie bolt to fully engage the nut with several threads showing.
6. Pull the restraint ring away from the joint until the slack is removed from the tie bolts.
7. Tighten the torque limiting twist-off nuts in a clockwise direction (direction indicated by arrow on top of nut) until all wedges are in firm contact with the pipe surface. Continue tightening in an alternate manner until all of the nuts have been twisted off.
8. Tighten the tie bolt nuts until the ring behind the bell is in firm contact with the back of the bell. Do not tighten these bolts enough to force the spigot further into the bell.
9. If removal is necessary; use the 5/8 inch hex heads provided. If reassembly is required, assemble the product in the same manner as indicated in the previous steps and tighten the wedge bolts to 90 ft-lbs.

