

# Force Balanced FLEX-TEND®

## Force Balanced Flexible Expansion Joint

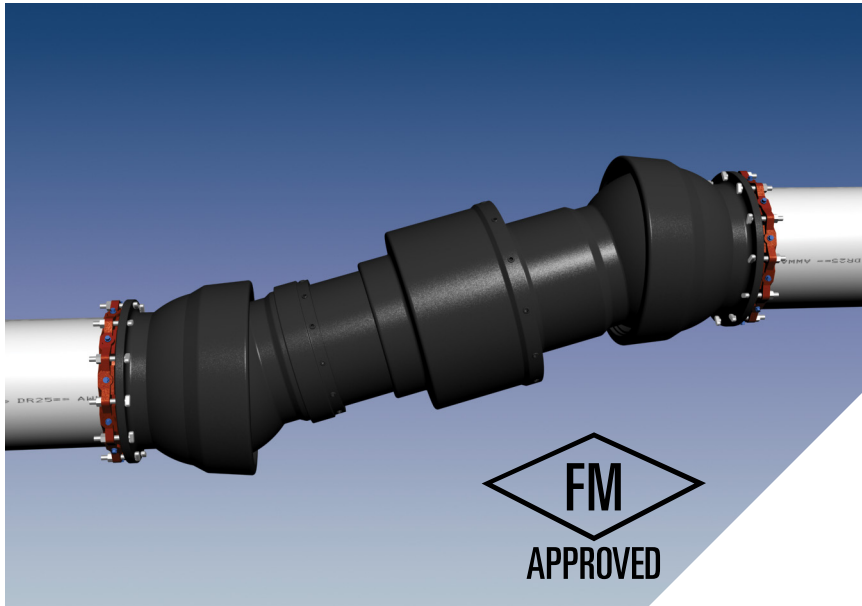

Force Balanced FLEX-TEND; Series 4418M20B, 18 inch Double Ball with Mechanical Joint Ends



Image depicts 8 inch Force Balanced FLEX-TEND

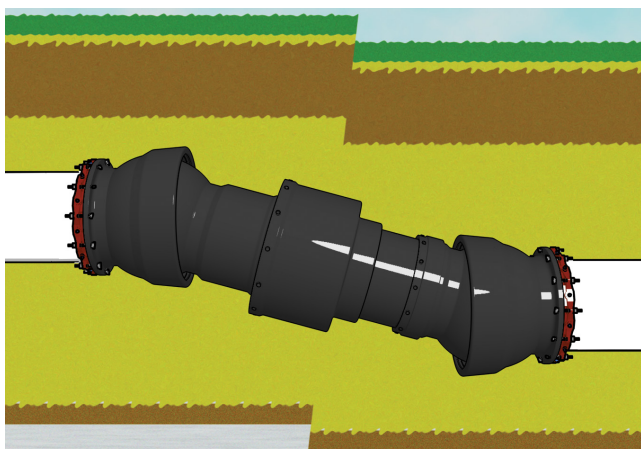

Image depicts direct burial application (Polyethylene wrap not depicted). Refer to "Connections" FT-2 for more details.

### Features and Applications:

- Sizes 2 inch through 36 inch  
Size 2 inch rated at 150 PSI  
Sizes 3 inch through 16 inch rated at 350 PSI  
Sizes 18 inch and above rated at 250 PSI
- For Ductile Iron, Steel, PVC or HDPE pipe
- Expansion unit will NOT impart a thrust force while under internal pressure
- Designed to give Deflection and or Expansion/Contraction needs to protect pipeline systems from shear. Refer to submittal drawings for "offset" capability
- Constructed of ASTM A536 Ductile Iron
- Up to 20° Deflection per ball
- Each unit tested to rated working pressure prior to shipment
- Due to the design of the seals, no periodic maintenance is required
- End connections:  
Flanged; 2 inch through 36 inch  
Mechanical Joint; 4 inch through 24 inch
- Flange outlets conform to the dimensional requirements of ANSI/AWWA C110/A21.10 (class 150) with the addition of an O-ring gasket which is provided to ensure a watertight seal (2 inch units do not have O-rings).
- Mechanical Joint end connections conform to the dimensional requirements of either ANSI/AWWA C111/A21.11 or ANSI/AWWA C153/A21.53 depending on size.
- FLEX-TEND assemblies are suitable for direct burial. Polyethylene wrap is provided with each unit. If installed in a vault, the design must be such that movement is not impeded. Refer to Connections FT-2 found at [www.ebaa.com](http://www.ebaa.com).
- NOT for use on pipelines containing solids and debris.

For use on water pipelines subject to hydrostatic pressure and tested in accordance with either AWWA C600, C605, or ASTM D2774.

## FLEX-TEND, EX-TEND, AND FLEX-900 O-ring Groove

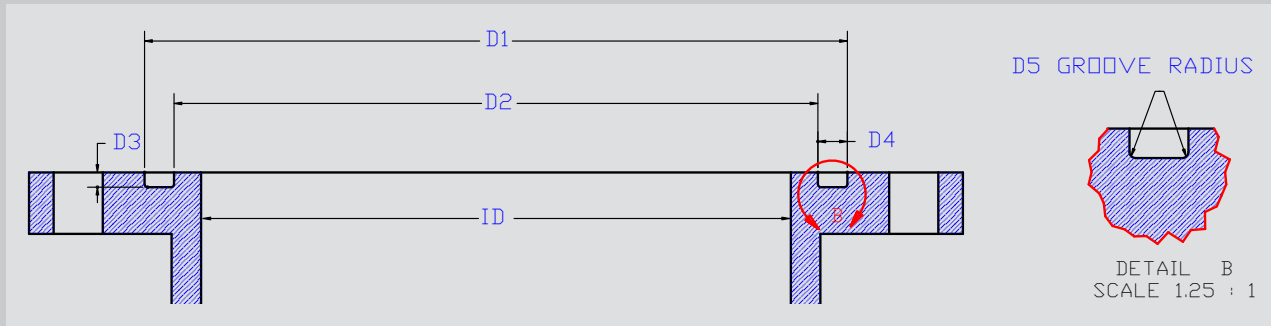

Size	D1	D2	D3	D4	D5	O-ring Diameter	O-ring Part Number
3	4.885	4.185	0.175	0.350	0.0625	0.25	983003
4	5.900	4.700	0.300	0.600	0.0625	0.5	983004
6	8.00	6.800	0.300	0.600	0.0625	0.5	983006
8	10.100	8.900	0.300	0.600	0.0625	0.5	983008
10	12.200	11.000	0.300	0.600	0.0625	0.5	983010
12	14.300	13.100	0.300	0.600	0.0625	0.5	983012
14	16.200	15.00	0.300	0.600	0.0625	0.5	983014
16	18.500	16.900	0.400	0.800	0.1250	0.625	983016
18	20.700	19.100	0.400	0.800	0.1250	0.625	983018
20	23.000	21.400	0.400	0.800	0.1250	0.625	983020
24	27.200	25.600	0.400	0.800	0.1250	0.625	983024
30	33.500	31.700	0.400	0.900	0.1250	0.75	983030
36	40.000	38.300	0.400	0.850	0.1250	0.75	983036
42	46.580	44.080	0.650	1.250	0.1250	N/A	983042
48	52.720	50.220	0.650	1.250	0.1250	1	983048

### Sample Specification

1. Flexible expansion joints shall be installed in the locations indicated on the drawings and shall be manufactured of ductile iron conforming to the material requirements of ASTM A536 and ANSI/AWWA C153/A21.53. Foundry certification of material shall be readily available upon request.
2. Each flexible expansion joint shall be pressure tested prior to shipment against its own restraint to a minimum of 150 PSI for 2 inch, 350 PSI for 3 inch through 16 inch and 250 PSI for 18 inch and greater. A minimum 2:1 safety factor, determined from the published pressure rating, shall apply.
3. Each flexible expansion joint shall consist of an expansion joint designed and cast as an integral part of a ball and socket type flexible joint, having a minimum per ball deflection of: 25°, 2 inch; 20°, 4 inch - 12 inch; 15°, 14+ inch and 6-inches minimum expansion. The flexible expansion fitting shall not expand or exert an axial imparting thrust under internal water pressure. The flexible expansion fitting shall not increase or decrease the internal water volume as the unit expands or contracts.
4. All internal surfaces (wetted parts) shall be lined with a minimum of 15 mils of fusion bonded epoxy conforming to the applicable requirements of ANSI/AWWA C213. Sealing gaskets shall be constructed of EPDM. The coating shall meet ANSI/NSF-61.
5. Exterior surfaces shall be coated with a minimum of 6 mils of fusion bonded epoxy conforming to the applicable requirements of ANSI/AWWA C116/A21.16.
6. Polyethylene sleeves, meeting ANSI/AWWA C105/A21.5, shall be included for direct buried applications.
7. Manufacturer's certification of compliance to the above standards and requirements shall be readily available upon request. The purchaser (or owner) shall reserve the right to inspect the manufacturer's facility for compliance. All flexible expansion joints shall be The Force Balanced FLEX-TEND as manufactured by EBAA Iron, Inc. Eastland, TX., U.S.A.

### Important Notes

The EBAA Force Balanced Flex-Tend® is particularly suited for use in above ground applications where unbalanced thrust forces are neither desirable nor easily accommodated. These applications require special attention to the overall forces and restraint of the piping system.

The installation of a Force Balanced Flex-Tend requires the restraint of all adjacent pipe joints in order to transfer expansion/contraction forces to the unit and to produce the desired force-balancing effect without undue movement or separation of the adjacent joints. Lock-ring type pipe and fitting joints are required to have the assembly clearance removed by extending the joint prior to the installation of the Force Balanced Flex-Tend and pressurization of the system.

Joint restraint and clearance removal of adjacent joints is necessary in both above and below ground Force Balanced Flex-Tend installations.

# FLEX-TEND Force Balanced Submittal Drawing

EBAA IRON

EBAA IRON

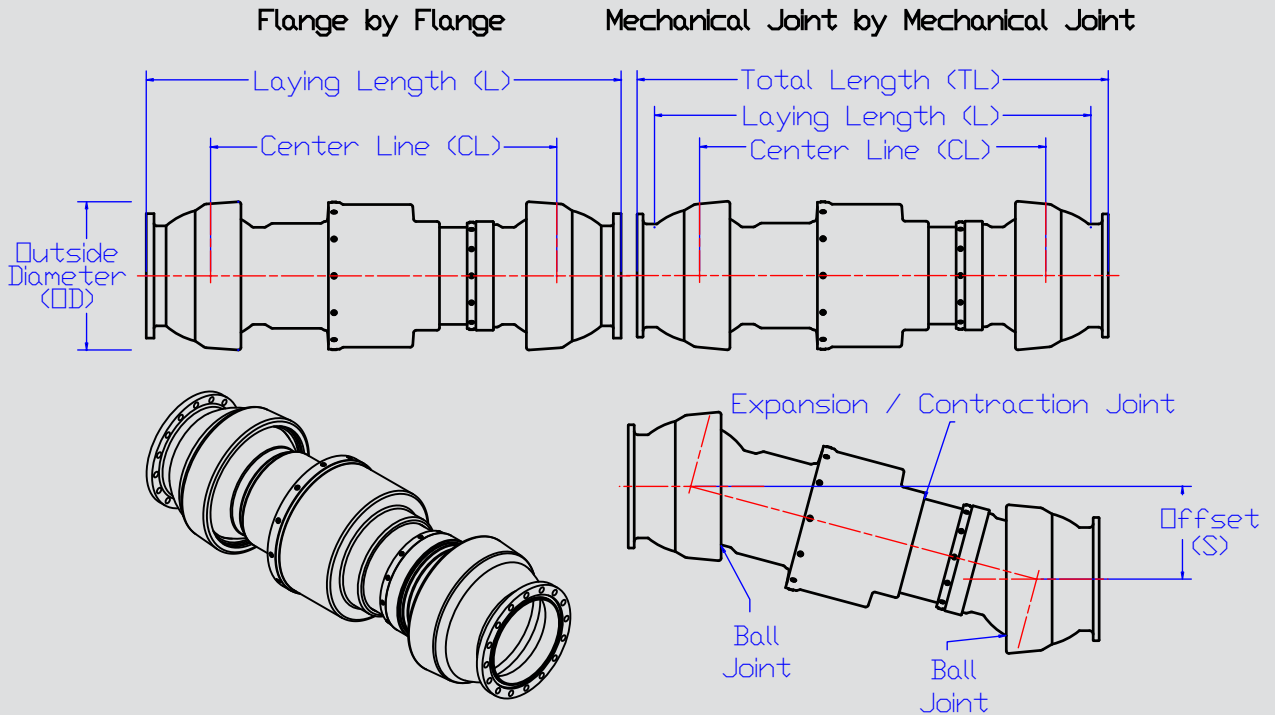

Nominal Pipe Size	OD	D*	E**	CL	S	Flange by Flange			Mechanical Joint by Mechanical Joint			
						Series Number	L	Weight (lbs)	Series Number	L	TL	Weight (lbs)
2	6.20	25°	6.5	43.0	19.7	4402F20B	48.7 (-1.8,+4.7)	48.4	~	~	~	~
3	7.50	20°	8	40.6	15.0	4403F20B	51.2(-3,+5)	130	~	~	~	~
4	10.2	20°	8	42.5	15.9	4404F20B	53.8 (±4)	167	4404M20B	49.7 (±4)	54.7 (±4)	206
6	12.3	20°	8	44.0	16.5	4406F20B	56.8 (±4)	275	4406M20B	52.4 (±4)	57.4 (±4)	316
8	14.9	20°	8	48.1	17.8	4408F20B	62.9 (±4)	377	4408M20B	57.8 (±4)	62.8 (±4)	496
10	18.1	20°	8	50.6	18.7	4410F20B	67.0 (±4)	594	4410M20B	63.0 (±4)	68.0 (±4)	635
12	20.8	20°	8	52.9	19.4	4412F20B	72.0 (±4)	786	4412M20B	66.3 (±4)	71.3 (±4)	880
14	26.5	15°	10	65.3	17.5	4414F20B	91.5 (±5)	1,846	4414M20B	84.6 (±5)	91.5 (±5)	1768
16	26.5	15°	10	65.3	17.5	4416F20B	88.6 (±5)	1,779	4416M20B	86.0 (±5)	93.0 (±5)	1709
18	29.8	15°	10	69.5	18.6	4418F20B	95.4 (±5)	2,573	4418M20B	87.6 (±5)	94.6 (±5)	2431
20	33.1	15°	10	75.0	20.1	4420F20B	95.3 (±6)	2,885	4420M20B	95.7 (±6)	102.7 (±6)	2897
24	39.1	15°	12	81.7	20.6	4424F20B	110.9 (±6)	4,394	4424M20B	109.0 (±6)	116.0 (±6)	4340
30	47.8	15°	16	103.5	28.9	4430F20B	136.8 (±8)	9,224	~	~	~	~
36	59.3	15°	16	105.9	29.5	4436F20B	148.1 (±8)	11,158	~	~	~	~

NOTE: Dimensions are in inches, and are subject to change without notice.  
 End connection combinations available (14 inch - 24 inch).  
 \*Deflection Angle is per ball.  
 \*\* Maximum expansion.





## Force Balanced FLEX-TENDS

Flexible expansion joints have been used for many years with great success. They protect pipelines while crossing shear plains such as seismic faults or protection of a structure's pipeline system from either a seismic event or from gradual soil subsidence. They have however one drawback; they generate an axial imparting force while under pressure. While this imparting force or thrust is easy to accommodate with a pipeline that stretches across a rural landscape, it becomes cumbersome and costly in municipal settings to engineer and build a restraint system that can isolate these imparting thrusts without interfering with the purpose of the unit, which is to protect the pipeline from sudden or gradual movement generated by the environment and not the imparting thrust.

The Force Balanced FLEX-TEND® Flexible Expansion Joint can accommodate pressure induced thrust forces by utilizing an additional water chamber piston that acts in the equal and opposite direction of the imparting thrust and hence neutralizes the thrust forces. This neutralization of the pressure thrust allows designers to use flexible expansion joints in applications where bulky cumbersome thrust blocks or other means of force restricting devices are not applicable. Finally, a flexible expansion joint can now be placed into a system as easily as putting in a spool piece of pipe, rather than having to either dig out large areas for a thrust retaining walls and blocks, or by engineering costly lateral bracing that must be supported by structures that may not have been designed to take these forces.

Another concern is the addition of a needed flexible expansion joint to protect a pipeline system that serves a structure or uses a structure to make a crossing of some type. Most structures, such as water storage tanks, base isolated buildings, and bridges, were not designed to restrain the imparting thrust of a typical expansion joint, thus adding considerable cost in developing a restraint that can isolate the thrust without hampering the unit's ability to move as needed to protect the pipeline. The Force Balanced FLEX-TEND solves all these problems while giving the designer and owner the security of knowing his pipeline systems were protected from shear.

Additionally and just as important, as the unit expands and contracts to accommodate the needs of the pipeline system, the volume inside the unit never changes unlike traditional expansion joints. This is

exceptionally important when protecting base isolated structures such as buildings. A normal expansion unit will increase its volume of water during the expansion stroke, and then reduce that volume during the contraction stroke, in essence creating a 'pumping' action drawing water through the distribution pipe system, through the back flow preventers and forcing it into the structure, possibly causing water damage.

Municipalities are also experiencing a common theme in their maintenance and expansion programs for their water and wastewater needs: Congestion. The sheer amount of buried utilities is already staggering and the future only holds more as cities grow and not only add more buried utilities but increase the size of the existing water and wastewater pipeline systems. In this existing and anticipated congestion, the Force Balanced FLEX-TEND Flexible Expansion Joint can not only protect pipeline systems from movement as any other flexible expansion joint, it can do so with a smaller and overall less expensive footprint, allowing room for the existing or future utilities that may one day join it.

Additional information can be found in *Connections Bulletin* FT-4

### Additional FLEX-TEND Family Products

FLEX-TEND Standard Flexible Expansion Joint

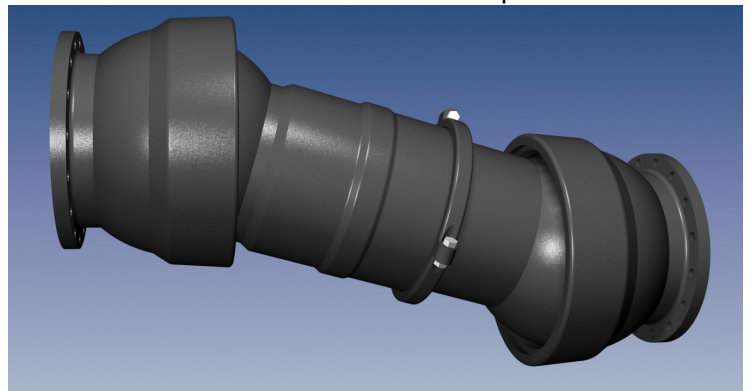

### EBAA IRON Sales, Inc.

P.O. Box 857, Eastland, TX 76448

Tel: (254) 629-1731

Fax: (254) 629-8931

(800) 433-1716 within US and Canada

contact@ebaa.com

www.ebaa.com