

Power Resistors

Series GXP 120, SOT 227

120 W Power Resistor in "ISOTOP" power device (1x120 W/2x50 W/3x30 W acc. configurations)

Thanks to our Non-Inductive Design, these elements are ideally suited for high-frequency and pulse-loading applications. Through direct mounting on a heat sink, significant cost advantages can be realized. Type GXP can be supplied in a two- or four-terminal version. Even triple resistors are available. Main applications are: variable speed drives; power supplies; control devices; telecommunications; robotics; motor controls and other switching devices. Special and custom-designed components upon request.

Specifications

- Resistance range: 0.1 Ω to 1 MΩ
- Tolerance: ±1%, 2%, 5%, 10%
- Temperature coefficient (>1ohm): ±250 ppm/°C (at +105°C ref. to +25°C), better TCR on request
- Max. work. voltage: 500 V (up to 1,000 V upon special request)
- Power rating at 85°C: 120 W (see derating)
- Short time overload: 1.5 x rated power at 85°C bottom case temp. for 10 sec, ΔR = 0.4% max. (for conf. 1, 2 and 3)
- Partial discharge: up to 2,000 Vrms/80 pC
- Voltage proof: dielectric strength up to 4,000 V DC against ground
- Insulation resistance: 10 GΩ Min. at 1 kV DC
- Isolation voltage between R1 and R2: 500 V, 1,000 V upon special request
- Protection class: acc. to IEC 950/CSA22.2 950/ M-89 and EN 60950.88: 2
- Heat resistance to cooling plate: Rth <0.45 K/W
- Capacitance/mass: 45 pF (typical)
- Working temperature range: -55°C to +155°C
- Mounting - max. torque for base plate (static): 1.5 Nm, M4 screws
- Mounting - max. torque for contacts (static): 1.3 Nm, M4 screws
- Housing material acc. to UL94-V0
- Standard storage conditions: 0 to 85°C at 80% RH max. for min. 12 months. For different conditions please contact your local EBG representative!

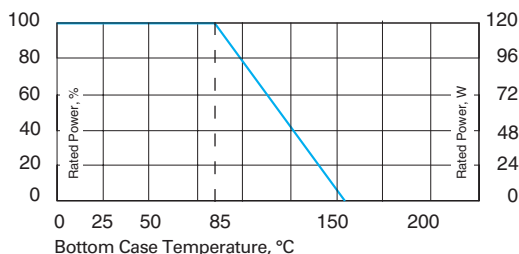

Best results can be obtained by using a thermal transfer compound with a heat conductivity of better than 1 W/mK. The flatness of the cooling plate must be better than 0.05 mm overall. Surface roughness should not exceed 6.4 μm.

Derating (thermal resistance): 2.22 W/°K (0.45°K/W). (for conf. 1, 2 and 3)

Configurations (P/package)

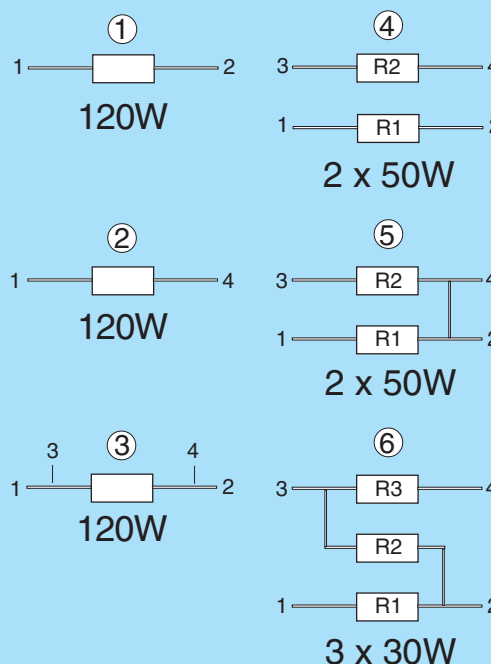

Version 5: ohmic value between contact 2 and 4 = 3 mΩ

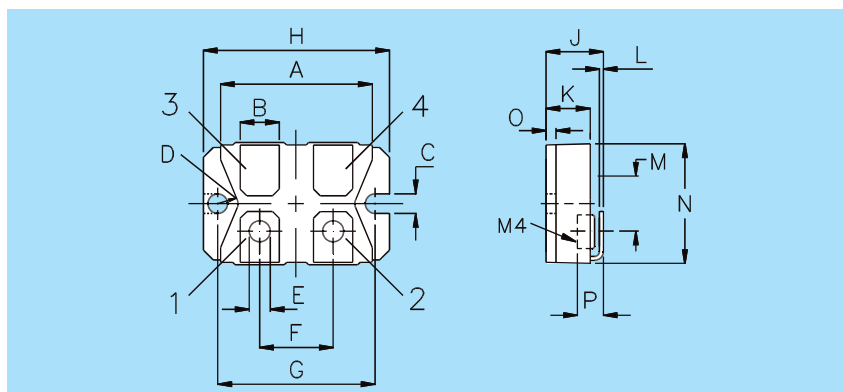

Dim.	Millimeter		Inches	
	Min.	Max.	Min.	Max.
A	31.0	32.0	1.220	1.260
B	7.8	8.2	0.307	0.323
C	4.1	4.3	0.162	0.169
D	4.0	--	0.158	--
E	4.1	4.3	0.162	0.169
F	14.9	15.1	0.587	0.595
G	30.1	30.3	1.186	1.193
H	37.7	38.3	1.484	1.508
J	11.8	12.2	0.465	0.481
K	8.9	9.1	0.351	0.359
L	0.75	0.85	0.030	0.033
M	12.6	12.8	0.496	0.504
N	24.4	25.4	0.960	1.001
O	1.95	2.05	0.077	0.081
P	5.3	--	0.209	--

The above spec. sheet features our standard products. For further options, please contact our local EBG representative or contact us directly. For updated information, please visit our website!