

SML11-XXXX

Drum core, SMT inductor

- Compact design, low height
- Reflow solder rating, 260°C for 10sec
- Inductance range, 1.0uH – 2.2mH
- Temperature range, -40°C to 130°C
- Energy storage, 80 uWsec.
- Packaging, 700pcs, 24mm blisterpack
- RoHS compliant per 2002/95/EC
- Other values available

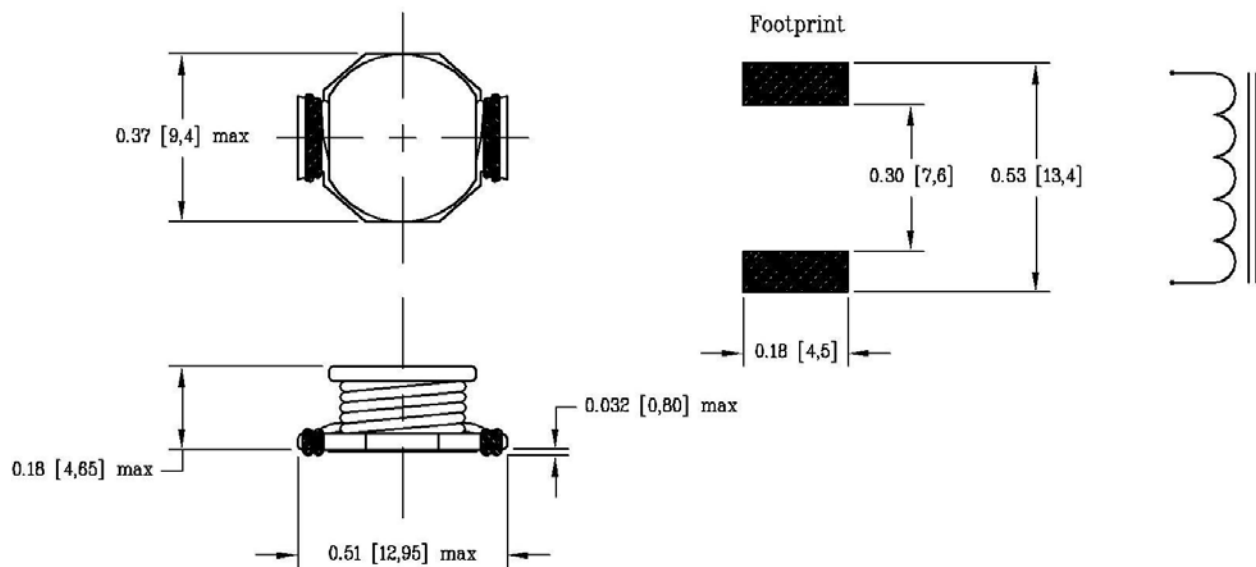

Dash #	“L” (uH)	Tol. (%)	“SRF” min (MHz)	“DCR” max (mΩ)	“I” max (A)
-0000	1.0	20	40	7	10.0
-0001	1.5	20	35	9	8.50
-0002	2.2	20	30	11	8.00
-0003	3.3	20	25	13	6.80
-0005	4.7	20	22	15	5.80
-0007	6.8	20	16	22	4.60
-0010	10	20	12	30	3.80
-0015	15	20	10	40	3.20
-0022	22	20	8	62	2.60
-0033	33	20	6	95	2.00
-0047	47	20	5	115	1.80
-0068	68	20	4	160	1.45
-0082	82	10	3.5	195	1.30
-0100	100	10	2.5	240	1.20
-0150	150	10	2.0	370	1.00

-0220	220	10	1.5	550	0.84
-0330	330	10	1.2	760	0.69
-0470	470	10	1.0	950	0.56
-0680	680	10	0.80	1.8 Ω	0.46
-1000	1000	10	0.50	2.3 Ω	0.39
-1500	1500	10	0.45	3.2 Ω	0.32
-2200	2200	10	0.40	5.0 Ω	0.26

Rev D, 7/07