

SML3-XXXX

Miniature surface mount common mode filter

- Compact design
- “pick & place” surface
- Soldering temperature 230 °C, 5 seconds
- Inductance balanced within 1% (1-2 & 5-4)
- Dielectric strength, 250Vdc between windings
- Temperature class, 130 °C
- Inductance test level, 100kHz @ 10mV
- RoHS compliant per 2002/95/EC
- Packaging, 500pcs, 16mm blisterpack

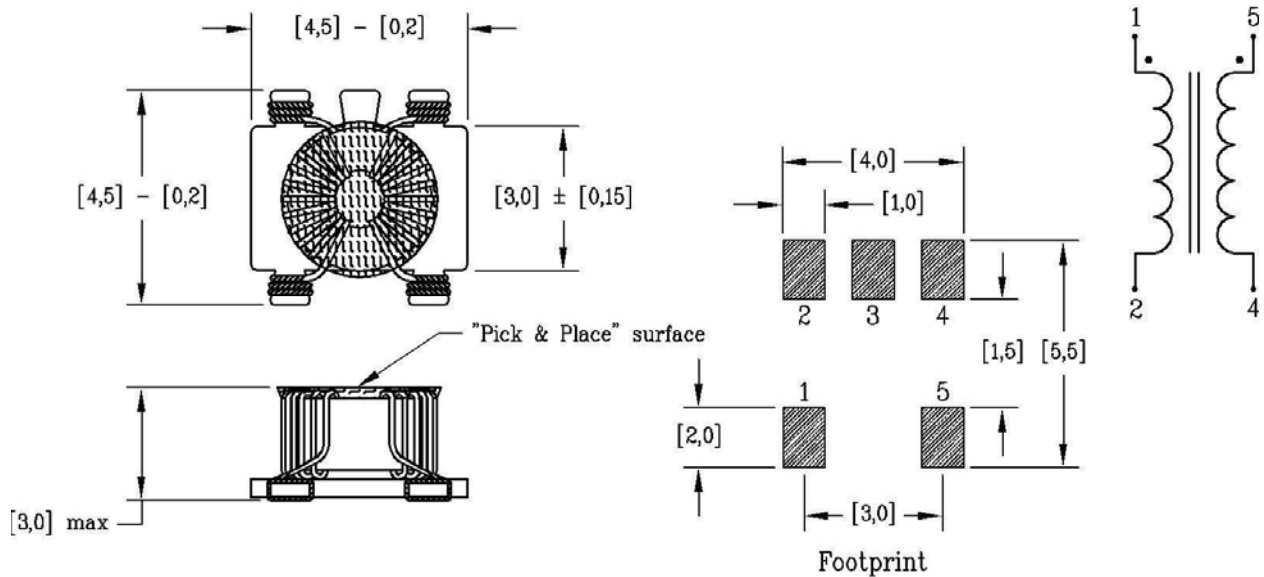

Dash #	“L” +/-30% (uH)	“DCR” max (mΩ)	“I” max (mA)
-0011	11	70	100
-0022	22	100	100
-0033	33	120	100
-0051	51	150	100

INSERTION LOSS ($Z = 50$ Ohms)

SML3-0011

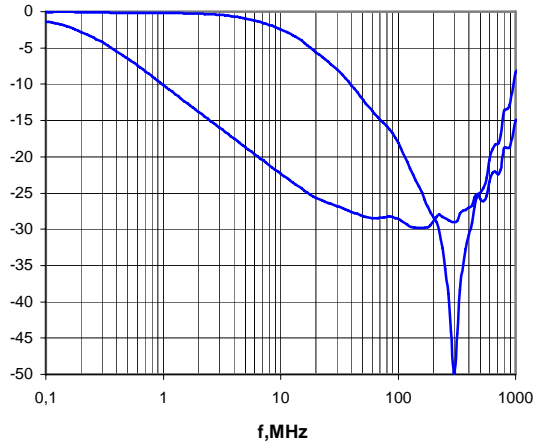

SML3-0022

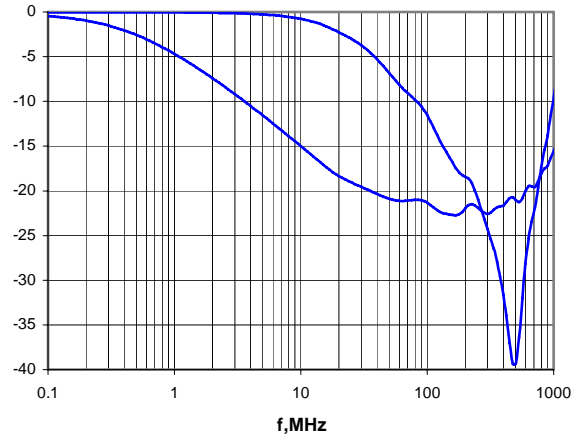

SML3-0033

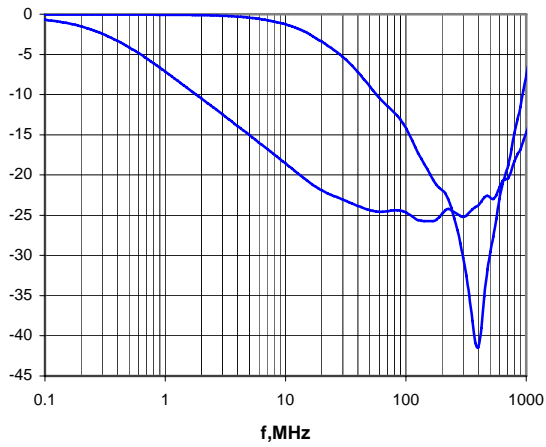

SML3-0051

