

AS18-XXXX

SMT Transponder Coil

- Antenna applications, RFID
- One-piece ferrite core construction
- Compact design, low height
- “Pick & place” surface
- Optional hot-melt adhesive for PWB bonding during solder reflow
- Reflow solder rating: 260°C for 10sec
- Operating temperature: -40°C to +125°C
- RoHS compliant per 2002/95/EC
- Packaging: 3800pcs, 24mm blisterpack
- Custom values available

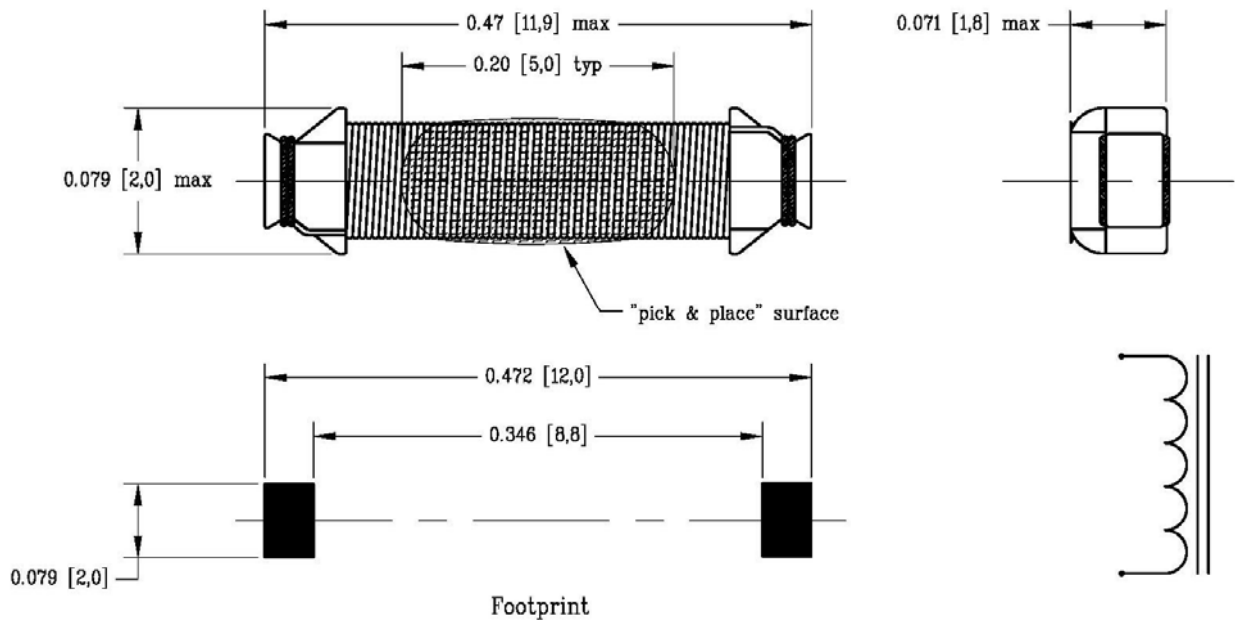

Dash #	“L” ± 10% (mH)	“SRF” min (MHz)	“DCR” max (Ω)	“I” max (mA)
-0130	1.3	1.4	11	50
-0220	2.2	1.0	22	40
-0350	3.5	500 kHz	36	30
-1400	14	250 kHz	144	15