

Orbis Micro-XRF System

The Orbis
Micro-XRF System
Offers Geometry
Designed For
Accurate
Elemental
Analysis When
Results Matter



The Orbis Micro-XRF Analyzer Series



Advanced Elemental Analysis Capability with Higher Sensitivity and Greater Flexibility

The EDAX Orbis Micro-XRF Spectrometer series incorporates analytical technology and advancements in functionality based on over 10 years of industry leading innovation and experience. These bench top instruments are available with either mono-capillary X-ray optics or ultra-high intensity poly-capillary optics, to cover a wide variety of analytical needs. The Orbis is easy to operate, offers a wide range of productivity enhancing features, and is engineered to accommodate various sample types and shapes from different sources. The X-ray sources, optics, and detectors are guaranteed to provide superior analytical results for a wide range of applications. The Orbis Vision Software includes functionality from routine to highly challenging applications.

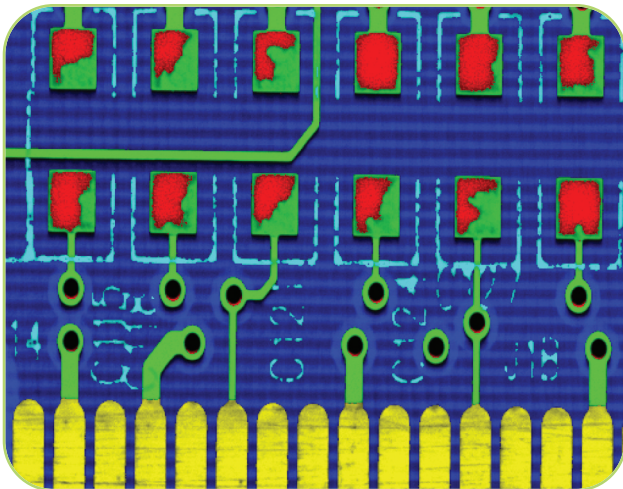

An overlay of a printed circuit board showing five different elements: Br(K) (blue), Au(L) (yellow), Cu(K) (green), Pb(L) (red), and Ti(K) (cyan). The overlay shows the most dominant intensity at a given point.

The Orbis Micro-XRF Analyzer Series

Features Include:

- Non-destructive sample analysis with minimal sample preparation.
 - Analyze “as delivered” samples quickly and easily in low vacuum and even ambient conditions.
- Large vacuum sample chamber with longer working distance.
 - Accommodates a wide range of sample sizes and enables accurate analysis over rougher sample topography with no loss in signal intensity.
- Industry exclusive motorized turret integrating video and X-ray optics provides coaxial X-ray analysis and sample view for more accurate sample positioning without compromise on video quality.
 - Optional 1 mm and 2 mm collimators with X-ray optics available for optimal analytical flexibility.
- Software selectable primary beam filter system with six filters to improve sensitivity and remove spectral artifacts.
 - Eliminates tube characteristic lines, reduces Bremsstrahlung and eliminates Bragg diffraction peaks in targeted spectral regions.
- Comprehensive Orbis Vision Software enables a wide range of qualitative and quantitative analyses with extensive data storage and manipulation capabilities.
 - Provides tools and easy to use solutions for a wide variety of analytical applications in far ranging industries.

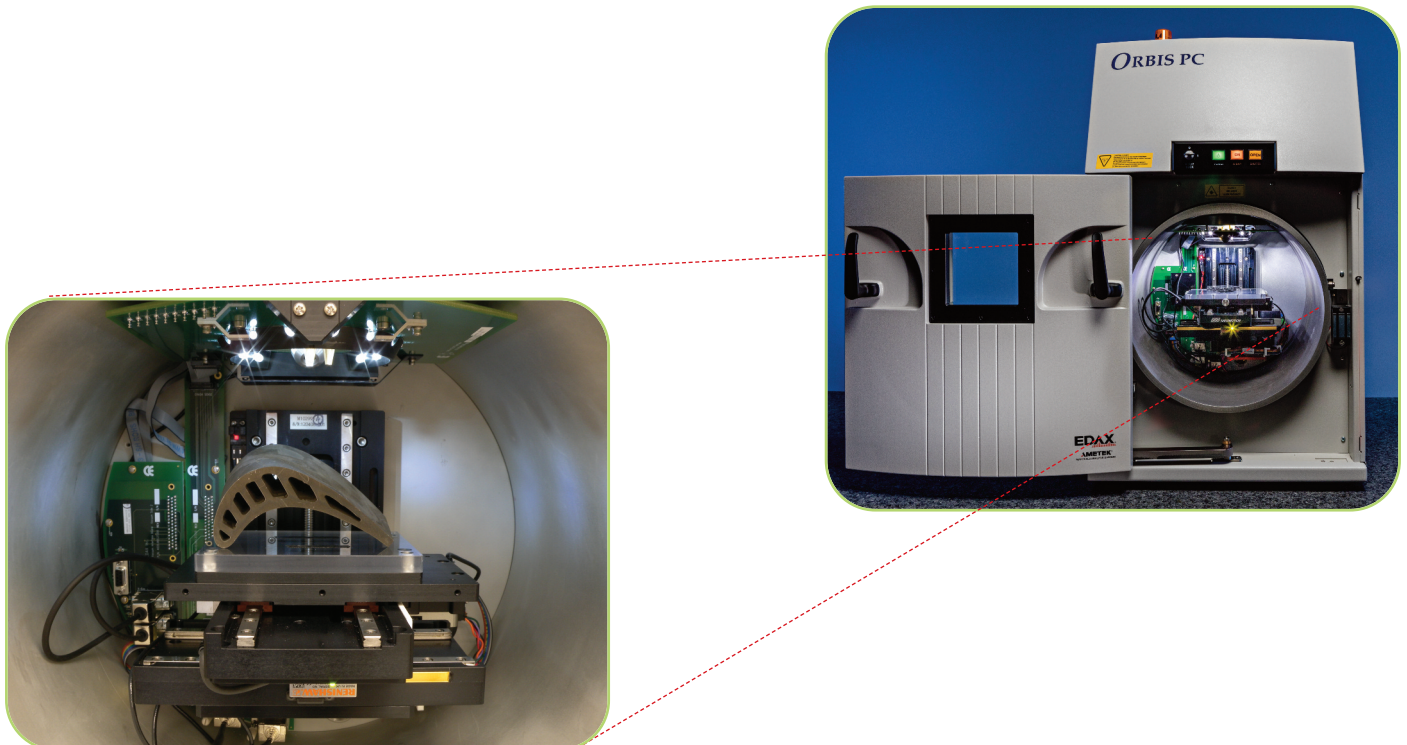
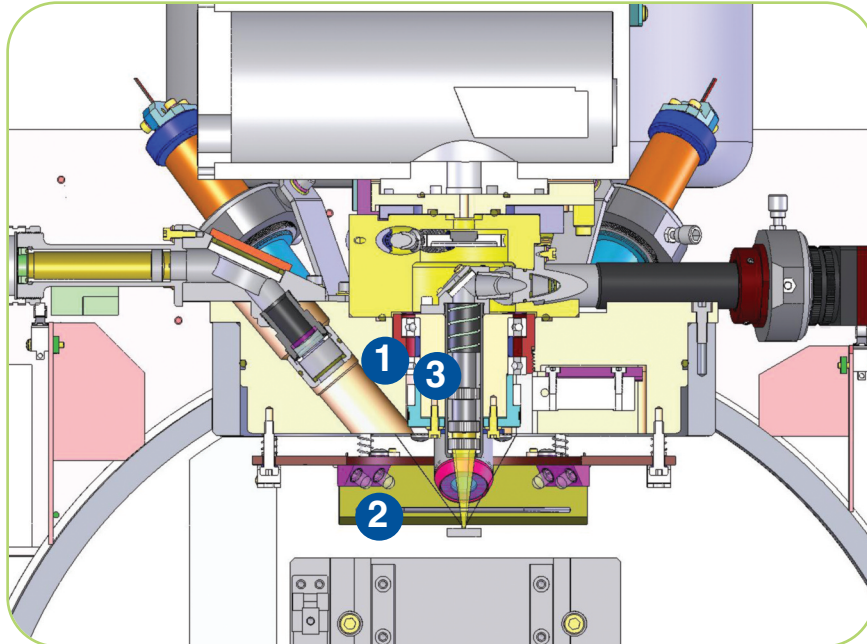

Figure 1. Large vacuum sample chamber accommodates a variety of samples.

Orbis Advanced Functionality By Design

Integrated System Configured to Maximize Analysis Capability for a Wide Range of Sample Types and Sizes



1. Unique Turret Design

- Enables automated selection of up to three different X-ray beam sizes.
- Provides a larger range of analytical spot sizes, allowing the user to select the spot size best suited to specific analysis requirements.
- Offers high magnification video mounted in the turret allowing coaxial video and X-ray paths.

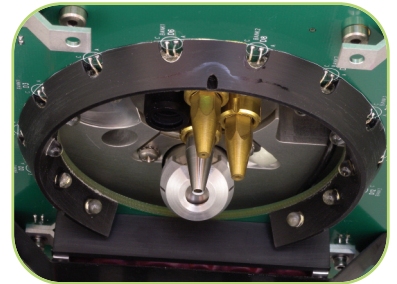

2. Working Distance

Greater working distance between the safety sensor and analytical position prevents loss of signal intensity and sensitivity over varying sample topography and enables simple qualitative and quantitative comparison of spectra.

3. Normal X-ray Beam/Video Geometry

- Allows accurate sample targeting and simple visualization of the X-ray beam trajectory within the coaxial video field of view.
- Eliminates erroneous signal due to obstruction of oblique X-ray beam by sample topography.
- Accommodates a broader range of sample geometries and types without regard to placement of the sample with respect to the X-ray beam path.

*Unobstructed
coaxial video
and X-ray beam*

*Oblique X-ray
beam obstructed*



Orbis Advanced Functionality By Design

Integrated System Configured to Maximize Analysis Capability for a Wide Range of Sample Types and Sizes

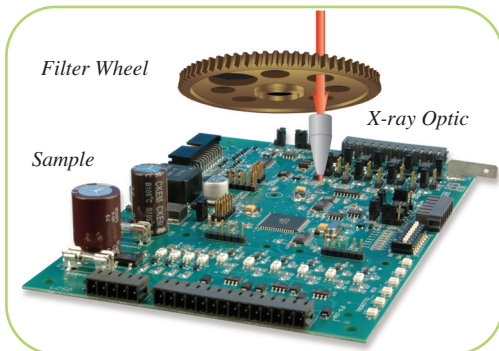
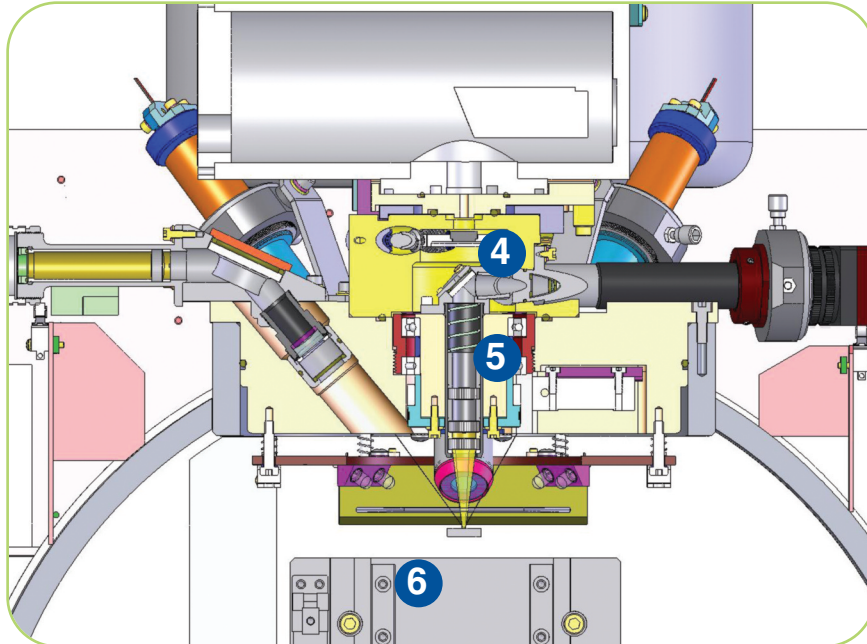

4. Primary Beam Filters

The Orbis allows filters to be implemented with all focusing and collimating X-ray optics to improve detection limits by reduction of Bremsstrahlung scatter, removal of tube characteristic lines, and/or elimination of Bragg diffraction. Filters are positioned between the tube and X-ray optic eliminating unwanted scattering of the X-ray beam onto the sample.

5. X-ray Optics

The Orbis product line can use a variety of collimating and total reflectance X-ray optics. In the standard Orbis Micro-XRF Spectrometer, small spot mono-capillary optics are used to generate a semi-parallel beam. As an option, large spot collimators can be added to the turret to expand the capability of the instrument. Large spot collimators are useful in creating a homogeneous beam over a larger area for analysis of larger sample features and sample volumes (e.g. powders and granulates) or fast mapping to cover large areas where a small X-ray beam is too fine. In the Orbis PC Micro-XRF Spectrometer, an ultra-high intensity poly-capillary optic is used to generate a high sensitivity convergent micro spot X-ray beam. Large spot collimators can also be added in the turret as an option with the poly-capillary.

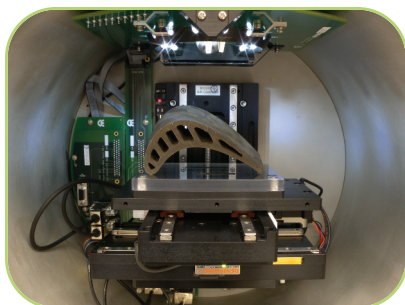

6. Fast XYZ Stage

The Orbis product series uses the latest in piezo-electric stages to drive the X, Y axes for fast sample movements while using a stepper motor on the Z axis to handle more massive samples.

Orbis Micro-XRF Applications

Industrial

Measuring Metal Distribution in Ceramic Catalyst Supports

The Orbis PC mapped the Pd distribution in an extruded Alumina pellet with a reported Pd loading of 5 wt%. The Pd(L) line was used to limit the penetration depth of the analysis on the cross-sectioned surface of the pellet. Standard thermal image scaling shows the Pd to be primarily distributed in a thick shell at the surface of the pellet. Specialized image scaling available in EDAX software reveals a lower level concentration of Pd in the core of the pellet which is obscured in the standard thermal scaling by the high Pd concentrations in the pellet's outer shell. With the optional 2 mm collimator, average metal content can also be determined by measuring the homogenized ceramic pellets.



Video Montage.

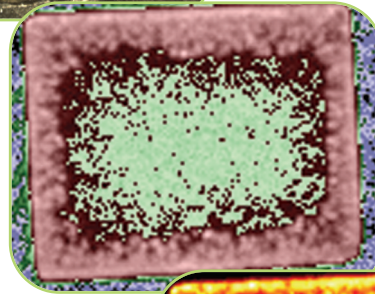

Pd(L) map: 3 log band scaling.

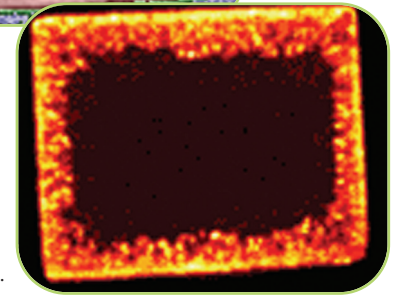

Pd(L) map: Thermal scaling.

Measuring Pb on Printed Circuit Boards for RoHS Compliance

The screening of samples for restricted or banned materials and chemicals is becoming increasingly important. European law, which has quickly spread in various forms globally, restricts the use of Hg, Pb, Cd, hexavalent Cr, and Br, in certain fire retardants in consumer electronics and other electrical appliances. Micro-XRF can be used to determine Hg, Pb, and Cd levels and identify components with significant levels of Cr and Br requiring further definitive testing. In this case, a printed circuit board has been mapped, showing the use of Pb-based solder on the board.

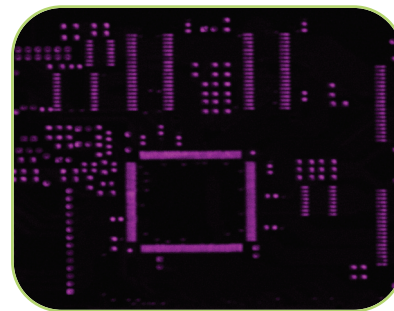

Printed circuit board: Pb(L) X-ray map.

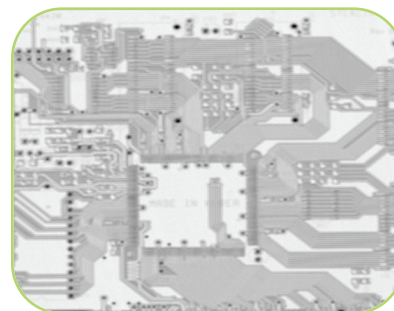

Printed circuit board: Total X-ray spectral count image.

Orbis Micro-XRF Applications

Non-Destructive Testing

Measurement of Cultural Artifacts

To preserve this fading black and white photo, a section of the photo was mapped non-destructively using an Orbis PC to capture an elemental image of the metallic Ag which creates the various shades of gray in the photo.

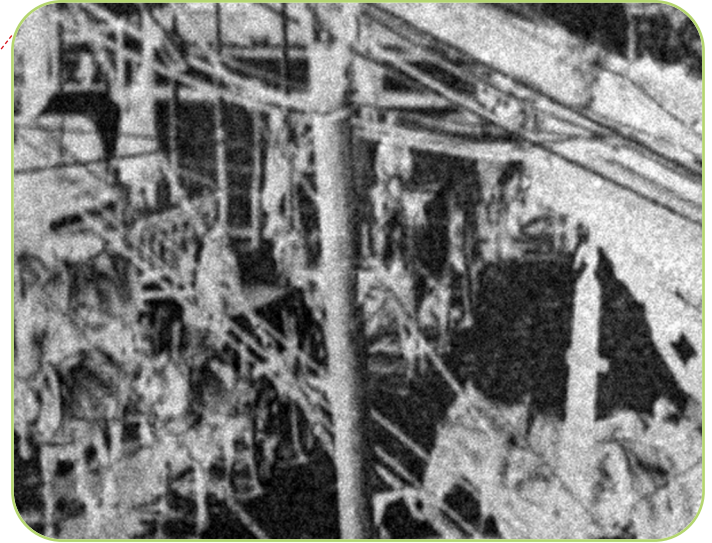

Ag(L) elemental image: This subsection of the image contains two horse-drawn wagons heading from the background to the front left while two horses stand in the right, foreground.

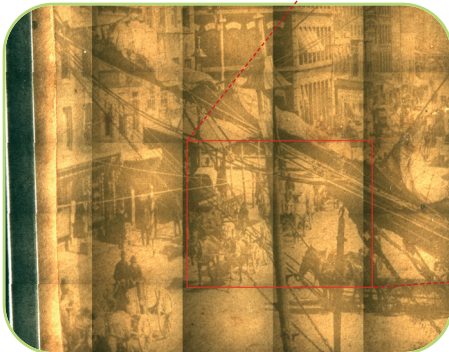

Montage video composite: The photo captures a street scene with horse-drawn wagons and wires hanging over the street.

Meteorite

A large area of this Odessa meteorite section was elementally imaged to elucidate the structure of this extraterrestrial object which impacted the earth some tens of thousands of years ago.

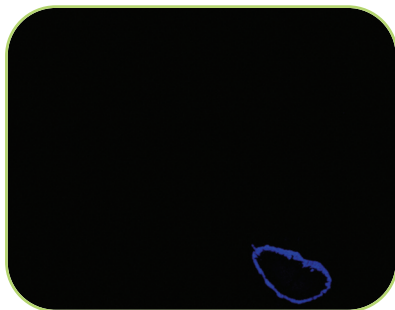

S(K) map: Sulfur in this nodular form is generally associated with Troilite.

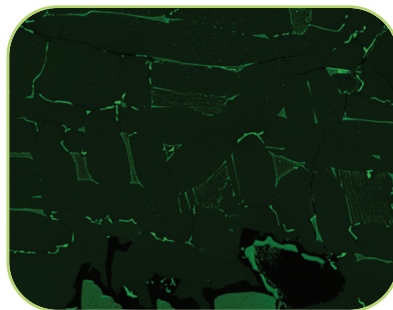

Ni(K) map: Shows Ni rich phases of Taenite and Schreibersite interspersed in the major Kamacite phase.

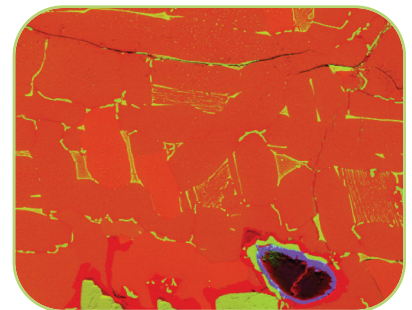

RGB merge: Fe (red), Ni (green), S (blue) showing a nodular Troilite phase (FeS) in purple surrounding a graphite inclusion.

Forensics

Spectral Comparison of Glass Fragments

Micro-XRF enables spectral comparison of glass fragments from the same windshield. The fragments from the inner and outer laminates of the glass have differences, mainly in Fe content.

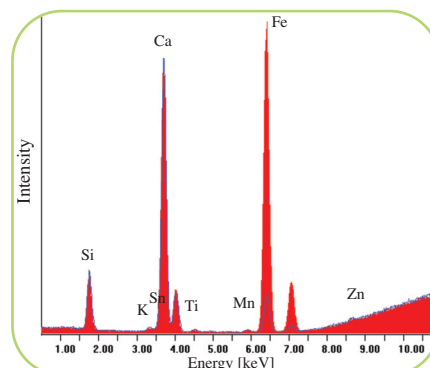

Powerful, Easy to Use Orbis Vision Software Provides Precise Elemental Analysis Capability

- Qualitative and quantitative analysis (with or without standards).
- Automated multi-point analysis.
- Job Mode.
- Spectral imaging and linear scans.
- Alloy identification.
- Layer thickness and composition.

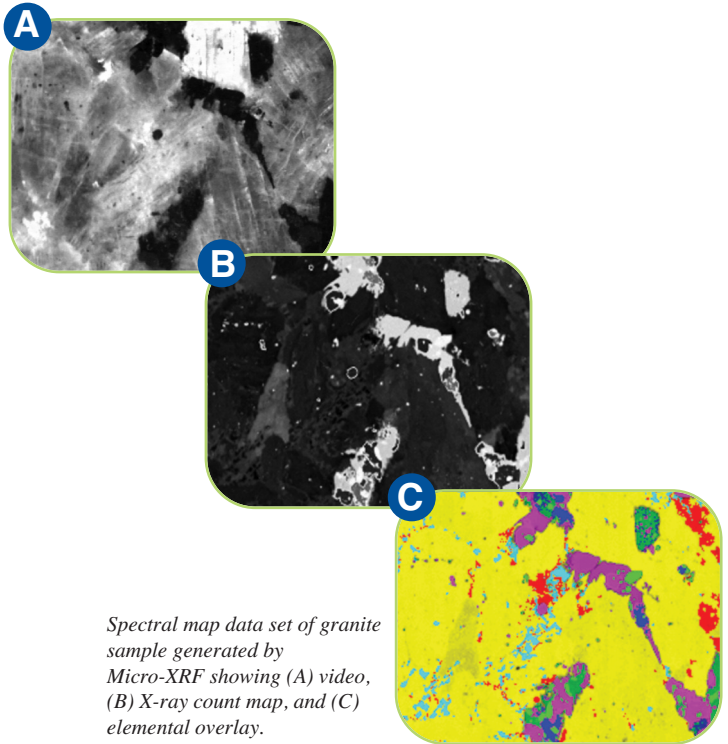

Detector Options:

The Orbis comes standard with an industry-leading 30 mm² Silicon Drift Detector (SDD), which offers LN-free operation and high signal throughput with excellent resolution for state-of-the-art spectral collection. This type of detector is ideal for applications and samples, such as transition metal alloys, which yield high X-ray count rates into the detector. The Orbis is also available with an optional 50 mm² SDD, which offers increased solid angle for more efficient signal collection. This detector option is ideal for both samples which yield high X-ray counts and for applications which yield limited X-ray signal, such as the analysis of ink on paper or polymer fibers.

