

# Grounding Techniques

Ground is taken for granted. We stand on it, we dig into it, we make mud pies out of it. The ground isn't supposed to move. We don't have to think about it; it just is. When it comes to grounding a circuit, we assume that our connections are as solid as the turf below our scuffed shoes. Many times, this is a reasonable assumption-but not always. How do we know when there is a problem with a circuit's ground? What practices will ensure we construct a good ground?

No longer to be taken for granted, we define ground in ideal and real situations. Ground configurations and printed circuit board (PCB) examples will be presented.

## Ground Terminology

Many nodes are called "ground". There are floating grounds, virtual grounds, AC grounds and earth grounds. For clarity, let's look at the difference.

- Floating grounds are reference points within an isolated system. They are a reference point and only equal to 0 volts through luck.
- Virtual grounds exist in a negative feedback circuit at the inverting terminal of an op amp. When the noninverting input is held at zero volts, the feedback (in a stable circuit) will cause the inverting terminal to match. The value is only held by feedback and is not a stable return for other circuit currents.
- AC grounds are nodes with low impedance DC values. That DC voltage is stable with small circuit perturbations. Since the node has a DC value, it is not useful as a proper ground. However, since it is stable, it is useful as a reference point. AC (or small-signal) analysis considers these points to be unchanging, thus like a ground.
- Earth ground is exactly what the words suggest. Every house has a copper pole sunk into the ground to deplete surplus currents. Without the presence of a buried battery, the top layer of turf is fairly homogenous. A house down the street from yours might have a difference in ground voltage of a hundred microvolts. This is the type of ground we are going to discuss.

**TABLE 1. COMPARISON OF VARIOUS TYPES OF ELECTRICAL GROUNDS**

GROUND TERMINOLOGY	DEFINITION	CONNECTED TO EARTH GROUND	EXAMPLE
Floating Ground	Local reference potential	NO	Medical systems to protect patient
Virtual Ground	Node held at or near ground potential by feedback	NO	Negative input terminal on Inverting Op Amp
AC Ground	Node held at a constant DC potential	NO	V <sub>SUPPLY</sub> , Bias voltage, Bandgap voltage
Reference/Earth Ground	System ground	YES	DIRECT CONNECTION to earth ground

## What is Ground?

I asked a handful of fellow engineers to define "ground". A chorus of answers responded "Zero volts" or "Zero reference." A more extensive definition can be found on Answers.com<sup>TM</sup> [1], "a large conducting body (as the earth) used as a common return for an electric current and as an arbitrary zero of potential." This definition is particularly helpful because it refers to the role of ground in terms of voltage AND current.

To explore this dual role, let's look at an extremely simple circuit, Figure 1a. This circuit could represent a plethora of different systems—a flashlight, a coffee maker, or even an iPod. Figure 1b represents those circuits just as well. Of course, we don't typically think of ungrounding a circuit to turn it off, we think of disconnecting the power. The truth is, they are equally effective. The load and the switch are in series, so the order is irrelevant. An open switch stops the flow of current; zero current through the load means zero power in the load. (In practice, the circuit in Figure 1a is more common than Figure 1b for a practical reason—it is more likely that the system could accidentally become connected to ground (a loose wire to the chassis, for instance) causing unwanted power in the load than to accidentally become connected to the power supply.) The principle, however, is useful.

Those lines representing the connection between the source and load could be of a wide variety of lengths. They could be a few inches long, as in a household appliance, or they could be miles long, as in the power grid. In small systems, the assumption of a lossless wire is reasonable. As system sizes increase, the connections (wires, board traces, and interfaces) can no longer be considered lossless. An extreme example is the lines from the power company. Between the repeaters, the power is transmitted with high voltage (hundreds of kilovolts) and minimal current to negate losses caused by series resistance.

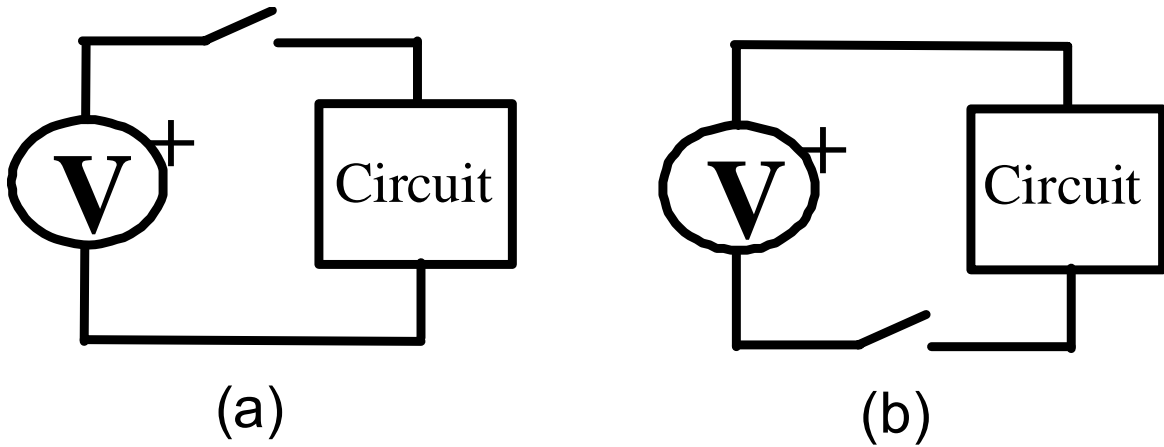

FIGURE 1. SIMPLE CIRCUIT. SWITCH CAN STOP THE FLOW OF CURRENT TO THE CIRCUIT OR AWAY

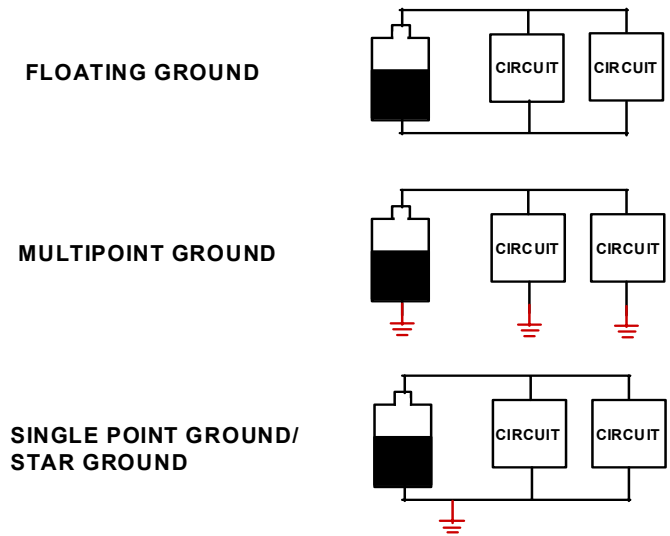

FIGURE 2. GROUNDING TOPOLOGIES: FLOATING GROUND, MUTLIPOINTGROUND, SINGLE-POINT GROUND

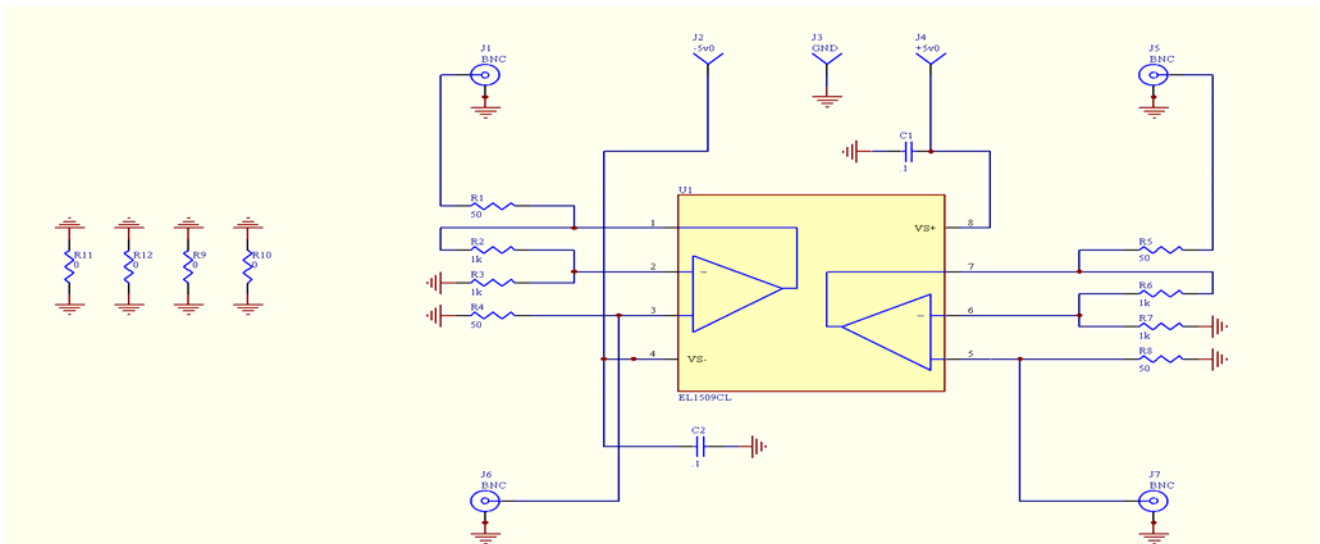

FIGURE 3. TEST CIRCUIT USED IN LAYOUTS FOR FIGURES 4-6

# Application Note 1681

## PCB Examples

A dual op amp is chosen as the layout example. For clarity, a single layer of copper is used for all routing (this is not the best choice for speed, isolation, coupling, etc.). Figure 3 shows the complete schematic used for each of the PCB examples.

Capacitors C1 and C2 are included to bypass the supply for the dual op amp package. Resistors R1, R4, R5, and R8 are matching resistors for terminating cables, assuming we are operating in a 50Ω environment. Resistors R2, R3, R6, and R7 set the amplifiers in a non-inverting configuration with a gain of 2. And lastly, because a single layer is used and a bit of wire-jumping is necessary, a few zero ohm resistors (R9-R12) have been included as well.

Figure 4 shows the first attempt to layout our circuit. The ground connection travels right down the center, providing a spine to our bilaterally symmetric creation. Sadly, though, both the positive and negative supplies travel in a large loop around both sides of the device. It's great that the layout is symmetric; it's not so great that the power lines loop around the board. These long, thin traces will act as antennas, picking up as much of the local RF noise as they can. In addition, the traces may have measurable IR drop in them-another downside.

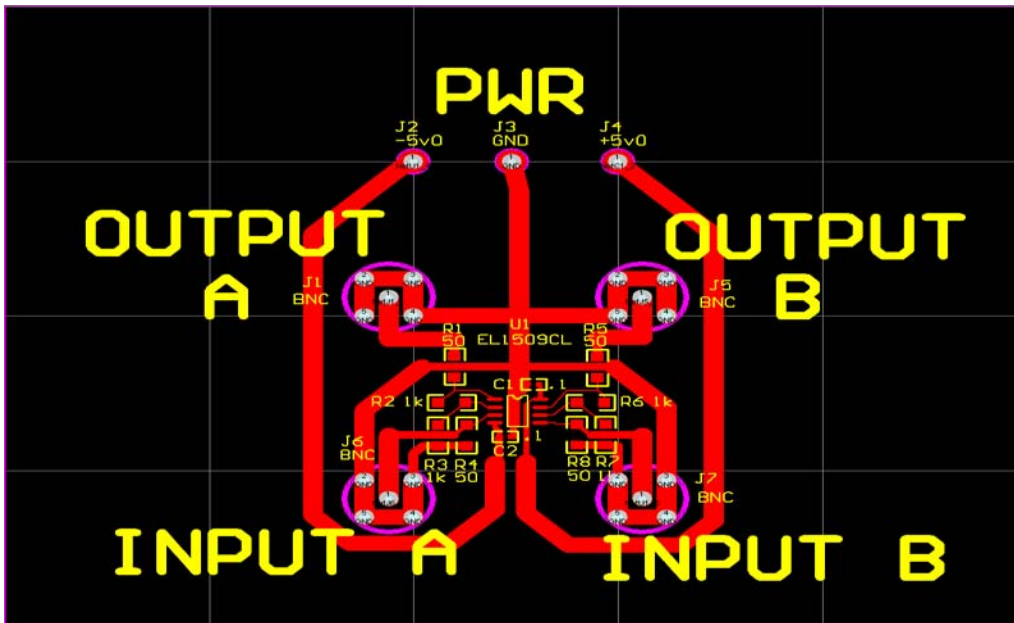

FIGURE 4. WIRED GROUND LAYOUT

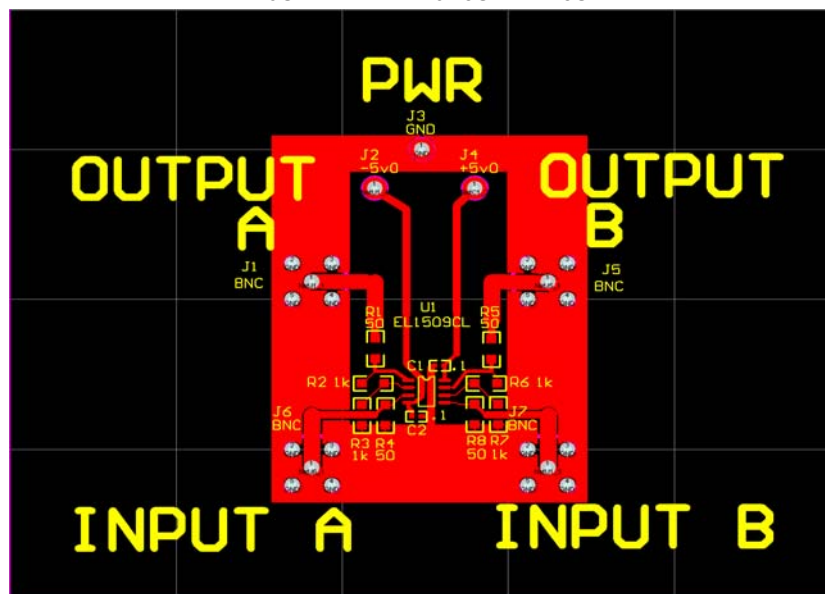

FIGURE 5. OUTER GROUND PLANE

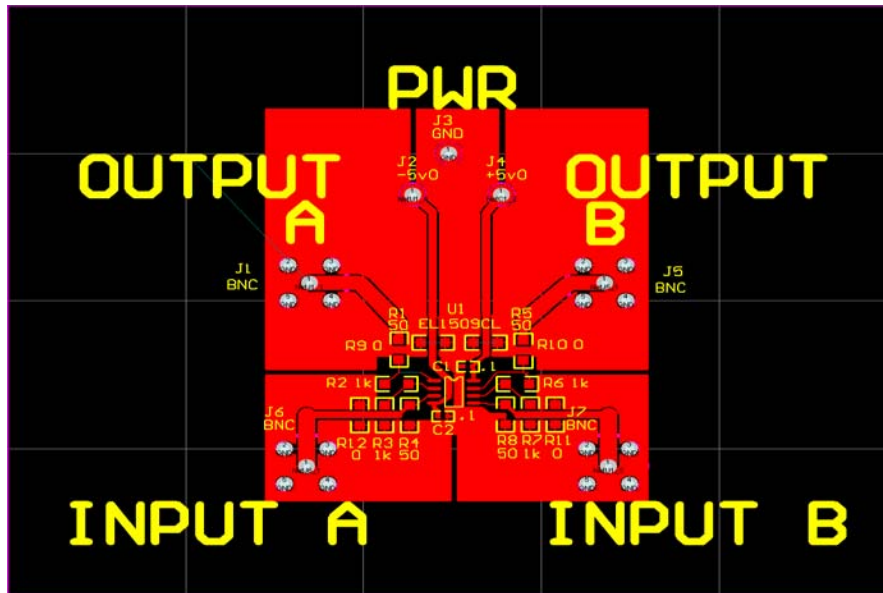

FIGURE 6. SPLIT/STAR GROUND PLANE

The next attempt at layout is shown in Figure 5. In a single-layer board, this is a close approximation to having a "ground plane". This time the ground loops around the outside of the board. A connection to ground is made every time it is needed. This could be considered a multi-point ground. Instead of a thin trace, though, the ground connection is wide (considerably lower impedance). However, any noise that couples into either power supply will still be radiated from the area of the loop created by the power trace and the ground connection.

Figure 6 shows our best layout. Ground once again forms a plane around the device, but there are 5 slices keeping it from being continuous. Notice that each of the ground planes connects to the others, but only at one place. This is an example of a single-point or star ground. Currents cannot travel haphazardly throughout the ground plane; they are steered through specific paths we create and control. This type of set-up will minimize any antenna characteristics, both emitting and receiving.

These examples offer a bit of insight into the types of grounding schemes and how they appear on a printed circuit board. The best advice is to "follow the currents":

- The longer a current has to travel, the more trouble it can cause. It is the best policy to keep wide, low-impedance ground connections as close to the devices as possible.
- Multiple currents can interact. If multiple loops overlap, break up the ground connection to minimize coupling.
- Don't forget the return currents! Every current leaving a node must return via some path. If the forward and return paths are very close (enclosed in a small area) the external fields cancel. If not, you have an antenna.

## References

- [1] Answers.com. October 20, 2011.  
<<http://www.answers.com/topic/ground>>.

Intersil Corporation reserves the right to make changes in circuit design, software and/or specifications at any time without notice. Accordingly, the reader is cautioned to verify that the Application Note or Technical Brief is current before proceeding.

For information regarding Intersil Corporation and its products, see [www.intersil.com](http://www.intersil.com)