

Atlantic 6



Atlantic 6 is youngest member in Atlantic family. It is designed for industrial micromachining applications as a reliable, compact and cost effective solution. Hybrid fiber and DPSS technologies implemented in this model make it also very energetically efficient, which enables air cooling solution for laser head. No water is used inside laser, which means you shouldn't worry about unexpected leakage, regular water replacement or possible chiller failure. Laser head generates only around 150 W of heat, so it required quite simple heat management solutions for system integrators. Laser don't require a chiller or big heat exchanger, so all control and power supply electronics is fit into standard 3U 19-inch rack.

Hybrid technology enables new pulse control features, which are not preset in earlier Atlantic series lasers. Atlantic 6 can provide burst of pulses spaced only 25 ns in time, so called seeder burst mode. It is very useful in material processing applications, because in some cases it allows to

increase process efficiency or at least provides additional variable parameter for process optimization. Atlantic 6 has very broad range of accessible pulse repetition ranges, from single pulse to 5 MHz. Sophisticated pulse picker provides any required sequence of pulses with high contrasts and perfect pulse to pulse parameters stability. Laser offers external synchronization with very low jitter, in range of 20 ps, which enables good synchronization with very fast scanning systems, like polygon scanner.

Each Atlantic series laser pass very strict quality assurance procedure. Every single unit is checked for vibrations resistance, tested at different environment temperature and humidity conditions, treated by extreme temperatures (up to 70 °C). Before shipment multiple external and internal laser parameters are measured and checked with technical requirements. This costs us time and resources but we believe this is necessary to guaranty unprecedented laser quality and

Industrial Compact Air Cooled Picosecond Laser

FEATURES

- ▶ **6 W at 1064 nm** output power
- ▶ Up to **5 MHz** repetition rate
- ▶ Up to **25 μJ** pulse energy
- ▶ Short pulse duration **10 ps**
- ▶ Excellent beam quality $M^2 < 1.3$
- ▶ Air cooling (dry laser head)
- ▶ Seeder burst mode, pulse on demand
- ▶ Smart triggering for synchronous operation with polygon scanner
- ▶ Compact, sealed and rugged design
- ▶ Low maintenance
- ▶ Single-phase powering

APPLICATIONS

- ▶ Cold marking
- ▶ Sapphire dicing
- ▶ Heat sensitive material processing
- ▶ Medical stents fabrication
- ▶ CIGS scribing
- ▶ Patterning, texturing, structuring

trouble free operation at customer side. Our engineers are always ready to collaborate with system integrators providing valuable advices or/and small laser optimizations according to integrators needs.

SPECIFICATIONS ¹⁾

	Atlantic 6-1064	Atlantic 6-532	Atlantic 6-355
GENERAL SPECIFICATIONS			
Wavelength	1064 nm	532 nm ²⁾	355 nm ²⁾
Repetition rate	100 kHz to 5000 kHz ³⁾		
Average output power	> 6 W at 5000 kHz ⁴⁾	> 1.2 W at 100 kHz	> 0.8 W at 100 kHz
Pulse energy at 100 kHz	> 25 µJ ⁵⁾	> 12 µJ	> 8 µJ
Pulse energy contrast	> 100 : 1	> 500 : 1	> 1000 : 1
Power fluctuations over 8 h (Std. dev.)	< 2.0 %	< 2.5 %	< 3.0 %
Pulse energy stability (Std. dev.)	< 0.8 %	< 1.5 %	< 1.5 %
Pulse duration (FWHM) ³⁾	< 10 ps		
Spatial mode	TEM ₀₀		
Pulse output control	frequency divider (down to single shot), arbitrary pulse selection, seeder burst mode, power attenuation		
Polarization	linear, vertical 100 : 1		
M ²	< 1.3		
Beam divergence	< 2.0 mRad	< 1.5 mRad	< 1.5 mRad
Beam pointing stability	< 50 µRad		
Beam diameter (1/e ²)	1.8 ± 0.2 mm	1.1 ± 0.2 mm	1.0 ± 0.2 mm
Triggering mode	internal / external		
Control	keypad / USB / RS232 / LAN / WLAN		
OPERATING REQUIREMENTS			
Mains requirements	100...240 V AC, 5A, single phase 47...63 Hz		
Power	< 1.0 kW		
Operating ambient temperature	18–27 °C		
Relative humidity	10–80 % (non-condensing)		
Air contamination level	ISO 9 (room air) or better		
PHYSICAL CHARACTERISTICS			
Cooling	air		
Laser head size (W × H × L)	360 × 120 × 350 mm	592 × 156 × 364 mm	
Power supply unit size (W × H × L)	471 × 153 × 512 mm		
Umbilical length	3 m		
CLASSIFICATION			
Classification according EN60825-1	CLASS 4 laser product		

¹⁾ Due to continuous improvement, all specifications are subject to change without notice. Parameters marked typical are not specifications. They are indications of typical performance and will vary with each unit we manufacture. Unless stated otherwise, all specifications are measured at 1064 nm.

²⁾ Fundamental wavelength and lower harmonics are also available with full specifications. Automatically switched outputs.

³⁾ Pulse repetition rate can be factory pre-set to single requested frequency or tunable in all specified range. Lower pulse repetition rates are available using pulse gating system (included in standard configuration).

⁴⁾ See typical power curve for other pulse repetition rates.

⁵⁾ See typical power curve for other pulse repetition rates.



LASER HEAD IMAGE

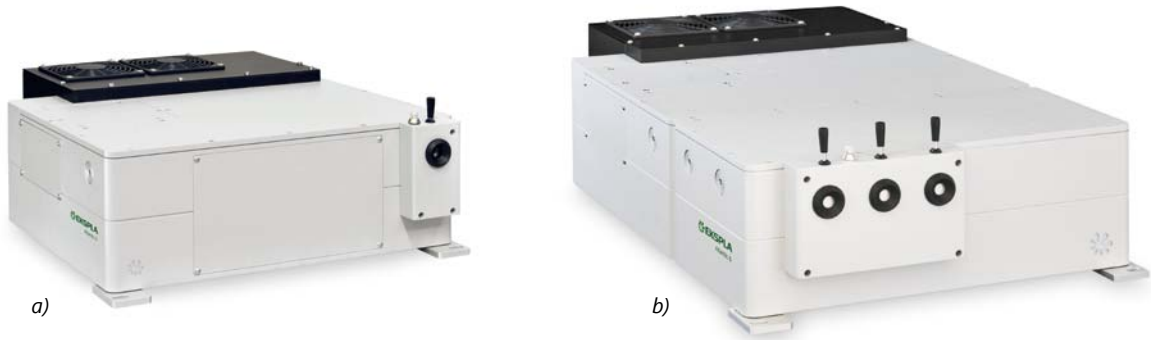

Typical views of Atlantic 6 laser heads: a) Atlantic 6-1064, b) Atlantic 6-532 and Atlantic 6-355

PERFORMANCE

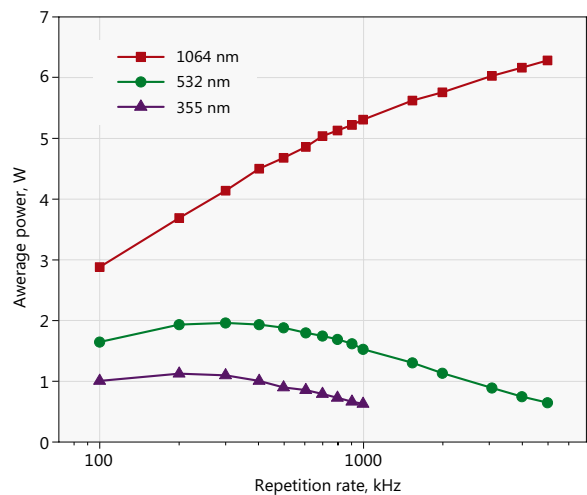
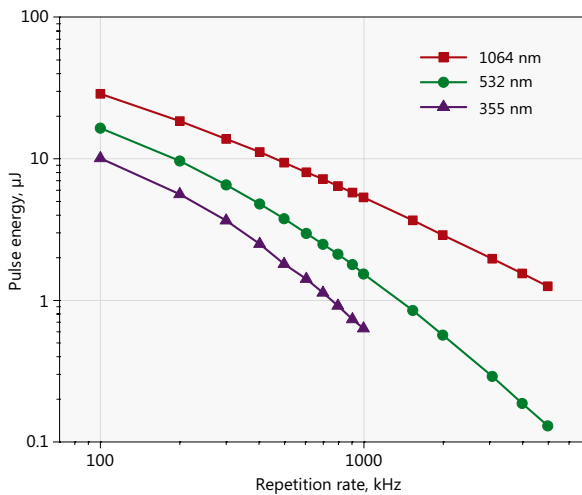

POWER SUPPLY OUTLINE DRAWINGS

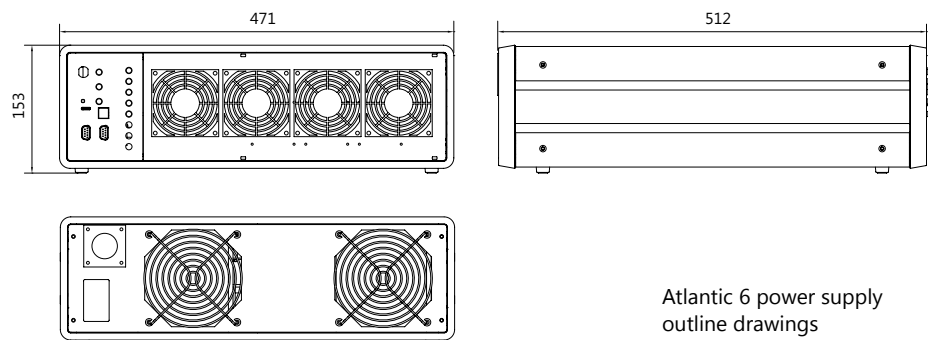

Atlantic 6 power supply outline drawings

LASER HEAD OUTLINE DRAWINGS

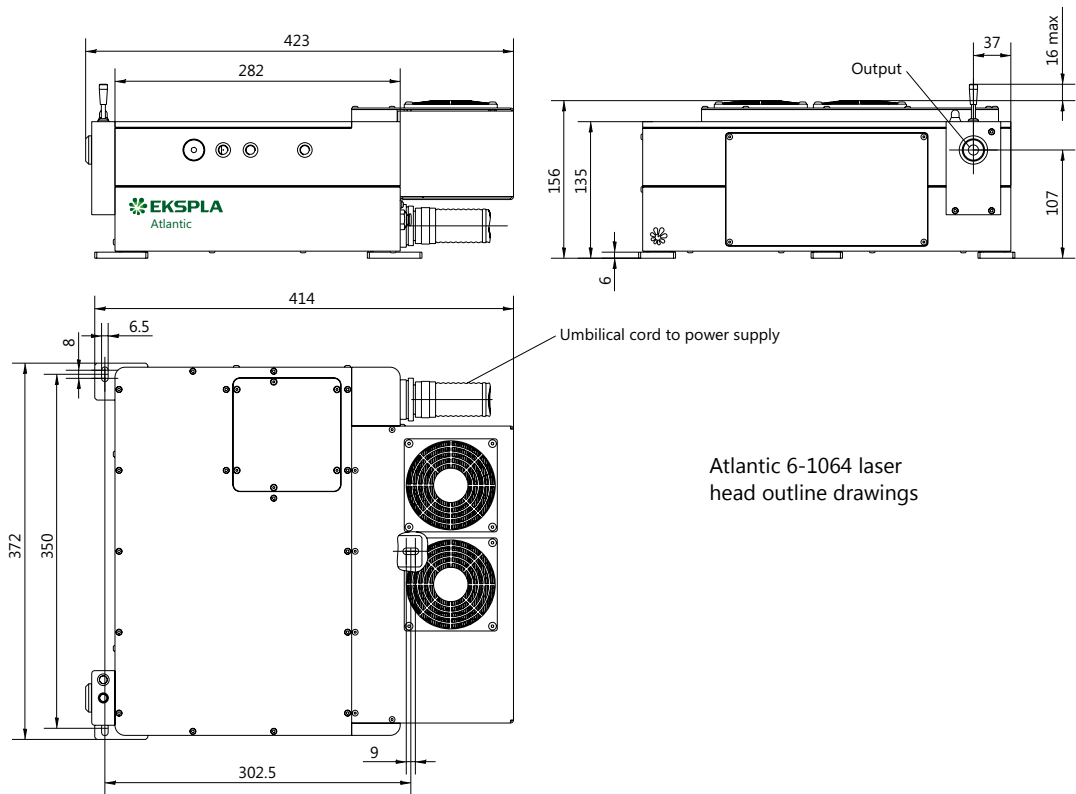

Atlantic 6-1064 laser head outline drawings

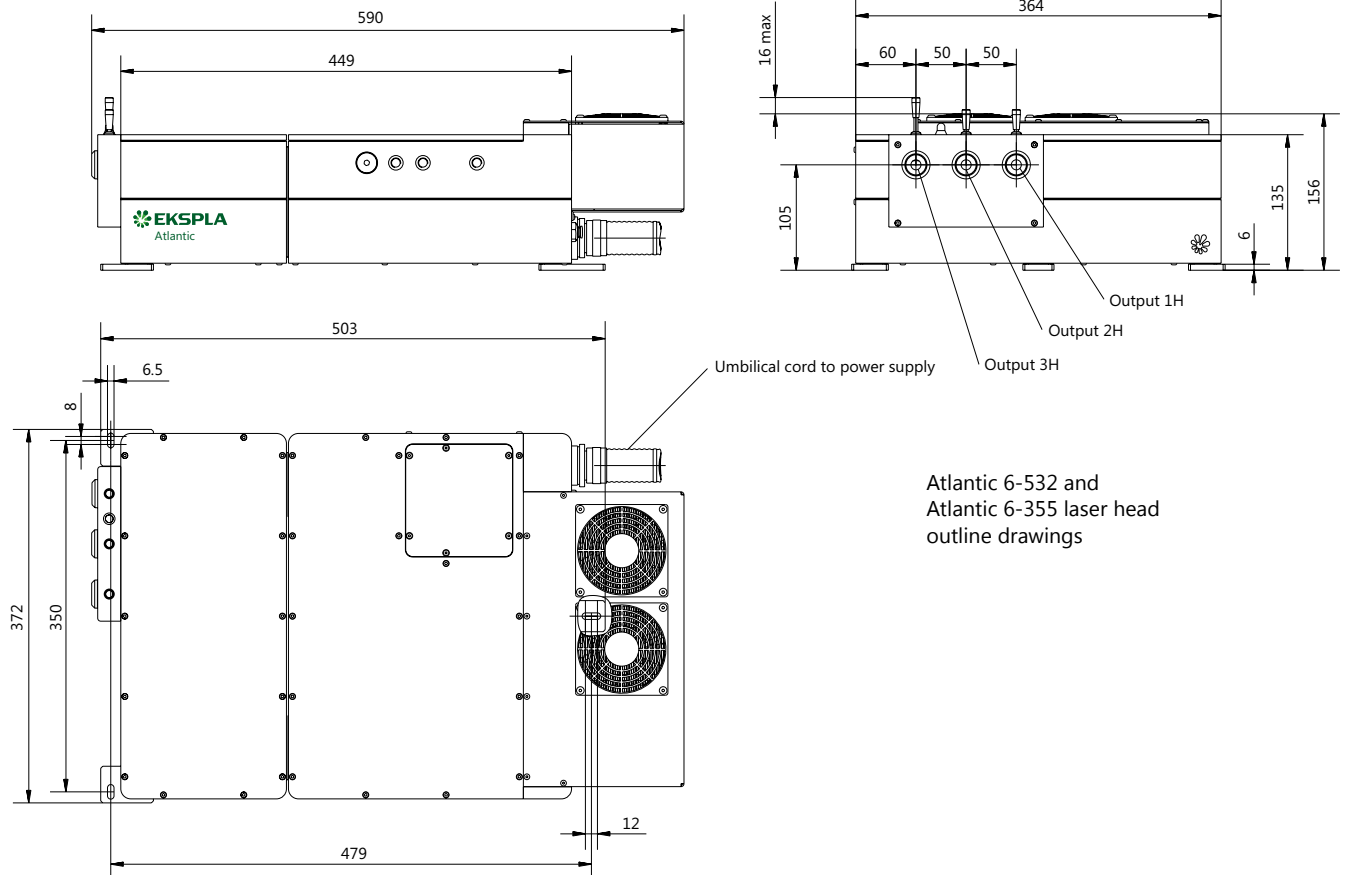

Atlantic 6-532 and Atlantic 6-355 laser head outline drawings