

# Adult Teakwood Folding Shower Seats

## "L" shape with Legs (RH/LH)

Configuration:  
**60/61 Series**  
with legs

### Application Use:

Architectural

Commercial

Institutional

Residential

### Specifications

Folding shower seat manufactured by ELCOMA from 1" (25mm) diameter, 18 gauge and 1.25" x 1.25" (32mm x 32mm), 16 gauge, type 304 stainless steel tubing with #4 satin finish. Wall mount brackets shall be 12 gauge type 304 stainless steel. Slatted Teakwood seat shall be 1/2" (13mm) thick and shall be mildew resistant. Shower Seat shall comply with all applicable federal, provincial and local building and safety codes.

Natural Teakwood finish (yellowish / brownish wood color)

**\*\* RIGHT HAND SHOWN , LEFT HAND OPPOSITE ORIENTATION \*\***



### Custom sizes are available to suit special requirements.

26" x 21"	(660mm x 533mm)	Teakwood	Model # 60-TK26WLEG
28" x 21"	(711mm x 533mm)	Teakwood	Model # 60-TK28WLEG
30" x 21"	(762mm x 533mm)	Teakwood	Model # 60-TK30WLEG
32" x 21"	(812mm x 533mm)	Teakwood	Model # 60-TK32WLEG
34.5" x 21"	(876mm x 533mm)	Teakwood	Model # 60-TK345WLEG

Model #61 - (for left hand)

Elcoma Shower Seats have been designed and tested to withstand 600lbs. (272kgs) of load when properly installed.\* This exceeds HUD, FHA, VA, ADA, ANSI and other federal, provincial, and local codes.

\*Shower seats can only be as strong as what they are mounted to.

It is imperative when installing any shower seat to consult with a qualified contractor to insure you have sufficient backing.

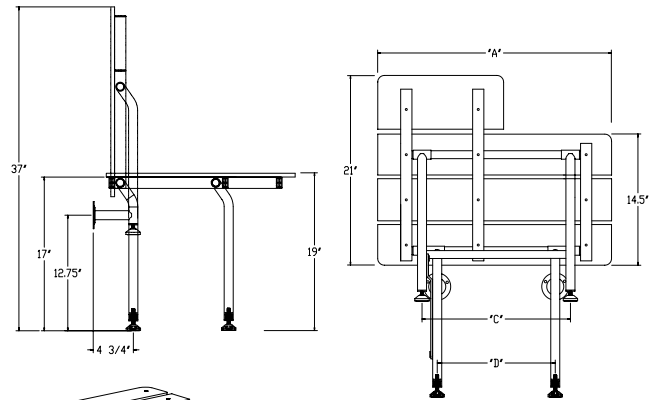

60= Right Hand (shown)  
61= Left Hand (opposite)

SEAT SIZE 'A'	26	28	30	32	34.5
LEG WIDTH 'C'	16.4	18.4	20.4	22.4	24.9
LEG WIDTH 'D'	13.1	15.1	17.1	19.1	21.6

