

# Adult Teakwood Folding Shower Seats

## "L" shape (RH/LH)

Configuration:  
**60/61 Series**  
Teakwood

### Application Use:



### Specifications

Folding shower seat manufactured by ELCOMA from 1" (25mm) diameter, 18 gauge and 1.25" x 1.25" (32mm x 32mm), 16 gauge, type 304 stainless steel tubing with #4 satin finish. Wall mount brackets shall be 12 gauge type 304 stainless steel. Slatted Teakwood seat shall be 1/2" (13mm) thick and shall be mildew resistant. Shower Seat shall comply with all applicable federal, provincial and local building and safety codes.

Natural Teakwood finish (yellowish / brownish wood color)

**\*\* LEFT HAND SHOWN , RIGHT HAND OPPOSITE ORIENTATION \*\***



### Custom sizes are available to suit special requirements.

26" x 21" (660mm x 533mm)	Teakwood	Model # 61-TK26
28" x 21" (711mm x 533mm)	Teakwood	Model # 61-TK28
30" x 21" (762mm x 533mm)	Teakwood	Model # 61-TK30
32" x 21" (812mm x 533mm)	Teakwood	Model # 61-TK32
34.5" x 21" (876mm x 533mm)	Teakwood	Model # 61-TK345

*Model #60 - (for right hand)*

Elcoma Shower Seats have been designed and tested to withstand 400lbs. (182kgs) of load when properly installed.\* This exceeds HUD, FHA, VA, ADA, ANSI and other federal, provincial, and local codes. \*Shower seats can only be as strong as what they are mounted to. It is imperative when installing any shower seat to consult with a qualified contractor to insure you have sufficient backing.

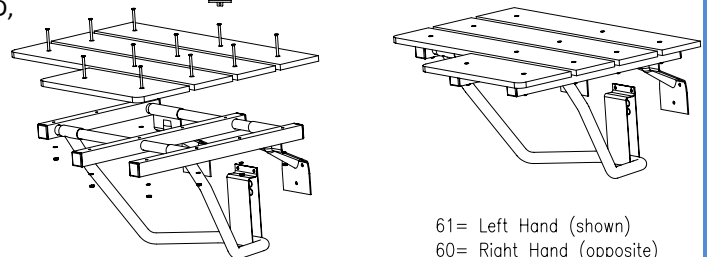
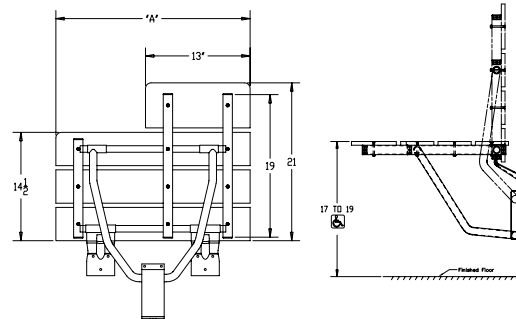

61= Left Hand (shown)  
60= Right Hand (opposite)