

ELM93xxxB CMOS High efficiency PFM step-up DC/DC converter

<http://www.elm-tech.com>

■General description

ELM93xxxB is CMOS step-up DC/DC converter which consists of reference voltage source, error amplifier, oscillation circuit, start-up circuit, PFM control circuit, switching transistor and output voltage setting resistor. For external parts, coil, diode and capacitor are possible choices; with external parts, ELM93 series is able to acquire constant output voltage higher than input voltage. The standard output voltages are 2.7V, 3.0V, and 3.3V; ELM93 series can also be designed as semi-custom IC within the range of 1.8V to 3.8V by 0.1V step.

■Features

- Output voltage range : 1.8V to 3.8V (by 0.1V)
- Low voltage operation : $V_{in} \geq 0.9V$ ($R_L = 30k\Omega$)
- Low power operation : Typ. $24\mu W$ (ELM9330xB)
- High efficiency : Typ. 85%
- High output voltage accuracy : $\pm 2.5\%$
- Output current (e.g.) : 40mA ($V_{in} = 1.5V$, $V_{out} = 3.0V$)
- Package : SOT-89, SOT-23

■Application

- Constant voltage source for battery-operated devices
- Constant voltage source for cameras
- Portable communications equipments
- Local regulator

■Maximum absolute ratings

Parameter	Symbol	Limit	Unit
Apply voltage to LX pin	V_{lx}	5	V
Apply voltage to VOUT pin	V_{out}	4	V
Output current of LX pin	I_{lx}	200	mA
Power dissipation	P_d	500 (SOT-89)	mW
		250 (SOT-23)	
Operating temperature	T_{op}	-40 to +85	$^{\circ}C$
Storage temperature	T_{stg}	-55 to +125	$^{\circ}C$

■Selection guide

ELM93xxxB-x

Symbol		
a, b	Output voltage	e.g. : 27: $V_{out} = 2.7V$ 30: $V_{out} = 3.0V$ 33: $V_{out} = 3.3V$
c	Package	A: SOT-89 B: SOT-23
d	Product version	B
e	Taping direction	S: Refer to PKG file N: Refer to PKG file

ELM93 x x x B - x
 $\uparrow \uparrow \uparrow \uparrow \uparrow$
 a b c d e

ELM93xxxB CMOS High efficiency PFM step-up DC/DC converter

<http://www.elm-tech.com>

■ Pin configuration

SOT-89(TOP VIEW)

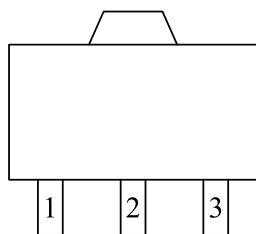

Pin No.	Pin name
1	VSS
2	VOU
3	LX

SOT-23(TOP VIEW)

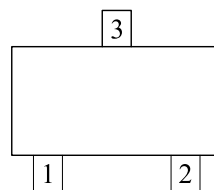

Pin No.	Pin name
1	VSS
2	LX
3	VOUT

■ Standard circuit

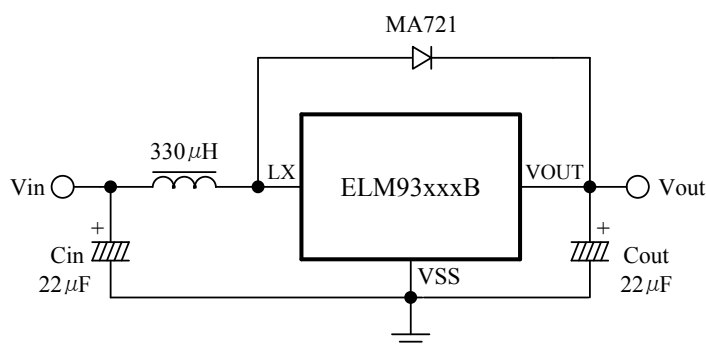

Cin : The circuit can operate without Cin, but adding Cin to the circuit can lower the feedback noise to the Input; this method is also effective in improving efficiency because input voltage drop during switching can be eased. Under the condition of $I_{out} \leq 10\text{mA}$, please connect tantalum capacitor of $10\mu\text{F}$ to $47\mu\text{F}$ to a coil as close as possible.

■ Block diagram

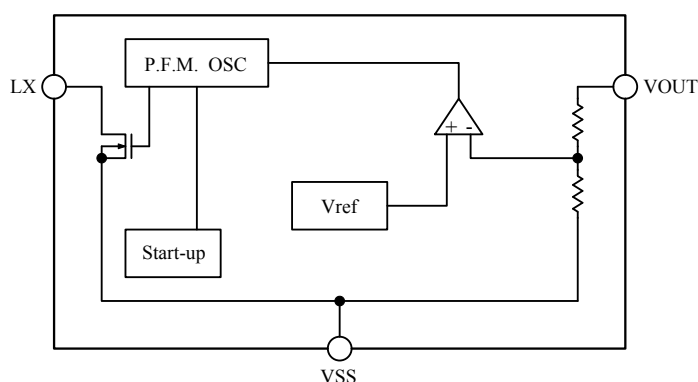

ELM93xxxB CMOS High efficiency PFM step-up DC/DC converter

<http://www.elm-tech.com>

■Electrical characteristics

Vout=2.7V(ELM9327xB)

L=330μH, Cin=Cout=22μF, D=MA721, Vss=0V, Top=25°C

Parameter	Symbol	Condition	Min.	Typ.	Max.	Unit
Starting voltage	Vst	RL=30kΩ			0.9	V
Holding voltage	Vhold	Iout=1mA			0.7	V
Current consumption	Iss	Iout=100μA, Vin=1.5V		8.0	16.0	μA
Output voltage	Vout	Iout=1mA, Vin=1.5V	2.63	2.70	2.77	V
Output current of LX pin	Ilx	Vout=2.6V, Vlx=0.4V	60			mA
Leakage current of LX pin	Ilxl	Vout=3.5V, Vlx=3.5V			1.0	μA
Oscillating frequency	Fosc	Vout=2.6V	80	100	120	kHz
Duty ratio	Duty	Vout=2.6V, Switch"ON"	65	75	85	%

Vout=3.0V(ELM9330xB)

L=330μH, Cin=Cout=22μF, D=MA721, Vss=0V, Top=25°C

Parameter	Symbol	Condition	Min.	Typ.	Max.	Unit
Starting voltage	Vst	RL=30kΩ			0.9	V
Holding voltage	Vhold	Iout=1mA			0.7	V
Current consumption	Iss	Iout=100μA, Vin=1.5V		8.0	16.0	μA
Output voltage	Vout	Iout=1mA, Vin=1.5V	2.92	3.00	3.08	V
Output current of LX pin	Ilx	Vout=2.9V, Vlx=0.4V	70			mA
Leakage current of LX pin	Ilxl	Vout=3.5V, Vlx=3.5V			1.0	μA
Oscillating frequency	Fosc	Vout=2.9V	80	100	120	kHz
Duty ratio	Duty	Vout=2.9V, Switch"ON"	65	75	85	%

Vout=3.3V(ELM9333xB)

L=330μH, Cin=Cout=22μF, D=MA721, Vss=0V, Top=25°C

Parameter	Symbol	Condition	Min.	Typ.	Max.	Unit
Starting voltage	Vst	RL=30kΩ			0.9	V
Holding voltage	Vhold	Iout=1mA			0.7	V
Current consumption	Iss	Iout=100μA, Vin=1.5V		8.0	16.0	μA
Output voltage	Vout	Iout=1mA, Vin=1.5V	3.21	3.30	3.39	V
Output current of LX pin	Ilx	Vout=3.2V, Vlx=0.4V	80			mA
Leakage current of LX pin	Ilxl	Vout=3.5V, Vlx=3.5V			1.0	μA
Oscillating frequency	Fosc	Vout=3.2V	80	100	120	kHz
Duty ratio	Duty	Vout=3.2V, Switch"ON"	65	75	85	%

ELM93xxxB CMOS High efficiency PFM step-up DC/DC converter

<http://www.elm-tech.com>

■Marking

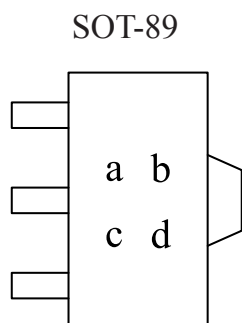

a : the integer digit of the output voltage

Mark	Vout
1	1.*V
2	2.*V
3	3.*V

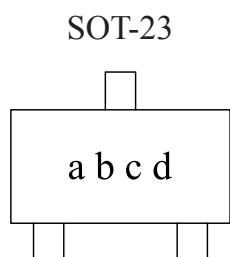

b : the decimal digit of the output voltage

Mark	Vout
0	*.0V
1	*.1V
2	*.2V
3	*.3V
4	*.4V
5	*.5V
6	*.6V
7	*.7V
8	*.8V
9	*.9V

c, d : Assembly lot No. ——— 50 to 99

■External parts

To design DC/DC converters using ELM93 series, coil, diode, and capacitor are necessary.
(Refer to the standard circuit configuration.)

1) Coil

When choosing choke coil, please select that whose core is not magnetically saturated, DC resistance is low, and which has sufficient margin for rated current.

For ELM93 series, ELM recommends following coil.

- CM-5/CM-5N (Sumida Electric Co., Ltd.)

2) Diode

When choosing diode, please select that whose forward voltage is small, switching speed is high and which has sufficient margin for rated current.

For ELM93 series, ELM recommends schottoky diodes.

ELM93xxxB CMOS High efficiency PFM step-up DC/DC converter

<http://www.elm-tech.com>

3) Capacitor

When choosing capacitor, please select that which is generally used for smoothing power supply circuit, with comparatively large capacity and whose rated voltage is at least three times larger than rated output voltage of used ELM93 series.

For ELM93 series, ELM recommends Aluminum electrolytic or Tantalum capacitor.

Under different conditions, such as different input voltage, load current, etc. larger output voltage ripple may happen and thus result in intermittent switching. To solve this, using capacitors with larger capacity can prevent output voltage ripple from becoming larger.

Inserting resistor, as shown in the following circuit, may also be effective.

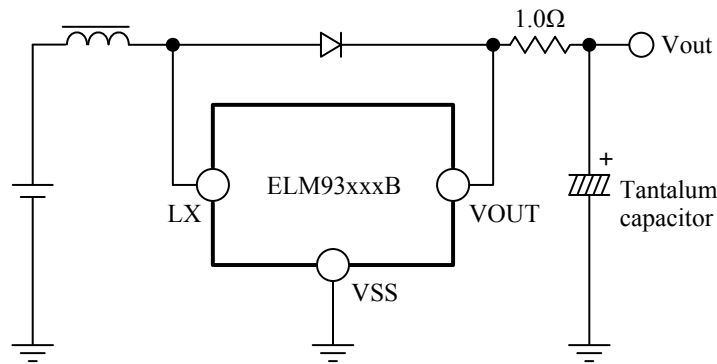

■ Design of DC/DC converter

In the DC/DC converter which consists of ELM93 series and above-mentioned external parts, the output is acquired as follows:

1) Output current of DC/DC converter

The current from the output terminal (VOUT) of the circuit is:

$$I_{out} = K \frac{9V_{in}^2}{32 \cdot L \cdot F_{osc} \cdot (V_{out} - V_{in})} \quad * \text{Duty}=75\%$$

K: the efficiency of whole circuit ($\approx 75\%$ to $\approx 85\%$)

2) Remedies for noise

This DC/DC converter may cause electromagnetic noise due to switching of coil under large current. Solution is necessary especially when the IC is used in wireless devices.

To reduce noise, this IC is designed in consideration of the coil switching characteristics. The following methods are also effective to reduce noise.

- Use shield-type, or magnetic shield coil.
- Locate coil and diode to the LX terminal of IC as close as possible.
- Select ground wire as thick and short as possible.
- Connect ground wire of circuit to one point.

ELM93xxxB CMOS High efficiency PFM step-up DC/DC converter

<http://www.elm-tech.com>

■ Typical characteristics

- $V_{out}=2.7V(ELM9327xB)$ ($T_{op}=25^{\circ}C$, $L=330\mu H$, $D=MA721$, $C_{in}=C_{out}=22\mu F$)

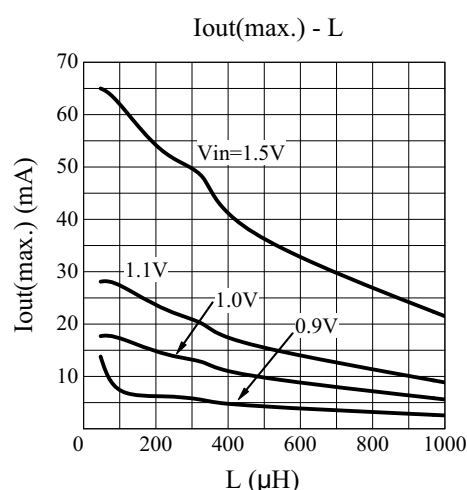
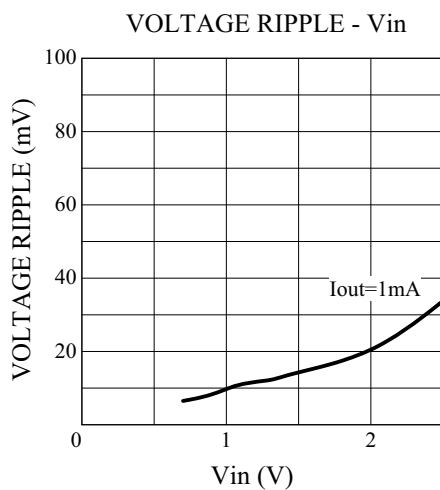
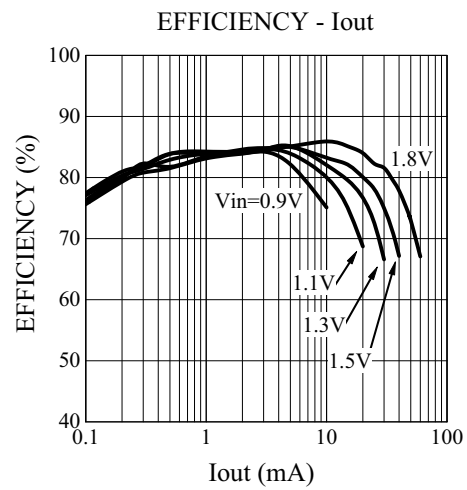
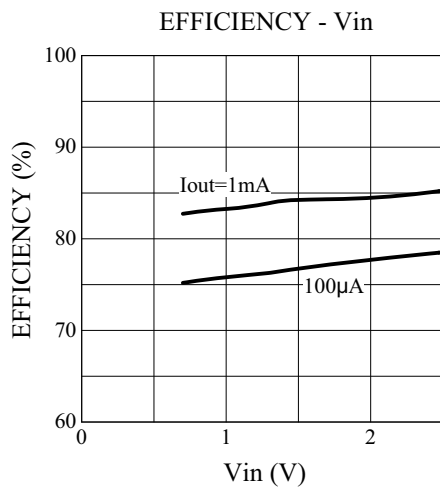
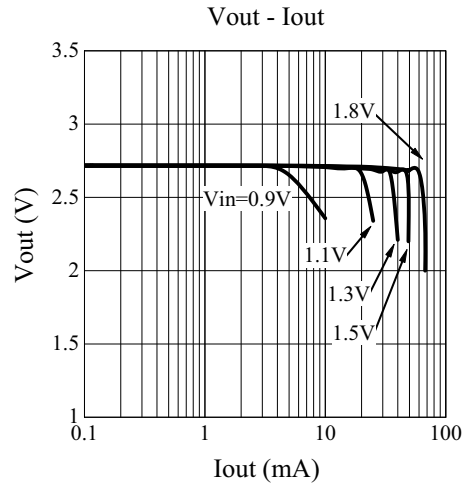
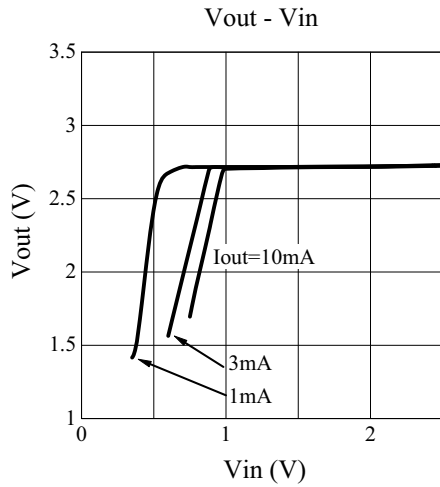

ELM93xxxB CMOS High efficiency PFM step-up DC/DC converter

<http://www.elm-tech.com>

- $V_{out}=3.0V$ (ELM9330xB) ($T_{op}=25^{\circ}C$, $L=330\mu H$, $D=MA721$, $C_{in}=C_{out}=22\mu F$)

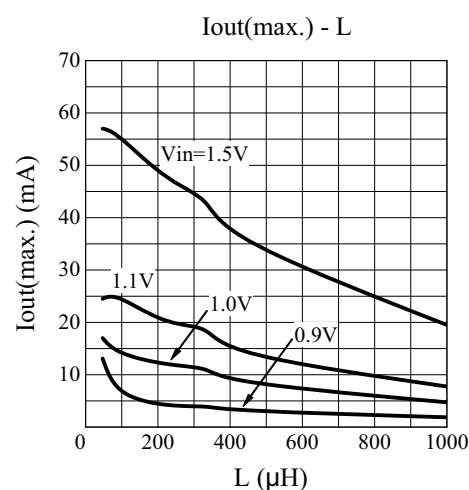
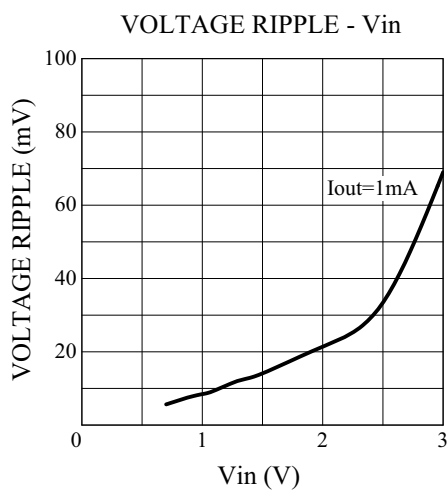
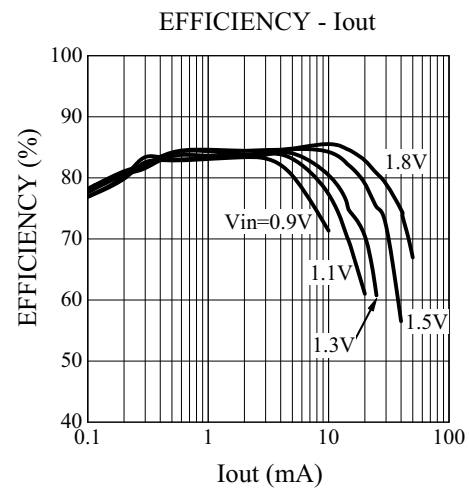
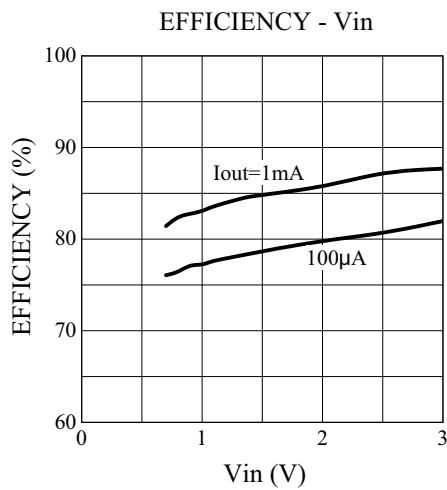
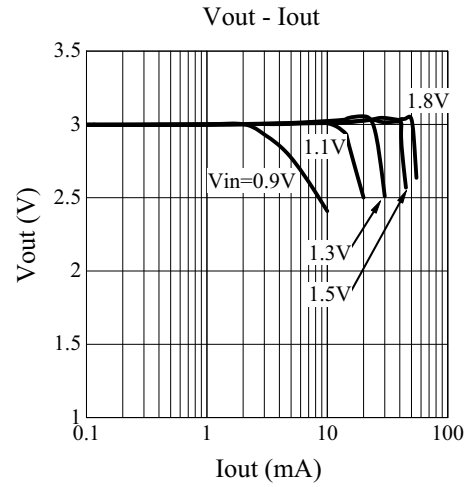
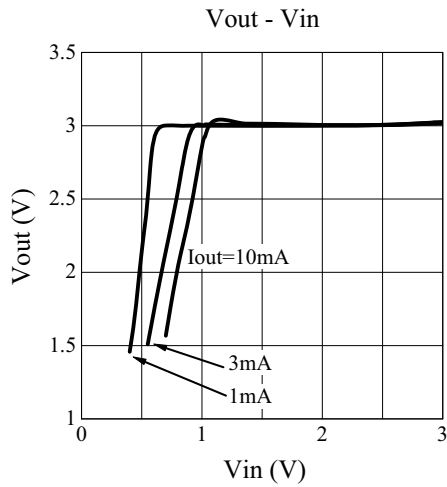

ELM93xxxB CMOS High efficiency PFM step-up DC/DC converter

<http://www.elm-tech.com>

- $V_{out}=3.3V$ (ELM9333xB) ($T_{op}=25^{\circ}C$, $L=330\mu H$, $D=MA721$, $C_{in}=C_{out}=22\mu F$)

