



# ELOTECH

## R 1100 The Temperature Controller

Heat-only Controller  
Heating-off-Cooling Controller



DIN-Format: 96 x 96 mm  
Installation depth: 67 mm

## Description and Operating Manual

ELOTECH Industrieelektronik GmbH  
Verbindungsstrasse 27  
D – 40723 HILDEN  
FON +49 2103 / 255 97 0  
www.elotech.de

FAX +49 2103 / 255 97 29  
Email: info@elotech.de

# I. Contents

I.	Contents.....	2
II.	Type Code .....	2
III.	Connection Diagram .....	3
IV.	Installation Instructions .....	4
V.	Display and Keyboard .....	5
VI.	Operating Levels.....	6
VII.	Configuration Level .....	7
VIII.	Parameter Level .....	10
IX.	OPERATING LEVEL .....	13
X.	Technical Data .....	14
XI.	Error displays .....	15

**Please read this operating manual before starting up carefully.  
Observe the installation and connecting instructions.**

**Before operation, the unit must be configured for its intended purpose under an expert guidance.**  
(e.g. controller type, sensor type and range, alarm adjustment etc.)

**See:** „Configuration Level“ and „Parameter Level“

**Attention:** The „heating“- or „cooling“-outputs can be active while programming or configuring the controller.  
This can cause a damage either to the plant itself or its contents.

## Disclaimer of liability

We have checked the contents of the document for conformity with the hardware and software described. Nevertheless, we are unable to preclude the possibility of deviations so that we are unable to assume warranty for full compliance. The information given in the publication is, however, reviewed regularly. Necessary amendments are incorporated in the following editions.

We would be pleased to receive any improvement proposals which you may have.

**The information contained herein is subject to change without notice.**

## II. Type Code

R 1100 - x - 00 - z

		<b>z: 1</b> Power supply: 230 V AC
		<b>z: 2</b> Power supply: 115V AC
		<b>z: 3</b> Power supply: 24V AC
		<b>z: 5</b> Power supply: 24V DC (+/-25%)
<b>x: 10</b>	Control output OUT1:	Relay, control output „heating“ or „cooling“
	Output OUT2:	Relay, control output „cooling“ or „alarm 2“ output
	Output OUT3:	Relay, „alarm 3“ output
<b>x: 20</b>	Control output OUT1:	Bist. Voltage, control output „heating“ or „cooling“
	Output OUT2:	Relay, control output „cooling“ or „alarm 2“ output
	Output OUT3:	Relay, „alarm 3“ output

### III. Connection Diagram

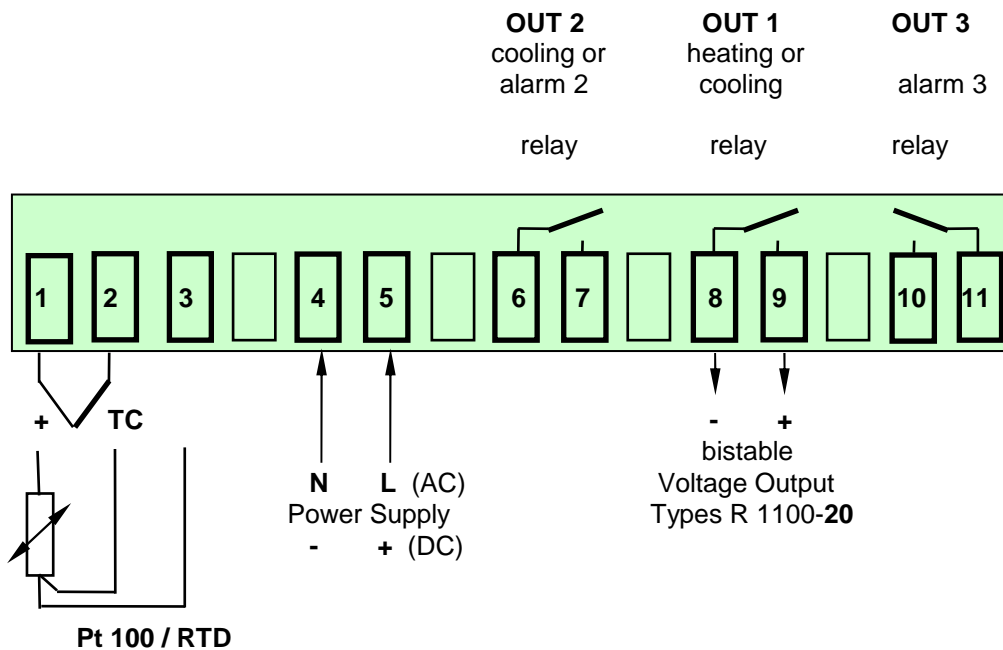

It is not permitted to connect the grounds of the sensor- and bistable voltage outputs with each other.

**Control output OUT 1:**

2-point-controller: "Heating" e.g. „Cooling“  
 3-point-controller (heating-off-cooling): „Heating“

**Control- or alarm output OUT 2:**

2-point-controller: "Alarm 2"  
 3-point-controller: „Cooling“

**Alarm Output OUT 3:**

„Alarm 3“

## IV. Installation Instructions

Make certain that the devices described here are used only for the intended purpose. They are intended for installation in control panels. The controller must be installed so that it is protected against impermissible humidity and severe contamination.

In addition, make sure that the permitted ambient temperature is not exceeded.

**The electrical connections must be made according to the relevant locally applicable regulations.**

If using a thermocouple sensor, the compensation cables must be laid directly to the controller terminals.

Transducers must be connected only in compliance with the programmed range.

Transducer cables and signal lines (e.g. logic or linear voltage outputs) must be laid physically separated from control lines and mains voltage supply cables (power cables) and must be shielded.

Spatial separation between controller and inductive loads is recommended.

Interference from contactor coils must be suppressed by connecting adapted RC-combinations parallel to the coils. Control circuits (e.g. for contactors) should not be connected to the mains power supply terminals of the controller.

### **IMPORTANT:**

Before operation, the unit must be configured for its intended purpose (e.g. controller type, sensor type and range, alarm adjustment etc.).

Please see „Configuration Level“.

## V. Display and Keyboard



Display PROCESS : Process Value  
Display SET : Setpoint Value

LED OUT 1: Output OUT1 active: Control Output  
LED OUT 2: Output OUT2 active: Control Output or Alarm Output A2  
LED OUT 3: Output OUT3 active: Alarm Output A3

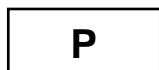

Parameter key



Adjustment of chosen parameter (e.g. setpoint) to higher or lower values.



Short operation: single-step adjustment  
Longer operation: quick-scanning  
When the parameter adjustments have been altered but not with key „E“ entered, the display will flash bright/dark.



Confirmation and storage of the pre-selected values  
The display will shortly be switched dark as a control of this function.



Sets the parameter back to the originally stored value.  
Any alterations made to the parameters, that are not confirmed (E-key) within 30 seconds, will not be accepted and the parameter will return to its originally stored value.

## VI. Operating Levels

The operation of the controller is divided into three levels.

Two seconds after switching on the unit, the controller will automatically be in the operating level.

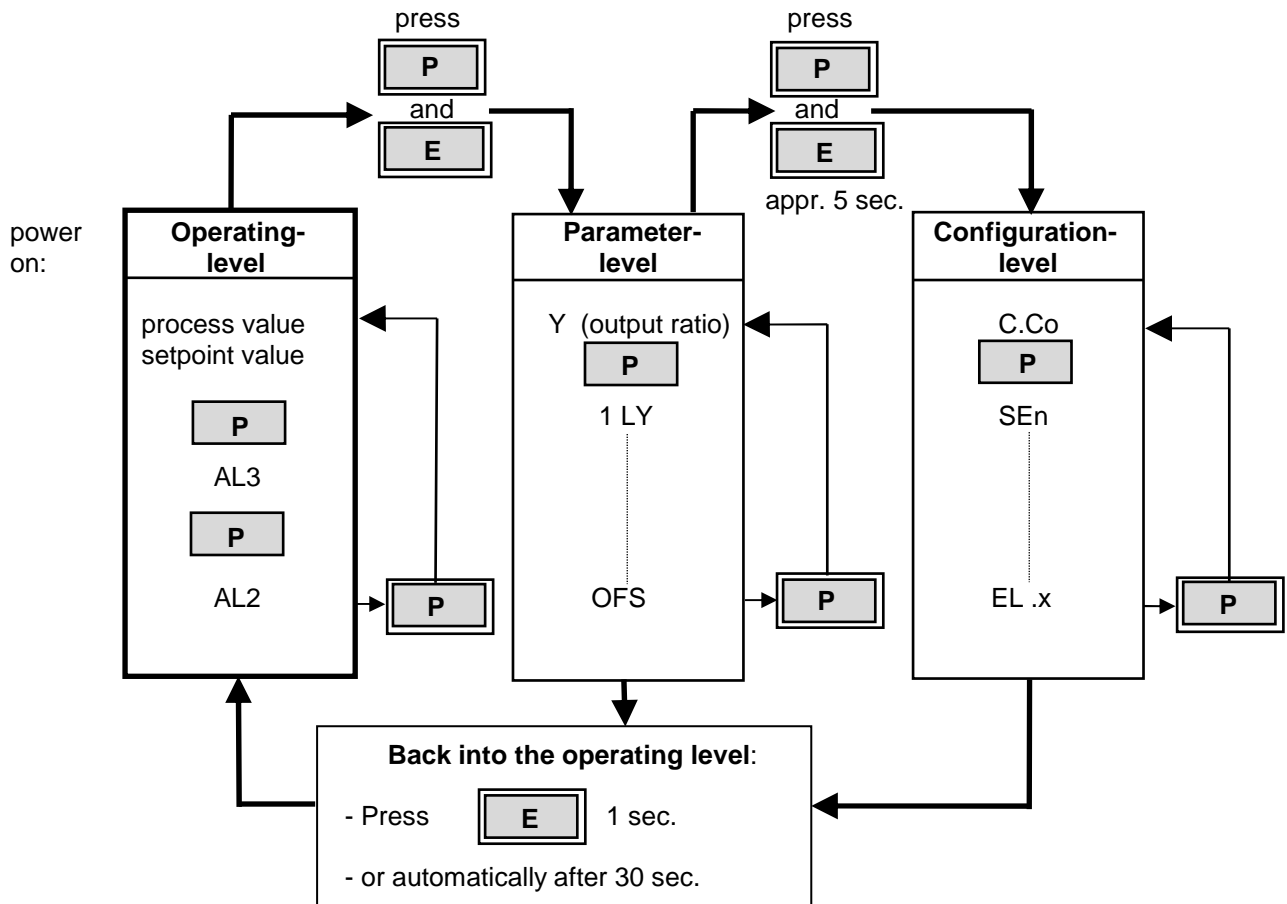

### Operating level

Process- and Setpoint value will be displayed simultaneously.

Within the operating level the setpoint and the alarm value can be adjusted by pressing the "▲"/"▼" - keys.

Every adjustment has to be quit by pressing the „E“ - key.

All parameters within the operating level can, in succession, be displayed by pressing the „P“ - key and adjusted by pressing the "▲"/"▼" - keys.

### Parameter level

Within the parameter level the values are adjusted to suit each individual process.

This level is reached by simultaneously pressing the "P" - and "E" -keys.

### Configuration level

In the configuration level the controller type, input type, sensor range and the alarm behaviour can be pre-selected.

**This primary information has to be entered before taking the controller into operation.**

The configuration level is reached by simultaneously pressing the "P" - and "E" - keys for a period of approx. 5 seconds.

The display of each single parameter within the parameter and configuration levels, and their adjustment, are made in the same fashion as within the operating level.

After either pressing the „E“ - key for approx. 1 second, or waiting for a period of approx. 30 seconds, the unit will automatically return to the operating level (display of process value and setpoint).

## VII. Configuration Level

Display "Process"	Parameter	Display „Set“			
<b>C.Co</b>	<b>Controller configuration</b>	2 h	2-point-controller	„heating“	(ex works)
		2 c	2point-controller	„cooling“	
		2nc	2point-controller	„cooling“ with non-linear cooling	
		3	3-point controller	"heating - off - cooling"	
		3nc	3-point controller	"heating - off - cooling" cooling mode with non-linear cooling*)	

\*) non-linear cooling:  
Cooling action can be pre-selected with either linear or non-linear cooling response curve ( e.g. for vapour cooling).

<b>SEn</b>	<b>Sensor selection</b>	P1C	Pt 100,	0,0...99,9	°C
		P1F	Pt 100,	32...212	°F
		P2C	Pt 100,	-100...+200	°C
		P2F	Pt 100,	-148...+392	°F
		P4C	Pt 100,	0...400	°C (ex works)
		P4F	Pt 100,	32...752	°F
		P8C	Pt 100,	0...800	°C
		L4C	T/C Fe-CuNi (L),	0...400	°C
		L4F	T/C Fe-CuNi (L),	32...752	°F
		L8C	T/C Fe-CuNi (L),	0...800	°C
		J8C	T/C Fe-CuNi (J),	0...800	°C
		n1C	T/C NiCr-Ni (K),	0...999	°C

If the Sensor selection is changed, the following parameters will be reset (setting in brackets) and need to be re-adjusted:

The setpoint (OFF); the alarm value(s) (OFF); the process value offset (OFF);  
the lower setpoint limitation (SP.L); the higher setpoint limitation (SP.H).

### SP.H higher setpoint limitation

programming range: SP.L ... top range (ex works: 400)

### SP.L lower setpoint limitation

programming range: bottom range ... SP.H (ex works: 0)

Display  
"Process"

Parameter

Display  
„Set“

**C.A3 Alarm 3-Configuration**  
(OUT 3)

OFF  
1  
2  
3  
4  
5  
6  
7

alarm OFF, no alarm signalisation (ex works)  
signal contact: off-on  
limit contact: off-on  
limit comparator: off-on-off  
signal contact: on-off  
limit contact: on-off  
limit comparator: on-off-on  
limit comp. with start-up suppression: off-on-off

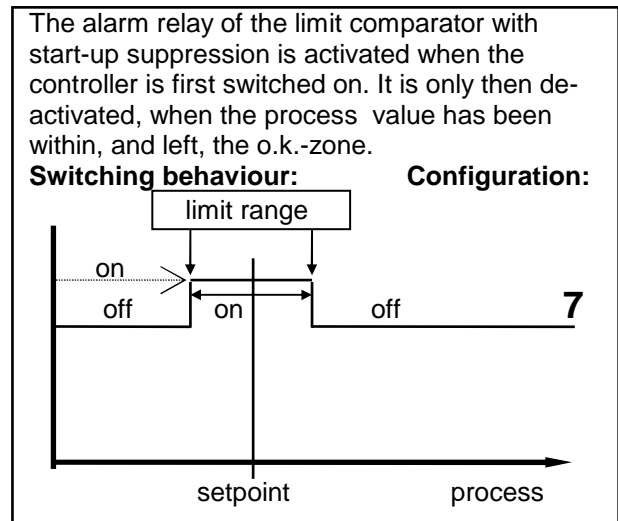
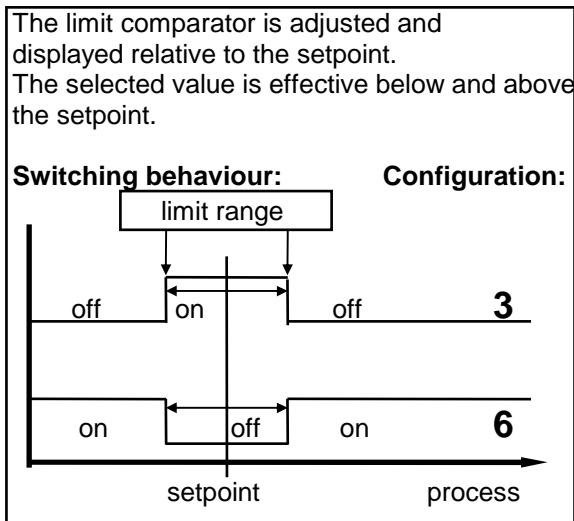
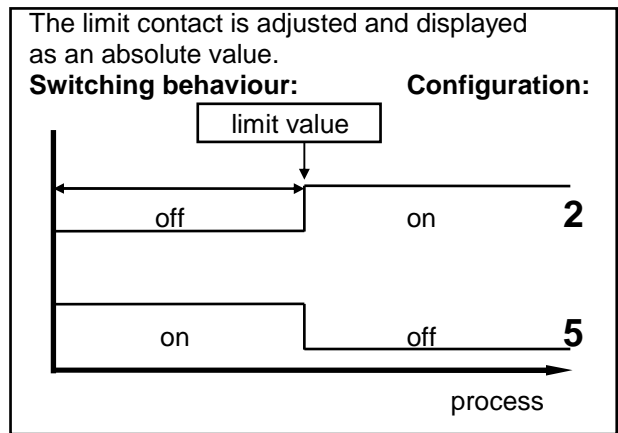
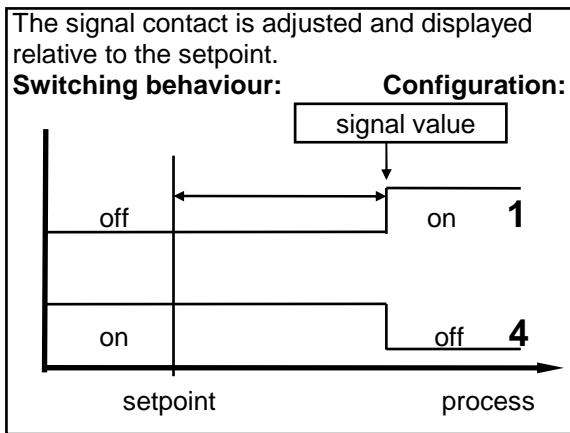

on: Relay "activated"  
off: Relay "not active"

**Please note:**

In case of sensor error the alarms will react in the same way as range override. The alarm contacts therefore do not offer protection against all types of plant breakdown. With this in mind, we recommend the use of a second, independent monitor unit.



Display "Process"	Parameter	Display „Set“	
<b>C.A2</b>	<b>Alarm 2-Configuration</b> (OUT 2)	OFF 1 2 3 4 5 6 7	alarm OFF, no alarm signalisation (ex works) signal contact: off-on limit contact: off-on limit comparator: off-on-off signal contact: on-off limit contact: on-off limit comparator: on-off-on limit comp. with start-up suppression: off-on-off
<b>LOC</b>	<b>Adjustment lock</b>	OFF P C n.SP ALL	no adjustment lock (ex works) parameter and configuration levels locked all parameters apart from SP locked (not SP) all parameters locked
All parameters that have been locked with „LOC“ can be selected and read, but not altered.			
<b>r 1 1</b>	<b>EL.x Control number</b>		end of configuration level

## VIII. Parameter Level

Display "Process"	Parameter	Display „Set“
Y	valid output ratio	-99...100 % The output ratio shows the momentary calculated ratio. It cannot be altered. The display is in percent of the installed performance capability for heating or cooling. Output ratio for cooling is shown as a negative value.
1LY	OUT 1- output ratio limit	0...100 % (ex works: 100)
2LY	OUT 2- output ratio limit	0...100 % (ex works: 100) Only adjustable, if a heating-off-cooling mode is programmed.  A limitation of the output ratio is only necessary when: - the heating or cooling energy supply is grossly overdimensioned compared to the power required, or - to turn off a control output (setting = 0%). Under normal circumstances no limitation is needed (setting = 0%). The limitation becomes effective, when the controllers' calculated output ratio is greater than the maximum permissible (limited) ratio. <b>Warning!</b> The output ratio limitation does not work during autotune.
1 P	OUT 1- Xp prop. band (P)	OFF; 0,1...99,9 % (ex works: 3,0) if Xp = OFF, the next parameter to follow is „1Sd“ = control sensitivity OUT 1
1 d	OUT 1- Tv rate (D)	OFF; 1...200 secs (ex works: 30)
1 J	OUT 1- Tn reset (I)	OFF; 1...999 secs (ex works: 150)  Normally the controller works using PD/I control action. This means, controlling without deviation and with practically no overshoot during start-up. The control action can be altered in its structure by making the following adjustments to the parameters: a. no control action, on-off (setting P = OFF) b. P-action (setting D and I = 0) c. PD-action (setting I = 0) d. PI-action (setting D = 0) e. PD/I modified PID-action
1CY	OUT 1- cycle time	0,5...99,9 secs (ex works: 15,0) The switching frequency of the actuator can be determined by adjusting the cycle time. This is the total time needed for the controller to switch on and off once. a) Relay outputs: cycle time > 10 secs b) Bistable voltage outputs: cycle time 0,5...10 secs

Display  
"Process"

Parameter

Display  
„Set“

Only if 1 P = OUT1 - Xp = OFF :

**1Sd control sensivity OUT1:** OFF; 0,1...80,0 °C/F (ex works: 0,1)

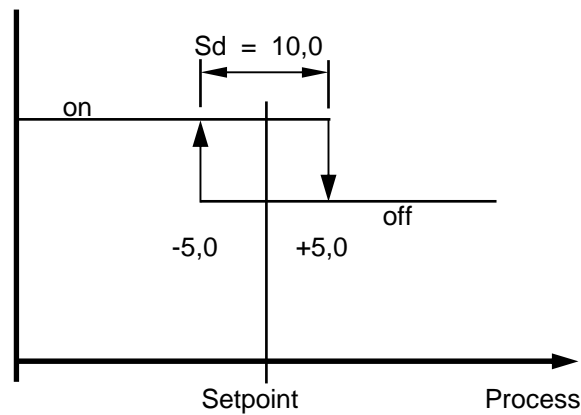

The following parameters apply only to the configuration of a heating-off-cooling controller:

Parameter	Description	Range	Example
<b>Sh</b>	<b>switch-point difference</b>	OFF; 0,1...80,0 °C/F	(ex works: OFF)
	This parameter raises the setpoint (switch-point) for cooling output by the displayed value. It can be help to reduce the switching frequency between the heating and cooling outputs, if this is to high. Simultaneously activation of heat and cool outputs is not possible.		
<b>2 P</b>	<b>OUT 2- Xp cooling prop.-band (P)</b>	OFF; 0,1...99,9 % if Xp = OFF, the next parameter to follow is „2Sd“ = control sensivity OUT 2	(ex works: 6,0)
<b>2 d</b>	<b>OUT 2- Tv cooling rate (D)</b>	OFF; 1...200 secs	(ex works: 150)
<b>2 J</b>	<b>OUT 2- Tn cooling reset (I)</b>	OFF; 1...999 secs	(ex works: 15,0)
<b>2CY</b>	<b>OUT 2- cycle time cooling</b>	0,5...99,9 secs	(ex works: 15,0)

Only if 2 P = OUT2 (cooling) - XP = OFF :

**2Sd control sensivity OUT2** OFF; 0,1...80,0 °C/F (ex works: 0,1)

Display "Process"	Parameter	Display „Set“
----------------------	-----------	------------------

<b>OPt</b>	<b>self tuning</b> (autotune)	OFF	self tuning out of action
		on	self tuning on request ( one time)
		Auto	self tuning automatically if the controller is switched on and if the difference between process value and setpoint is > 7 % of the range.

The tuning algorithm determines the characteristic values within the controlled process, and calculates the valid feedback parameters ( P,D,I ) and the cycle time (  $C = 0.3 \times D$  ) of a PD/I-controller for a wide section of the range.

The determined parameters for heating are also adopted for cooling.

The self tuning activates during start-up shortly before the setpoint is reached. The setpoint must amount to the least 5% of the total range.

If activated after the setpoint has already been reached, the temperature will first drop by approx. 5% of the total range, in order to detect the exact amplification of the process.

The tuning algorithm can be activated at any time by selecting the OPT=on and pressing the „E“-key. During self tuning „Opt“ is shown in the display, alternating with the setpoint value.

Using the heat-cool controller, the temperature drop will be accelerated by switching on the cooling for a short duration.

After having calculated the correct feedback parameters, the controller will lead the process value to the setpoint.

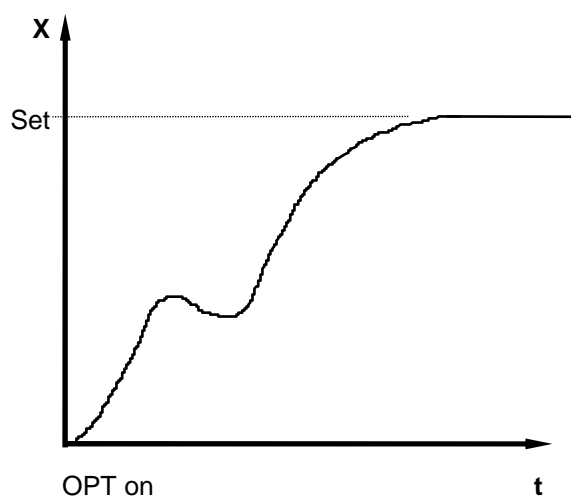

OPT on  
**Self tune during start-up**

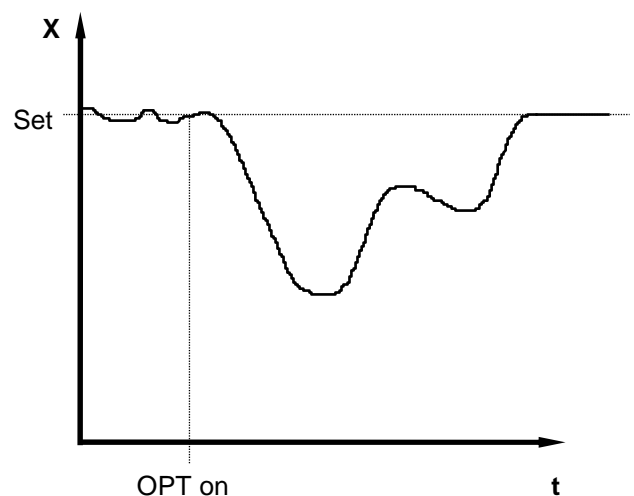

OPT on  
**Self tune, after the setpoint has already been reached**

Self-tuning can be stopped by selecting the option OPT = OFF and pressing the „E“ - key.

<b>OFS</b>	<b>process value offset</b>	-199 ... OFF ...+199	°C/°F	(ex works: OFF)
		-19,9 ... OFF ... +19,9	°C/°F	

This parameter serves to correct the input signal, e.g. for:

- the correction of a gradient between the measuring point and the sensor tip,
- the line resistance balancing of 2-line RTD (Pt100) sensors and
- correction of the control deviation when using P- or PD-action.

If for example the offset value is set to +5°C, then the real temperature measured by the sensor (when process is balanced) is 5°C less than the setpoint and the displayed process value.

## IX. OPERATING LEVEL

Display "Process"	Parameter	Display "Set"
----------------------	-----------	---------------

---

**Process**  
(process)

and

Setpoint (set)	OFF, SP.L...SP.H 4) (ex works: 0)
-------------------	-----------------------------------

**are displayed simultaneously (basic setting).**

If setpoint (SP) is set to "OFF", the controller switches to stand-by.  
The process display then shows "OFF".  
All main outputs are switched off and the alarm is de-activated.  
All parameters can be displayed and altered during stand-by.

**AL3 Alarm 3, Out3**

signal contact, setpoint dependent	(ex works)
OFF; -199...199 °C/F	
OFF; -19,9...+19,9 °C/F	

limit comparator, setpoint dependent  
OFF; 1...199 °C/F      The range of  
adjustment is dependant on the sensor and the alarm configuration.  
Both have to be set in the configuration level.  
(ex works)

OFF; 0,1...19,9 °C/F
----------------------

limit contact, process value dependent
OFF; range bottom ... range top

The range of adjustment is dependant on the sensor and the alarm configuration.  
Both have to be set in the configuration level.

Alarm 2 is only available, if the controller is programmed as a 2-point-controller in the configuration level.

**AL2 Alarm 2, Out2**

signal contact, setpoint dependent	(ex works)
OFF; -199...199 °C/F	
OFF; -19,9...+19,9 °C/F	

limit comparator, setpoint dependent	(ex works)
OFF; 1...199 °C/F	
OFF; 0,1...19,9 °C/F	

limit contact, process value dependent
OFF; range bottom ... range top

The range of adjustment is dependant on the sensor and the alarm configuration.  
Both have to be set in the configuration level.

## X. Technical Data

<b>Input Thermocouple:</b>	Built-in internal compensation point and protection against sensor breakage and incorrect polarity. Re-calibration not required for a line resistance of up to 50 Ohms. Calibration accuracy: $\leq 0,25\%$
<b>Input RTD, Pt 100 (DIN):</b>	2- or 3- wire connection possible. Built-in protection against sensor breakage and short circuit. Max. permissible line resistance by 3-wire connection: 80 Ohms Sensor current: $\leq 0,5 \text{ mA}$ Calibration accuracy: $\leq 0,2 \%$
Linear error:	$\leq 0,2 \%$
Influence of the ambient temperature:	$\leq 0,01 \%$ / K
<b>OUT 1:</b>	Relay, ( n/o contact) max. 250 Vac, max. 3 A (cos-phi = 1) or bist. voltage signal, 0/18 V dc, max. 10 mA, short-circuit proof
<b>OUT 2:</b>	Relay, ( n/o contact) max. 250 Vac, max. 3 A (cos-phi = 1)
<b>OUT 3:</b>	Relay, ( n/o contact) max. 250 Vac, max. 3 A (cos-phi = 1)
<b>7-Segment-Display:</b>	Process: 10 mm red, Set: 10 mm red
<b>Data protection:</b>	EAROM
<b>CE – Mark:</b>	EMC: 2004/108/EC, EN 61326-1 for industrial areas EN 61010-1
<b>Power supply:</b>	Standard: 230 V AC, $\pm 10 \%$ , 48...62 Hz
<b>Connections:</b>	Plug-in screw terminals, Protection mode IP 20 (DIN 40050), Insulation class C
<b>Permissible operating conditions:</b>	Operating temperature: 0...50 °C / 32...122 °F Storage temperature: -30...70 °C / -22...158 °F Climate class: KWF DIN 40040; equivalent to annual average max. 75 % rel. humidity, no condensation
<b>Casing:</b>	Format: 96 x 96 mm (DIN 43700), installation depth 67 mm Panel cutout: 92 +0,5 mm x 92 +0,5 mm Material: Noryl, self-extinguishing, non-drip, UL 94-V1 Protection mode: IP 20 (DIN 40050), IP 50 front side
<b>Weight:</b>	app. 400 g

Subject to technical improvements!

## XI. Error displays

<u>Display</u>	<u>Cause</u>	<u>Possible remedy</u>
<b>SP.L</b> <b>SP.H</b>	Lower setpoint limit has been reached Upper setpoint limit has been reached	Reduce limit, if need be Increase limit, if need be
<b>LOC</b>	Parameter has been locked	Unlock, if need be
<b>Er.H</b>	Top range end has been exceeded, sensor defect	Check sensor and cable
<b>Er.L</b>	Bottom range end has been exceeded, sensor defect	Check sensor and cable
<b>Er.O</b>	Self tuning error	Extinguish error signal by pressing the „E“-key. Check the self tuning conditions and restart.
<b>Er.S</b>	System error	Extinguish error signal by pressing the „E“-key. Check all parameters. If the error signal continues please send the controller back to the factory for examination.
<b>Notes:</b>	SP.L = lower setpoint limitation SP.H = upper setpoint limitation	

