



ELOTECH

S1000

Limit controller



Installation depth: 112mm
Format: 22,5mm x 75mm

Description and operating manual

ELOTECH Industrieelektronik GmbH
Verbindungsstraße 27
D - 40723 HILDEN
FON +49 2103 / 255 97 0 FAX +49 2103 / 255 97 29
www.elotech.de Email: info@elotech.de

1 Contents

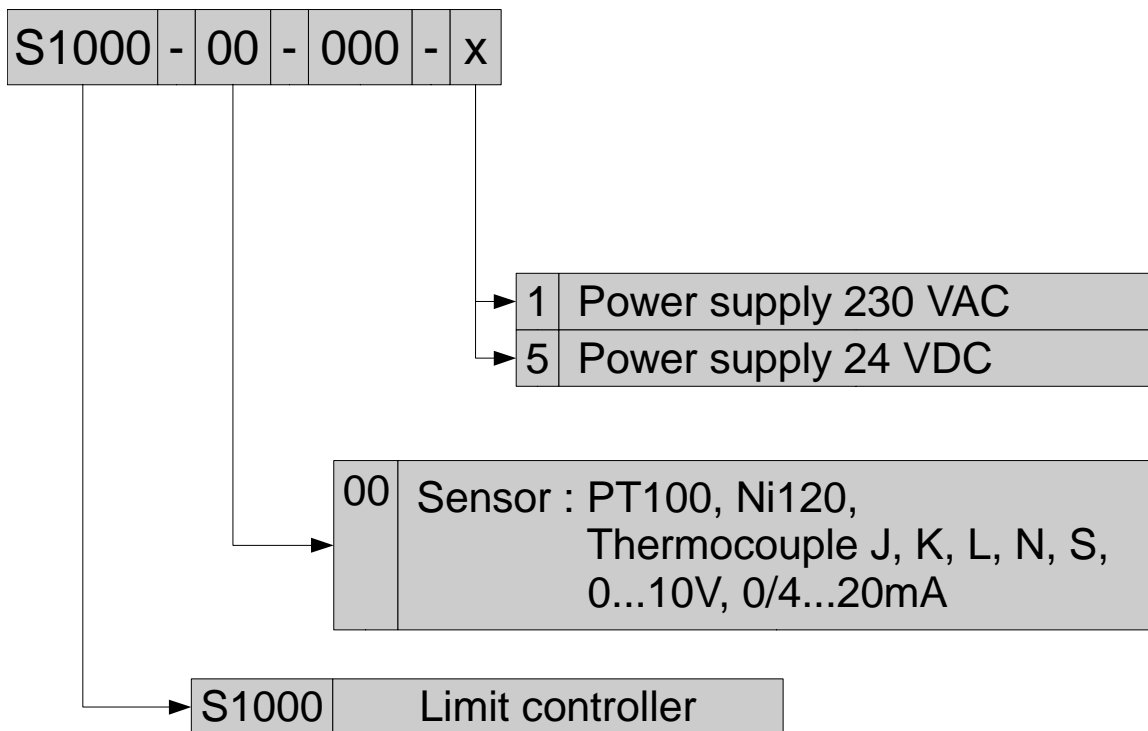

1 Contents.....	2
2 Type Code.....	2
3 General Information.....	3
4 Installation Instructions.....	3
5 Connection Diagram.....	4
6 Display and Keyboard.....	4
7 Operating Levels.....	5
8 Parameter in the Configuration Level.....	6
9 Parameter in the Operating Level.....	7
10 Error Messages.....	7
11 Technical Data.....	8

2 Type Code



3 General Information

Symbols used:

	Messages shown by the controller display
	Symbolizes the value of the factory adjustment of the respective parameter.

4 Installation Instructions

Make sure that the S1000 is used for the intended purpose only.

This device is designed for cap rail mounting.

Protect the device against impermissible humidity and contamination.

Ambient temperature must not exceed 50 °C (122 °F).

Electrical connections must be made according to valid regulations and by properly qualified personnel.

If using thermocouple sensors, compensation lines have to be connected directly to the controller terminals. Sensors may be connected only in compliance with the programmed range.

Separate installation of S1000 and inductive loads is recommended.

Interference from contactor coils must be suppressed by connecting adapted RC-combinations parallel to the coils.

Control circuits (e.g. for contactors) should not be connected to the mains power supply terminals of the S1000

The configuration parameters are generally to be selected first.

Disclaimer of Liability

We have checked the contents of this document for conformity with the hardware and software described. Nevertheless, we are unable to preclude the possibility of deviations so that we are unable to assume warranty for full compliance. However, the information given in the publication is reviewed regularly. Necessary amendments are incorporated in the following editions.

We would be pleased to receive any improvement suggestions which you may have.

The information contained herein is subject to change without notice.

Electronic scrap and components are subject to special treatment and must be disposed of by authorized companies.



5 Connection Diagram

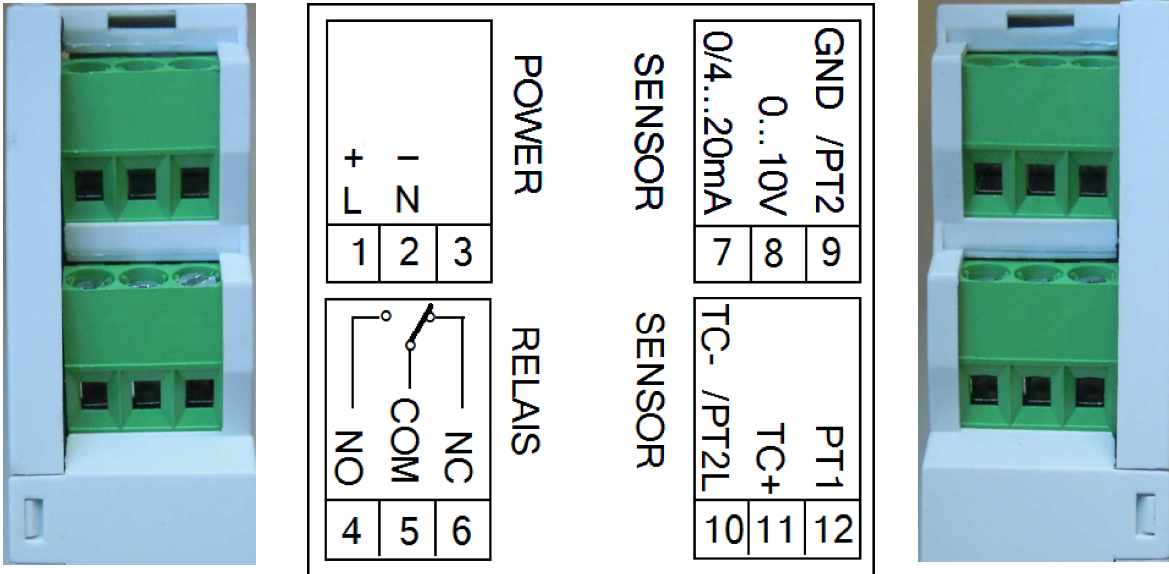

PT100 (RTD) 3-Wire

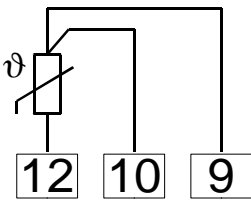

PT100 (RTD) 2-Wire

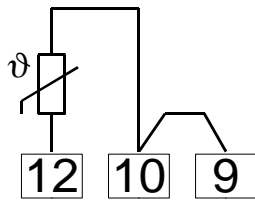

Thermo-couple

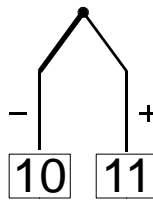

0...10V

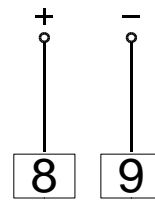

0/4...20mA

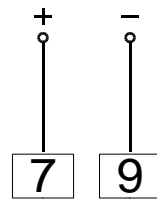

6 Display and Keyboard



Display of actual process value

Display of limit value: flashing dot on top right

Display of alarm relay state:

- Alarm symbol illuminated: relay activated
- Alarm symbol flashing: relay activated and locked (self hold). To be acknowledged by actuation of any key

Keys

7 Operating Levels

After power on the device is in the operating level and displays the actual process value.

▲ E ▼ = Press UP + DOWN at the same time

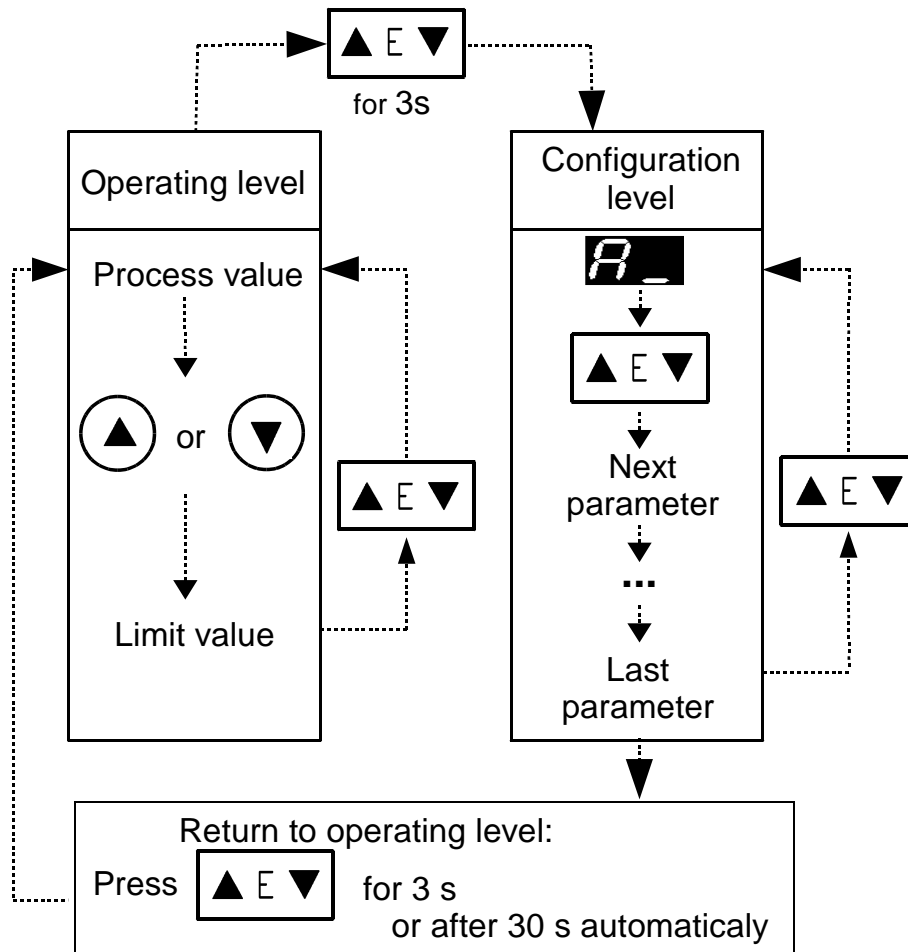

Operating level: Display of actual process value or limit value adjustment

Limit value display and limit value adjustment: press any key.

Limit value is indicated by a flashing dot behind respectively above the value.

Adjustment of limit value by means of keys „▲“ / „▼“.

The value is flashing when being changed.

Press both keys „▲ E ▼“ to save the altered limit value.

Press both keys „▲ E ▼“ again to return to the display of actual process value.

Configuration level: Set up of device

Press both keys „▲ E ▼“ at least 3 s in order to enter the configuration level.

Press both keys „▲ E ▼“ to switch to the next parameter.

Adjust the value by means of the keys „▲“ / „▼“.

The value is flashing when being changed.

Press both keys „▲ E ▼“ to save the altered parameter.

Press both keys „▲ E ▼“ again at least 3 s to get back to the operating level. The device returns automatically to operating mode after 30 s without key actuation.

8 Parameter in the Configuration Level

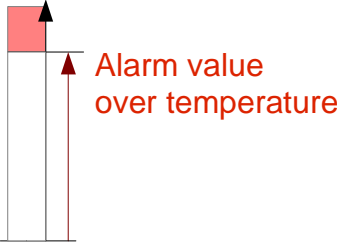
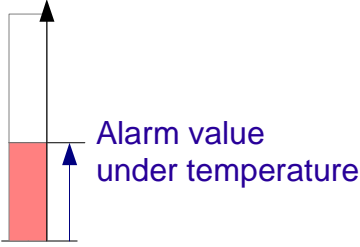
A_ Alarm configuration In the event of a sensor error the alarm relay is generally activated.	A_Hi Over temperature alarm <§> - The temperature has to be higher than the limit value to activate the relais.	
	A_Lo Under temperature alarm The temperature has to be lower than the limit value to activate the relais.	
d_ Alarmdelay	d_ - , d_ 1 ... d_ 9 Delay off <§>, Delay: 1s ... Delay: 9s This delay can prevent false alarms caused by transient variations of the actual process readings and is only effective on activation of the relay.	
H_ Self hold mode	H_of Self hold OFF <§> H_on Self hold active By means of the self hold mode (lock mode) it is possible to memorise transient disturbances. When the relay is being locked the alarm LED is flashing and the relay remains activated. Alarm acknowledge: press any key for release of the relay .	
S_ Sensor selection	S_Pt RTD (Pt100) -100...800°C <§> or -148... 1472°F	
	S_ni Ni120 0...250°C or 32...482°F	
	S_tL Thermocouple Fe-CuNi(L) 0...800°C , 32..1472°F	
	S_tJ Thermocouple Fe-CuNi(J) 0...800°C ; 32..1472°F	
	S_tK Thermocouple NiCr-Ni(K) 0..1200°C ; 32..2192°F	
	S_tS Thermocouple PtRh-Pt(S) 0..1600°C ; 32..2912°F	
	S_tN Thermocouple NiCrSi-NiSi(N) 0..1200°C; 32..2192°F	
	S_0A Linear input 0..20 mA	
	S_4A Linear input 4..20 mA	
S_1v Linear input 0..10 V		

U Display unit	This parameter is only visible a temperature sensor input is selected. U_0C ° Celsius <§> or U_0F ° Fahrenheit.
r_L Linear input range bottom end (range Low)	This parameter is only visible if a linear input is selected. The display switches back and forth between the parameter text and the value to be adjusted. Adjustment range: -1999 ... r_H <§ = 0> The difference between range low and range high must amount to a minimum of 100 units.
r_H Linear input range top end (range High)	This parameter is only visible if a linear input is selected. The display switches back and forth between the parameter text and the value to be adjusted. Adjustment range: r_L ... 2000... <§ = 1000> The difference between range low and range high must amount to a minimum of 100 units.
F Process Filter	F_ - , F_0.1 ... F_99 Filter off <§>, Filter time= 0,1s . Filter time= 9,9s Damping of the actual reading. This is effective on display and on release of alarms as well.

9 Parameter in the Operating Level

Process value	Initial state: display of actual process value. Press any key „▲" or „▼" to display the limit value.
Limit value	For the distinction against the actual process value there is a flashing dot above respectively behind the value. Adjustment range: OFF <§>, lower range value ... upper range value If the limit is set to „OFF" the alarm relay is always deactivated.

10 Error Messages

Message	Cause	Possible remedy
Er.Hi	Top range end has been exceeded, sensor defect	Check sensor and cable
Er.Lo	Bottom range end has been exceeded, sensor defect	Check sensor and cable
Err.0 Er.Sy	System errors	Quit error message by pressing both keys ▲ E ▼ Check all parameters. If the error message continues, please send the device back to the manufacturer.

11 Technical Data

Input: Pt100 (RTD)	2- or 3-wire connection possible Built-in protection against sensor break and short circuit Sensor current: < 0,5 mA Calibration accuracy: ... $\leq 0,2\%$ Linear error: ... $\leq 0,2\%$ Influence of the ambient temperature: ... $\leq 0,01\%$ / K
Input: Thermocouple	Built-in internal compensation point and protection against sensor break and incorrect polarity. Re-calibration not required for a line resistance of up to 50 Ohm. Calibration accuracy: ... $\leq 0,25\%$ Linear error: ... $\leq 0,2\%$ Influence of the ambient temperature: ... $\leq 0,01\%$ / K
Input: Linear	0/4...20mA or 0...10V, The display range is adjustable. Calibration accuracy: < 0,2 % Linear error: < 0,2 % Influence of the ambient temperature: ... $\leq 0,01\%$ / K
Output	Relay, change over contact, max. 250 VAC, max. 3 A (resistive load)
Display:	7-Segment, 4 digits; 7 mm red
Data protection	EAROM
CE-mark	Tested according to 2004/108/EG; EN 61326-1 Electrical safety: EN 61010-1
Power Supply	Depends on the version of the device: - 230 V AC, +/-10 %, 48...62 Hz; approx 1 VA - 24 V DC, +/-25 %, approx 1 W
Connections	Screw terminals, Protection mode IP 20 (DIN 40050), Insulation material: PA Conductor cross section: max 2,5 mm ²
Permissible operating conditions	Operating temperature: 0 ... 50°C / 32 ... 122°F Storage temperature: -30 ... 70°C / -22 ... 158°F Climate class: KWF DIN 40040; equivalent to annual average max. 75 % rel. humidity, no condensation
Casing	Material: PA6.6-FR, UL 94-V1 Protection mode: IP 20 (DIN 40050) Mounting: Cap rail, DIN EN 60715 TH 35 Format: Width: 22,5mm Height: 75mm Depth: 112mm
Weight	Approx 100 g (24V DC); Approx 150g (230V AC)

Subject to technical improvements.