



**ELWOOD HIGH PERFORMANCE MOTORS  
H-SERIES MOTOR DATA**

[http://www.elwood.com/dH\\_Mtr\\_Data.pdf](http://www.elwood.com/dH_Mtr_Data.pdf)

MOTOR MODEL		H-3007	H-3016	H-4030-P	H-4030-M	H-4040	H-4050	H-4075	H-6100	H-6200	H-6300	
<b>MECHANICAL DATA (1)</b>												
Rated Torque, Cont (Stall)	Nm	0.8	2.3	3.4	3.4	5.0	6.8	10.2	11.3	22.6	36.7	
	lb-in	7.0	20.0	30.0	30.0	45.0	60.0	90.3	100	200	325	
Peak Torque (Stall)	Nm	2.5	5.7	9.7	6.8	14.0	22	30.5	25.4	40.7	79.1	
	lb-in	21.9	50.0	85.9	60.0	124.0	195	270	225	360	700	
Rated Current	A <sub>0-PK</sub>	3.5	9.5	8.0	16.0	7.0	16.0	17.0	23.0	45.0	65.0	
Rated Power	kW	0.35	0.75	1.1	1.1	1.3	1.9	2.6	2.5	3.4	6.0	
	hp	0.47	1.0	1.5	1.5	1.8	2.6	3.5	3.4	4.6	8.1	
Rated Voltage (Drive Supply)	V <sub>rms</sub>	230	230	230	230	230	230	230	230	230	230	
Rotor Moment of Inertia	kg-m <sup>2</sup>	0.000030	0.000080	0.000250	0.000250	0.000355	0.000460	0.000680	0.001400	0.002400	0.003400	
	lb-in-s <sup>2</sup>	0.00027	0.00072	0.00220	0.00220	0.00315	0.00410	0.00600	0.01200	0.02100	0.03000	
Rotor Moment of Inertia Brake Motors	kg-m <sup>2</sup>	0.000038	0.000089	0.000330	0.000330	0.000435	0.000540	0.000760	0.001700	0.002700	0.003700	
	lb-in-s <sup>2</sup>	0.00034	0.00079	0.00290	0.00290	0.00385	0.00480	0.00670	0.01500	0.02400	0.03300	
Motor Weight	Net, kg / lb	2.6 / 5.8	3.8 / 8.4	6.2 / 13.7	6.2 / 13.7	7.7 / 16.9	9.1 / 20.1	12.2 / 27	18.3 / 41	27.0 / 60	34.8 / 77	
	Shipping, kg / lb	3.0 / 6.6	4.5 / 9.8	6.9 / 15.2	6.9 / 15.2	8.8 / 19.4	10.7 / 23.6	13.9 / 31	19.2 / 43	28.6 / 63	37.7 / 84	
Motor Weight Brake Motors	Net, kg / lb	3.2 / 7.0	4.6 / 10.2	8.4 / 18.5	8.4 / 18.5	10.3 / 22.7	11.3 / 24.8	14.5 / 32	22.9 / 51	31.6 / 70	39.2 / 87	
	Shipping, kg / lb	3.8 / 8.4	5.3 / 11.6	10.0 / 22.0	10.0 / 22.0	11.4 / 25.1	12.9 / 28.4	16.0 / 36	23.8 / 53	32.9 / 73	42.2 / 93	
Damping	Nm/krpm	0.010	0.014	0.034	0.034	0.040	0.045	0.068	0.100	0.160	0.190	
	lb-in/krpm	0.09	0.12	0.3	0.3	0.3	0.4	0.6	0.9	1.4	1.7	
Friction Torque	Nm	0.014	0.028	0.034	0.034	0.051	0.068	0.140	0.140	0.240	0.360	
	lb-in	0.12	0.25	0.3	0.3	0.5	0.6	1.2	1.2	2.1	3.2	
Max. Operating Speed	rpm	5000	5000	4000	4000	3000	4000	3000	3000	3000	3000	
<b>WINDING DATA (1)</b>												
Poles		6	6	6	6	6	6	6	8	8	8	
K <sub>t</sub> , Sine Wave Torque Constant (2)	Nm/A <sub>0-PK</sub>	0.28	0.28	0.5	0.25	0.81	0.5	0.74	0.68	0.66	0.7	
	lb-in/A <sub>0-PK</sub>	2.5	2.5	4.4	2.2	7.1	4.4	6.6	6.0	5.8	6.2	
K <sub>t</sub> , Square Wave Torque Constant (3)	Nm/A <sub>0-PK</sub>	0.31	0.31	0.54	0.27	0.85	0.54	0.81	0.74	0.72	0.77	
	lb-in/A <sub>0-PK</sub>	2.7	2.7	4.8	2.4	7.5	4.8	7.2	6.6	6.4	6.8	
K <sub>e</sub> , Voltage Constant (4)	V <sub>0-PK</sub> /krpm	38	38	60	30	90	60	90	82	80	85	
Winding Resistance Phase to Phase at 25±5°C	Ω ±15%	6.60	1.30	2.00	0.50	2.50	0.69	0.90	0.49	0.18	0.12	
Winding Inductance Phase to Phase	mH	12.0	3.4	9.0	1.9	11.0	3.3	5.4	4.4	2.2	1.2	
Thermal Constant (R <sub>th</sub> )	°C/W	1.2	0.89	0.79	0.79	0.68	0.57	0.48	0.34	0.31	0.24	
Thermal Constant (C <sub>th</sub> )	W-s/°C	500	1483	3646	3646	4350	5053	4750	8824	11613	22500	
Dielectric Rating		Power Leads (R,S,T) to Ground:1500VAC 50/60 Hz for 1 minute.										
(1) Specifications are at 25°C unless otherwise noted.								(3) Peak value of per phase square wave Amperes				
(2) Peak value of per phase sine wave Amperes								(4) Volts 0-Pk Line-Line / kRPM				

<b>STORAGE AND OPERATING CONDITIONS</b>	
Ambient Temperature	Operating: 0° to 40°C (32° to 104°F) Storage: -30° to 70°C (-25° to 158°F)
Relative Humidity	5% to 95% non-condensing

<b>THERMOSTAT RATINGS</b>	
Rated Voltage	0-250 Volts DC or 50/60 Hz AC*
Rated Current	2.5 Amps @ Power Factor of 1.0 1.6 Amps @ Power Factor of 0.6
Maximum Switching Current	5 Amps
Contact Resistance	<0.10 Ohms maximum
Contacts	Normally closed
Insulation Dielectric	Mylar Nomex capable of withstanding 1500 VAC RMS 50/60 Hz for 1 minute
Opening Temperature (+/- 5°C)	140°C

\*The thermostat is normally used as a switch for a 15VDC logic signal.

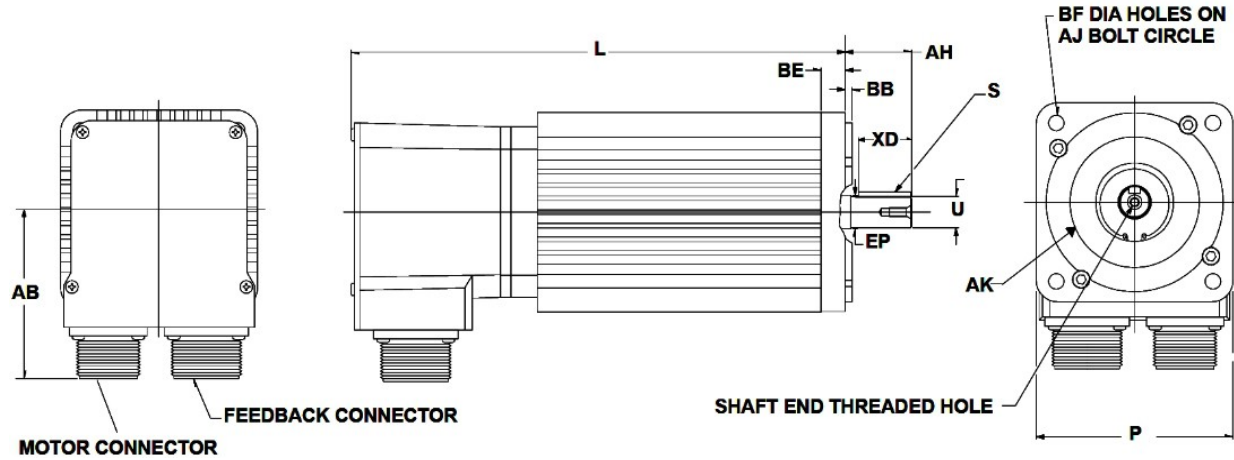

Motor Dimensions														
Motor Model	AB	AH	AJ	AK	BB	BE	BF	EP	L	L Brake	P	S	U	XD
	mm/in	mm/in	mm/in	mm/in	mm/in	mm/in	mm/in	mm/in	mm/in	mm/in	mm/in	mm/in	mm/in	mm/in
H-3007	75/2.95	30/1.18	100/3.94	80/3.15	3/1.2	10.9/4.3	7/2.8	15/5.9	172/6.77	211/8.31	89/3.50	5x5 / 0.20x0.20	14/5.5	20/7.9
H-3016									223/8.77	262/10.31				
H-4030									213/8.39	266/10.45				
H-4040	76/3.00	50/1.97	145/5.71	110/4.33	3/1.2	15.5/6.1	10/3.9	20/7.9	239/9.40	292/11.47	121/4.76	6x6 / 0.24x0.24	19/7.5	40/1.57
H-4050									264/10.39	317/12.48				
H-4075									315/12.40	368/14.49				
H-6100									277/10.91	330/12.99				
H-6200	101/4.00	80/3.15	200/7.87	114.3/4.50	4/1.6	21.3/8.4	13.5/5.3	38/1.50	353/13.90	406/15.98	178/7.01	10x8 / 0.39x0.31	35/1.38	60/2.36
H-6300									429/16.89	482/17.40				

SUPPLEMENTAL MOTOR DIMENSIONS																
Length, from motor faceplate to center of connectors																
CONNECTOR	H-3007	BRAKE	H-3016	BRAKE	H-4030	BRAKE	H-4050	BRAKE	H-4075	BRAKE	H-6100	BRAKE	H-6200	BRAKE	H-6300	BRAKE
Brake (mm/in)	—	107/4.21	—	158/6.22	—	160/6.30	—	211/8.31	—	262/10.31	—	189/7.44	—	265/10.43	—	341/13.42
Encoder & Power (mm/in)	143/5.63	181/7.13	194/7.64	232/9.13	184/7.24	236/9.29	235/9.25	287/11.30	286/11.26	338/13.30	251/9.88	299/11.77	327/12.87	375/14.76	403/15.87	451/17.75

Shaft End Threaded Hole		
Motor Series	Thread	Thread Depth
H-3000	M3 x 0.5MM	10mm / 0.39in
H-4000	M4 x 0.7MM	15mm / 0.59in
H-6000	M6 x 1.0MM	20mm / 0.79in

Note: Motors are manufactured to Millimeter dimensions. Inch dimensions are approximate conversions from millimeters

**ELWOOD HIGH PERFORMANCE MOTORS  
H-SERIES NEMA 56C DIMENSIONAL DATA**

[http://www.elwood.com/dH\\_Mtr\\_Data.pdf](http://www.elwood.com/dH_Mtr_Data.pdf)



Dimensions Motors	Without Brake in/mm	With Brake in/mm
H-4030 NEMA 56C	8.39/213	10.47/266
H-4050 NEMA 56C	10.39/264	12.48/317
H-4075 NEMA 56C	12.40/315	14.49/368

Note: NEMA 56C motors are manufactured to inch dimensions. Millimeter dimensions are approximate conversions from inches.

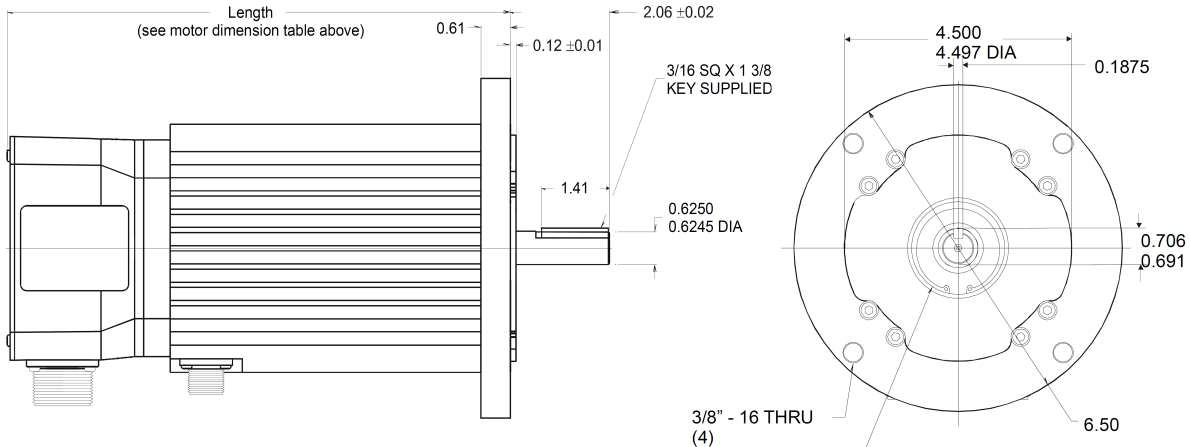

SUPPLEMENTAL MOTOR DIMENSIONS			
Length, from motor faceplate to center of connectors			
Motors	Brake (in/mm)	Power (in/mm)	Encoder (in/mm)
H-4030	---	7.24/184	7.24/184
H-4030 BRAKE	6.30/160	9.29/236	9.29/236
H-4050	---	9.25/235	9.25/235
H-4050 BRAKE	8.31/211	11.30/287	11.30/287
H-4075	---	11.26/286	11.26/286
H-4075 BRAKE	10.31/262	13.30/338	13.30/338

MOTOR WILL ACCEPT 47mm X20mm X 7mm  
SHAFT SEAL (optional, not included)



H-Series Motor Encoder	
Pin	Signal
A	A+
B	A-
C	B+
D	B-
E	I+
F	I-
G	ENCODER CASE
H	ABS
J	+5VDC
K	+5VDC
L	COM
M	COM
N	HALL B
P	HALL C
R	TS+
S	TS-
T	HALL A

MIL-SPEC Part Numbers	
MS3102R20-29P	
Mating Connector: Straight	
MS3106F20-29S	
Mating Connector: Right Angle	
MS3108F20-29S	

H-Series Motor Power	
Pin	Signal
A	R
B	S
C	T
D	MOTOR CASE

MIL-SPEC Part Numbers	
H-3000	MS3102R18-4P
H-4000	MS3102R20-4P
H-6000	MS3102R24-22P
Mating Connector: Straight	
H-3000	MS3106F18-4S
H-4000	MS3106F20-4S
H-6000	MS3106F24-22S
Mating Connector: Right Angle	
H-3000	MS3108F18-4S
H-4000	MS3106F20-29S
H-6000	MS3108F20-29S

H-Series Motor Brake	
Pin	Signal
A	A+
B	A-

MIL-SPEC Part Numbers	
MS-3102R-12S-3P	
Mating Connector: Straight	
MS3106F12S-3S	
Mating Connector: Right Angle	
MS3108F12-3S	

**SHAFT SEALS**

H-Series Motor Shaft Seals		
Motor Series	Part Number	Size (OD x ID x Thickness)
H-3000	0019-1047	35mm x 15mm x 7mm
H-4000	0019-1041	47mm x 20mm 7mm
H-6000	0019-1042	80mm x 38mm x 8mm

**CABLES: CONTINUOUS FLEX RATED\***

\*Elwood's continuous flex rated cables replace both flexing and non-flexing cables for H and F Series motors.

Power Cables	"XXX" indicates length in feet			
	H-2000 & H-3000	H-4000	H-6100 & H-6200	H-6300
Rockwell Model	9101-1381	9101-1382	9101-1383	9101-1399
	2090-UXNPAHF-16S	2090-UXNPAHF-14S	2090-UXNPAHF-10S	2090-UXNPAHF-8S
Elwood Model	2090-XXNPHF-16S	2090-XXNPHF-14S	2090-XXNPHF-10S	2090-XXNPHF-8S
	141-HPXXX-01	141-HPXXX-02	141-HPXXX-03	141-HPXXX-04

Feedback Cables	"XXX" indicates length in feet	
	Ultra 100/200	Ultra 3000 & Kinetix
Rockwell Model	9101-1366	2090-UXNFBHF-S
Elwood Model	141-HFXXX-01	141-HFXXX-02

Brake Cables	"XXX" indicates length in feet	
	For All Drives	
Rockwell Model	n/a	
Elwood Model	141-HBXXX-01	



**H - 4 030 - P - H 00 AA**

