



DSVGA DESIGN REFERENCE BOARD

EMA-200015

For Use with all eMagin DSVGA OLED Microdisplays

USER'S MANUAL

TABLE OF CONTENTS

1. INTRODUCTION	1
2. FEATURES	1
2.1. Software Features	1
3. SYSTEM REQUIREMENTS & SPECIFICATIONS	1
3.1. System Requirements	1
3.2. DSVGA Mini Design Reference Board	2
4. INTERFACE CONNECTIONS & SETUP	3
4.1. Setup Flow Chart	3
4.2. Connect Display to the Design Reference Board	3
4.3. Setup PC for Proper Video Output	4
4.4. Power Up	4
4.5. Power Down	4
4.6. Brightness	5
5. USING THE DSVGA DESIGN REFERENCE BOARD SOFTWARE	6
5.1. DSVGA Design Reference Board Software Utility	6
5.1.1. Hardware Protocol	8
5.3. Downloading New Firmware Versions to the Design Reference Board	9
5.3.1. Using the Firmware Download Utility	9
6. ADVANCED USER INFORMATION	10
6.1. Microcontroller	10
6.2. I ² C bus	10
6.3. Voltages	10
6.4. Bias Control	11
6.5. VCOM Mode	11
6.6. Gamma	11
6.6.1. Gamma Coefficients GC(0-8)	12
6.6.2. Preset Gamma Table descriptions	Error! Bookmark not defined.
6.6.3. Using "Update LUT" Button for Auto-Gamma Correction	12
6.6.4. Loading the LUT from a file	13
6.6.5. The "Read LUT" Button	13
6.6.6. System Gamma	13
7. REVISION HISTORY	15

List of Figures

<i>Figure 3-1 DSVGA Design Reference Board</i>	<i>2</i>
<i>Figure 4-1 DRK Setup Flow Chart</i>	<i>3</i>
<i>Figure 5-1 Firmware download utility</i>	<i>9</i>



1. INTRODUCTION

The DSVGA Design Reference Kit (EMA-200015) provides the user with a compact and portable means of operating and testing an eMagin DSVGA OLED Microdisplay. This product was designed to deliver a complete tool for developers to evaluate and integrate eMagin DSVGA microdisplays into new products. The included software package provides access to the microdisplay's on-board register settings from any Windows-based PC through a USB port and supports all different types of DSVGA OLED Microdisplays:

- DSVGA Monochrome White OLED-XL with glass cover
- DSVGA Color OLED-XL with glass cover
- DSVGA Monochrome Green OLED-XLT with glass cover

2. FEATURES

- HDMI Video Input
- USB interface allows access to microdisplay registers
- Supporting Software (Windows)
- ON/OFF power switch

2.1. Software Features

- Read/write capabilities allow adjustments of microdisplay register settings to fine-tune image characteristics
- Software register control over the microdisplay's brightness
- Download and install new firmware files into your DSVGA Design Reference Board for easy upgrades and expanded functionality
- Save feature stores custom register settings for convenience

3. SYSTEM REQUIREMENTS & SPECIFICATIONS

3.1. System Requirements

- For digital RGB inputs: A PC capable of producing a digital video output compliant with the DVI or HDMI standard.
- Support software requires a Windows PC with a USB port

3.2. DSVGA Design Reference Board

The DSVGA Design Reference Board is shown in figure 3-1 below. The major components are labeled for easier identification. The minimum requirements for displaying video on the DSVGA Design Reference Board are: a USB cable directly connected to PC, a digital video source connected to HDMI connector and a DSVGA OLED connected to the display connector.

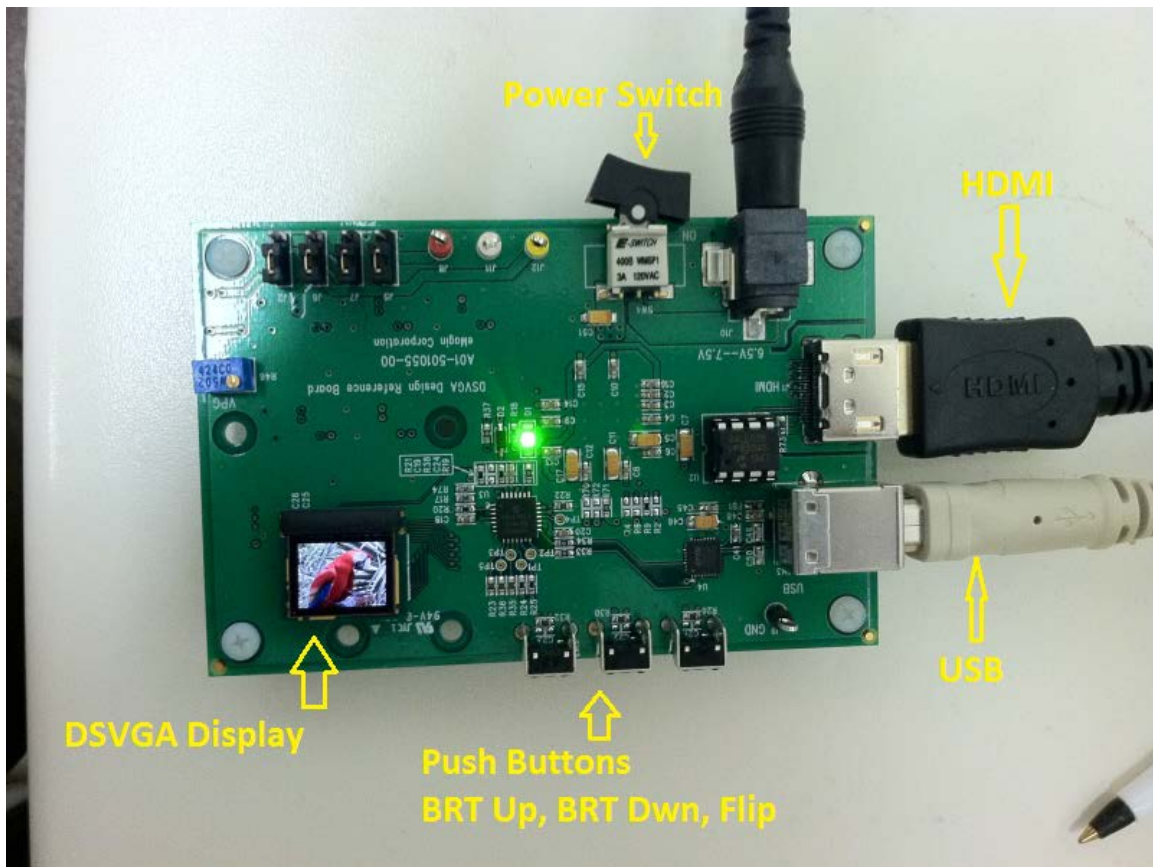

Figure 3-1 DSVGA Design Reference Board

4. INTERFACE CONNECTIONS & SETUP

4.1. Setup Flow Chart

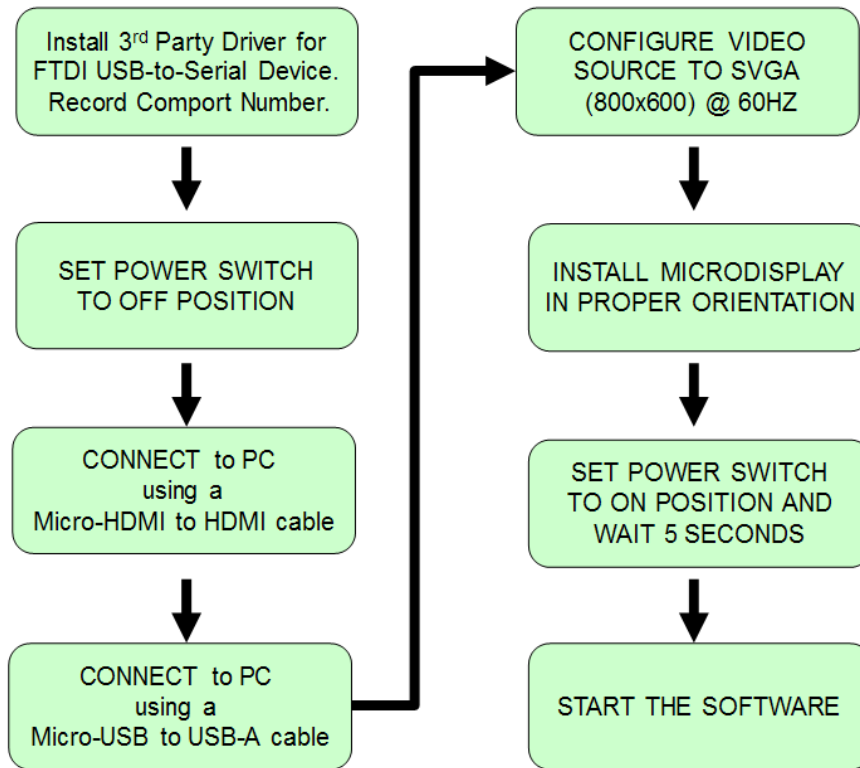

Figure 4-1 DRK Setup Flow Chart

4.2. Connect Display to the Design Reference Board

The microdisplay connects to the Design Reference Board via a 40-pin board-to-board connector. The present version of the connector is **NOT** keyed so it is important to correctly orient the display. Refer to the picture below for the proper orientation. . The Display Carrier board is connected as shown in figure 4-2 below.

Note: The DSVGA OLED can be damaged if it is not connected properly.

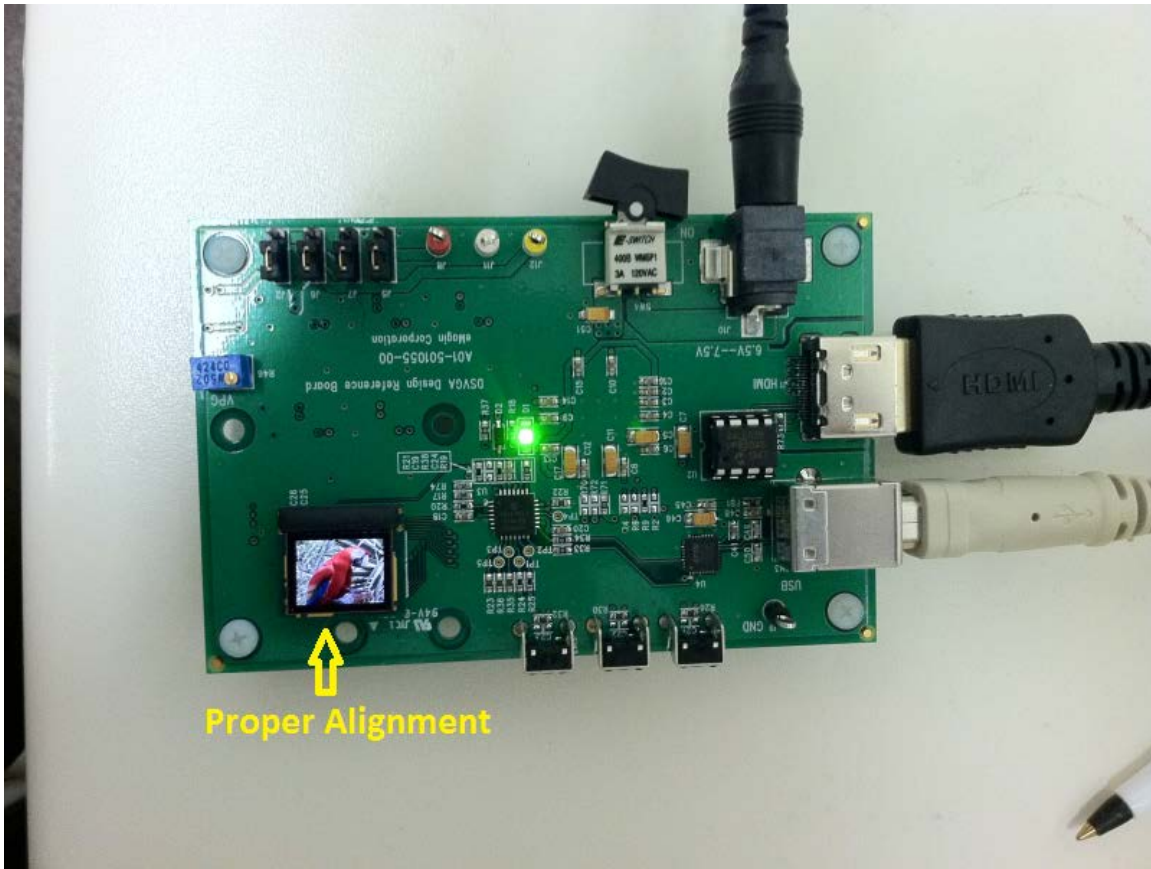

Figure 4-2 Display Carrier Board Connection Orientation

Lift the display by its sides and take care not to press on the glass lid or leave fingerprint marks on it. Insert the display into the Design Reference Board.

4.3. Setup PC for Proper Video Output

- The default compatible resolution is SVGA (800x600) with a refresh rate of 60 Hz. If you are using this input set the video resolution for 800x600 in your PC's display properties.
- Ensure that the refresh rate to set to 60 Hz, or other supported refresh rate per the display specification.
- If you are using a laptop PC, you may need to export the video signal to an external monitor. This is usually accomplished through a key press including the Fn key + a designated function key. See your PC's operation instructions for more information.

4.4. Power Up

- Set the power switch to the ON position.

4.5. Power Down



- Set the power switch to the OFF position.

4.6. **Brightness**

eMagin strongly recommends that you drive the microdisplay at the minimum luminance necessary for your application. This will extend the lifetime of the display to its maximum possible lifetime. As OLED microdisplays are emissive devices, driving the microdisplay at high bias levels will decrease its overall lifetime.

5. USING THE DSVGA DESIGN REFERENCE BOARD SOFTWARE

The DSVGA Design Reference Board includes a support software suite with the following functionality.

- Perform software microdisplay brightness adjustments
- Download and install new versions of the DSVGA Design Reference Board firmware to update or provide new functionality using an USB (RS-232) connection
- Read/write register values to the microdisplay to control various characteristics (see your microdisplay’s User Specification for more information)

5.1. DSVGA Design Reference Board Software Utility

1. Connect the USB cable to the DSVGA Design Reference Board
2. Connect the video source to the DSVGA Design Reference Board
3. Turn on the DSVGA Design Reference Board
4. Check under the PC’s “Device Manager” window to determine serial COM PORT number as shown below:

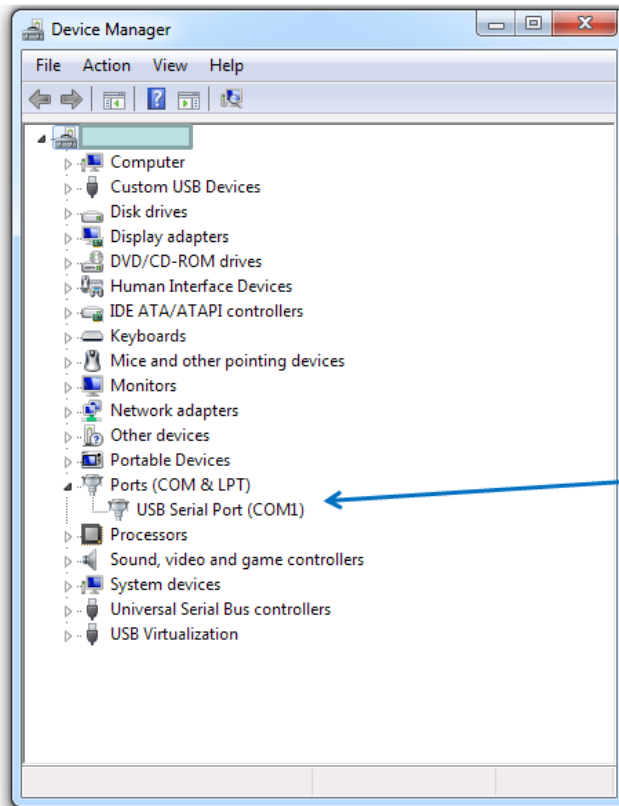

Com port created after installation of the FTDI's USBtoSerial adapter driver. The DRK's USB cable must be connected to the PC.

5. Start the **DSVGA_SW_V1_1.exe** application, enter the correct COM Port number and a screen should appear like that shown below:

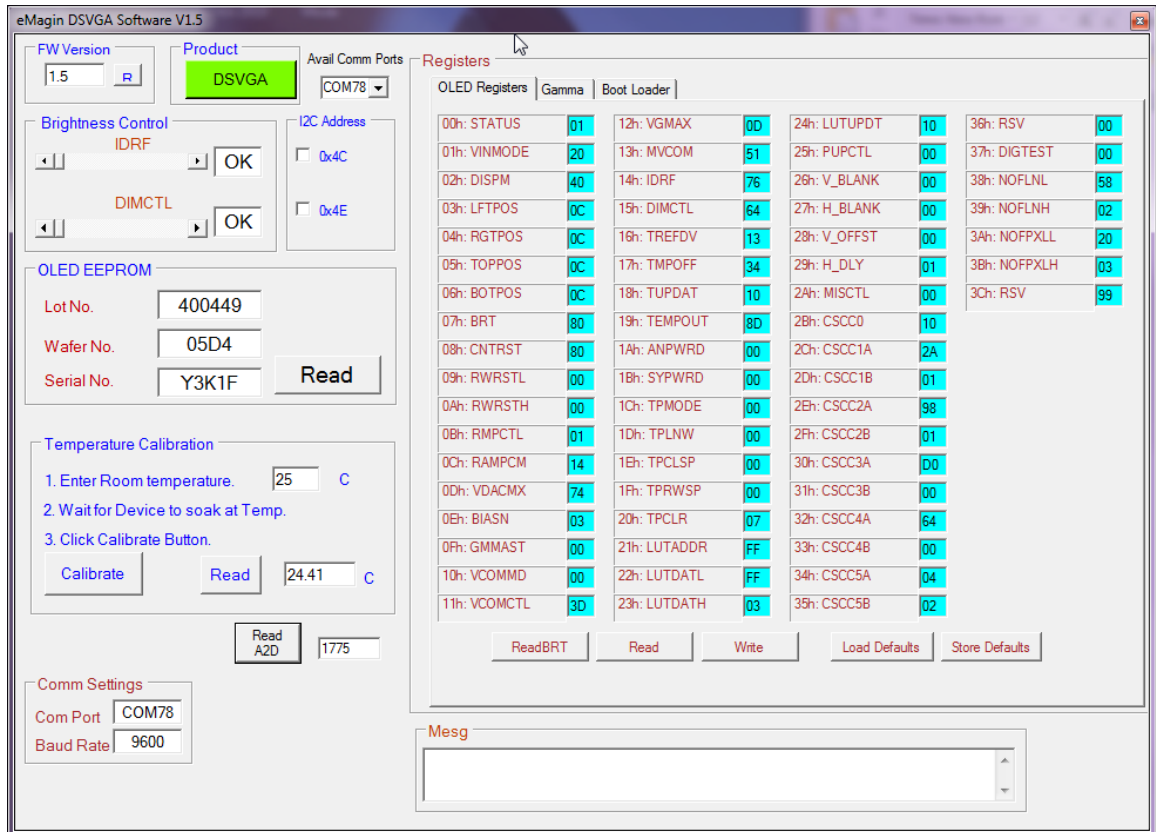

Figure 5-1 DSVGA Design Reference Board Software Utility

6. The application communicates with the PIC on the DSVGA Design Reference Board.
7. The read/write buttons shown in the “OLED Registers” panel will read/write the register settings in their corresponding boxes from/to the OLED microdisplay.
8. The read/write buttons displayed in the “GAMMA GC()” panel will read/write the values used in generating a Gamma table that resides in the display
9. The read/write buttons displayed in the “OLED EEPROM” panel will read/write the values stored in the display’s non-volatile memory.

5.1.1. Hardware Protocol

- 1 stop bit, no parity
- 9600 baud
- No hardware handshake

5.2. Downloading New Firmware Versions to the Design Reference Board

The ability to download new versions of the firmware ensures that you will have the latest functionality without having to send your DSVGA Design Reference Board for reprogramming. A utility that downloads and installs new firmware versions is included in the software package.

5.2.1. Using the Firmware Download Utility

Firmware files can be downloaded as hex files. Before attempting to download and install new firmware versions make sure that you have received a firmware hex file from an eMagin source.

To load your firmware files, follow the following steps:

1. Connect the serial cable to the PC and to the RS232 connector on the DSVGA Design Reference Board
2. Connect the power cable to the DSVGA Design Reference Board.
3. Connect your video source to the DSVGA Design Reference Board.
4. Start the **DSVGA_SW_V1_1.exe** application. Select the “Bootloader” tab at the top of the form. A window should appear like that below:

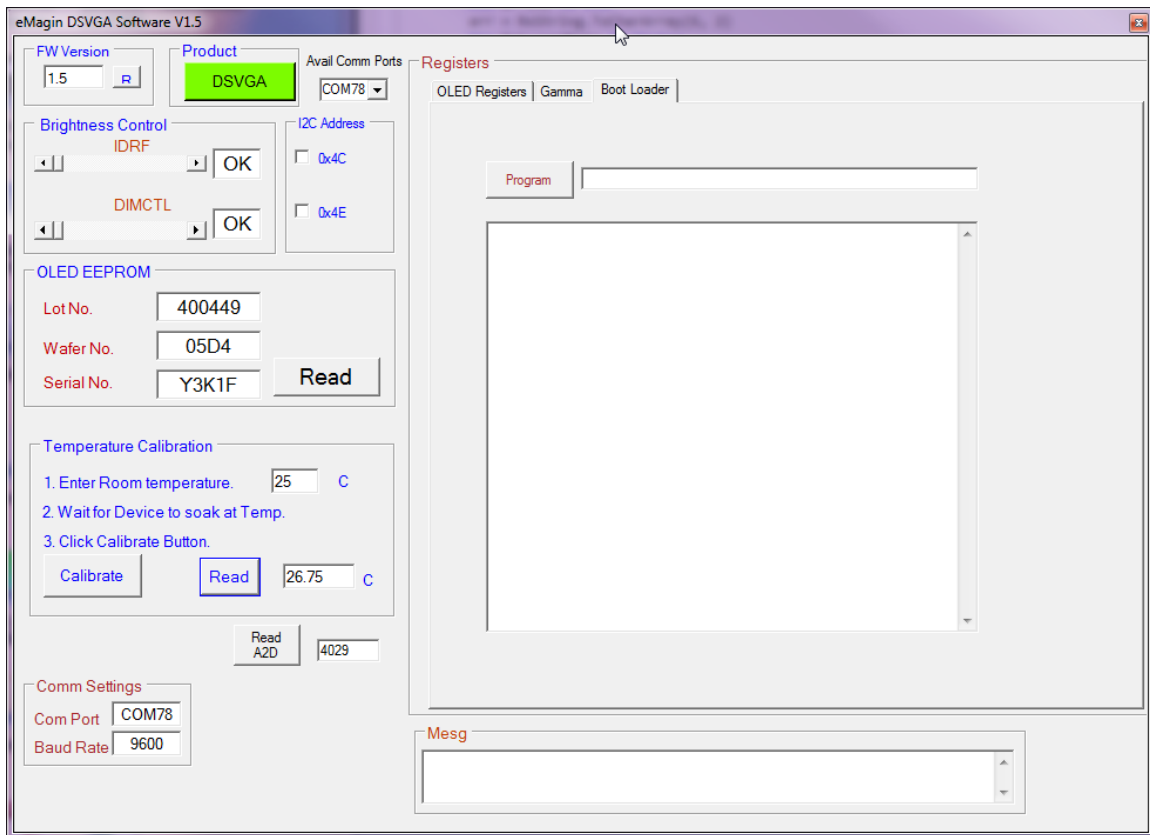

Figure 5-1 Firmware download utility

5. Click the “Program” button to find the hex file you wish to install.
Note: The power on the DSVGA Design Reference Board should be off while setting up your download. Only turn on the power to the DSVGA Design Reference Board when you are ready to write your new firmware to the PIC.
6. When you turn on the DSVGA Design Reference Board the hex file should begin to upload.
7. When the upload is complete, the DSVGA Design Reference Board will run.

6. ADVANCED USER INFORMATION

6.1. Microcontroller

The DSVGA Design Reference Board utilizes a Microchip PIC18F2523 microcontroller. This is a CMOS Flash microcontroller in a 28 pin package. Provisions are on the circuit board for in circuit reprogramming. Please refer to the Microchip PIC18F2523 datasheet available from Microchip Technology Inc. for additional information about the microcontroller and programming.

The main function of the microcontroller is to communicate with the OLED display. All communication is over the internal I²C bus and the microcontroller acts as the bus master. On power up the registers of the OLED is initialized with the default settings programmed into the microcontroller. After initialization the microcontroller scans for user input and monitors the OLED.

6.2. I²C bus

The microcontroller is the bus master and communication occurs at the standard 100 KHz clock rate. The maximum speed allowed for I²C bus communication is 400 KHz. Please refer to the Philips I²C bus specification available on the Philips website for detailed information.

6.3. Voltages

The power supply section of the DSVGA Design Reference Board consists of several voltage regulators, some of which are adjustable with potentiometers. Table 6-1 below describes the voltages and their purpose.

Voltage	Range	Typical	Purpose
Vinput (USB)	+5.0 Volts	+5Volts	Main Supply
V5	5Volts ±10% (fixed)	5 Volts	LEDS, DAC
V3.3	3.3Volts ±10% (fixed)	3.3 Volts	DVI, RS232
V2.5	2.5Volts ±10% (fixed)	2.5 Volts	
VAN	5.0V	5.0 Volts	OLED Anode

VPG	-1.8V	-1.8V	OLED Bias
VDD	1.8V \pm 10% (fixed)	1.8V	OLED

Table 6-1 shows the board's various power supplies and their purposes

6.4. Bias Control

BIASN: Normal board – BIASN=3 gives the best results.

6.5. VCOM Mode

VCOMMODE:

Dimming: use register VCOM to set brightness level in Manual mode.

6.6. Gamma

To compensate for the non-linear dependency of luminance on the voltage of the OLED diode, the R, G and B signals include internal gamma correction to linearize the pixel response as a function of the input video signal. This gamma correction takes place in the PIC microcontroller.

The gamma correction consists of a nine segment piece-wise-linear function whose parameters are set from the pull-down menu or via registers in the “Gamma” panel on the windows software. All three color channels have the same PWL shape.

There are multiple ways to set the Gamma using the windows software. The Gamma section of the software is shown below.

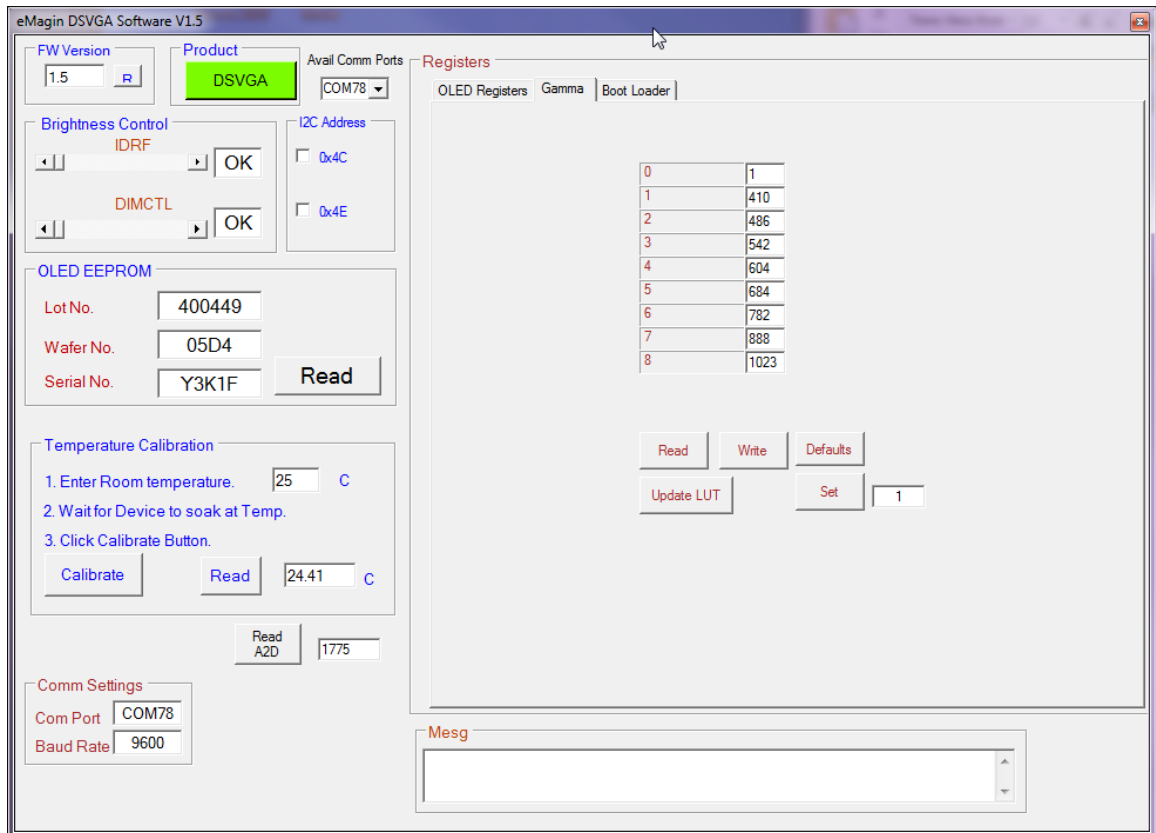

Figure 6-5 Gamma Section of the Software

6.6.1. Gamma Coefficients GC(0-8)

The 9 boxes in the Gamma section represent the 9 segment piece-wise-linear function that defines the gamma curve. These 9 values are used to calculate the 256 element look-up-table (LUT) that is required to transform input video data into a gamma-corrected data signal for the microdisplay input port. The “Read” button will retrieve the current 9 values from the microcontroller. The user can change any of the 9 values and see the resulting gamma corrected video by pressing the “Write” button.

6.6.2. Using “Update LUT” Button for Auto-Gamma Correction

The software allows for the immediate update of the gamma tables with the push of a button, “Update LUT”. This button, located in the center of the software form, tells the firmware to calculate the Gamma coefficients using the VGN signal provided by the DSVGA microdisplay. This feature allows the display gamma to be automatically adjusted for any operating conditions of temperature and brightness. The firmware calculates the 9 Gamma coefficients and then the full 256 value lookup table. This lookup table is then loaded, by the firmware, into the DSVGA Microdisplay.

6.6.3.Loading the LUT from a file

The software allows for the loading of the gamma tables from a text file. The format is as follows;

```
1
174
396
529
575
583
591
599
607
612
618
.
.
1023
```

Each of the 256 values is on a separate line. This lookup table is then loaded, by the firmware, into the display.

6.6.4.The “Read LUT” Button

The software allows for the reading of the full 256 values of the LUT using this button. The result is displayed in the message box at the bottom of the software. The user can scroll through all the values or select and save to a text file. These LUT values are the values before being gray-coded.

6.6.5.System Gamma

The software allows for the overall System Gamma to be set between 0.5 and 2.5 when using the Auto-Gamma feature. This System Gamma can be used to compensate for the gamma of the input video. For example, if the source video is gamma corrected to 2 then setting the System Gamma to 1.9 and pressing the “Set” button will give a better overall gamma response. This does not mean that there is a 1 to 1 relationship between input gamma and the System Gamma.

Figures 6-6 to 6-8 show the grayscale response for a display at several luminance settings obtained by using the “Update LUT” feature and the System Gamma set to 1.

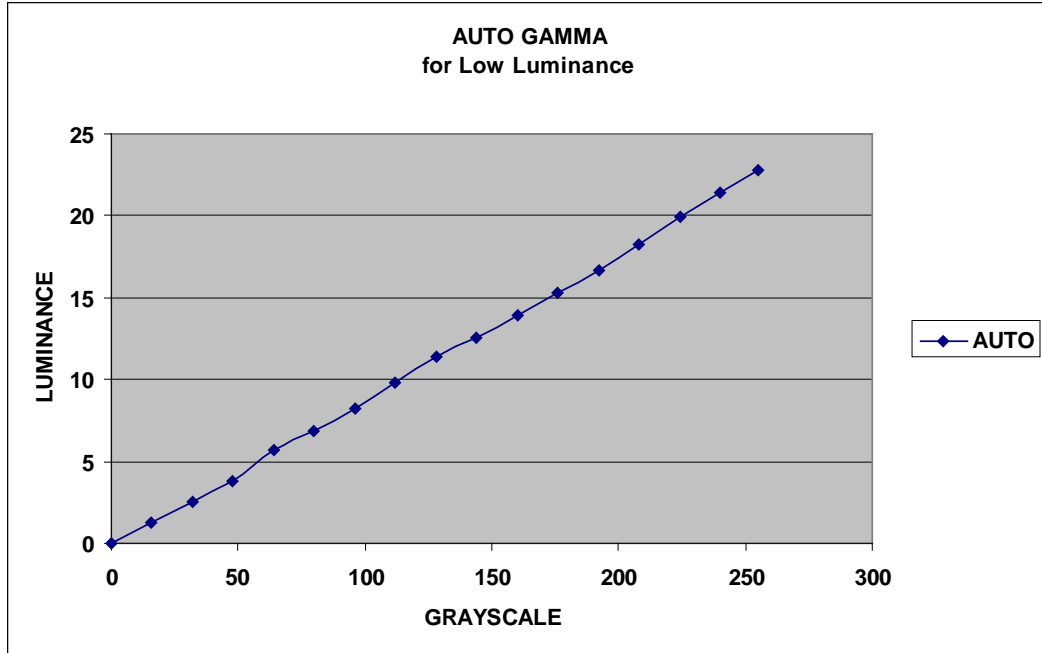

Figure 6-6 Luminance Response for Auto Gamma at Low Luminance

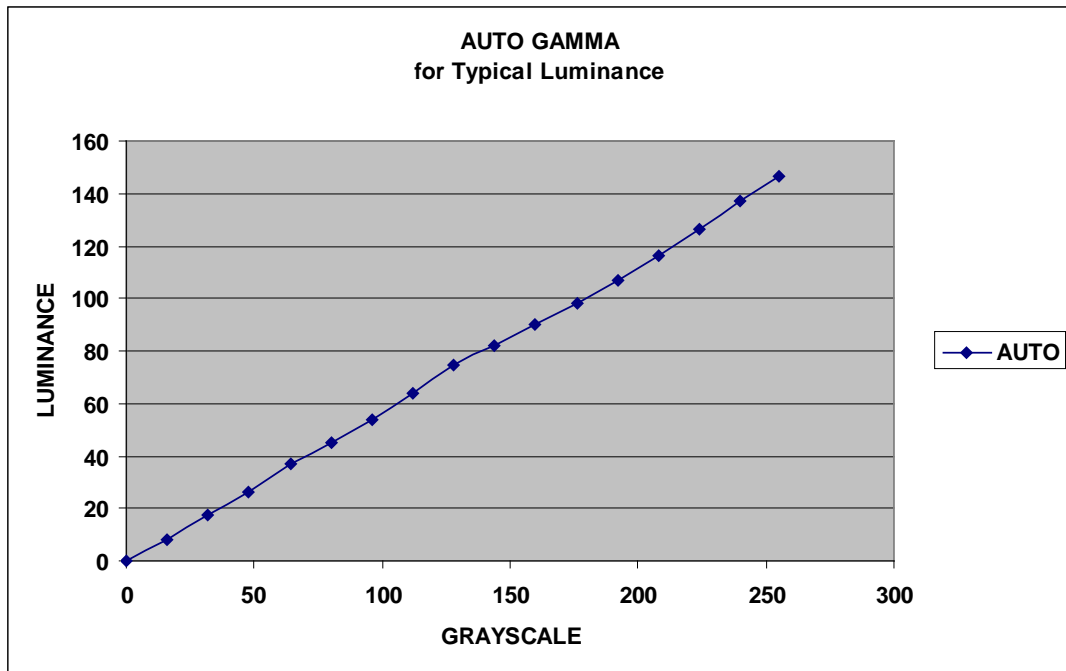

Figure 6-7 Luminance Response for Auto Gamma at Typical Luminance

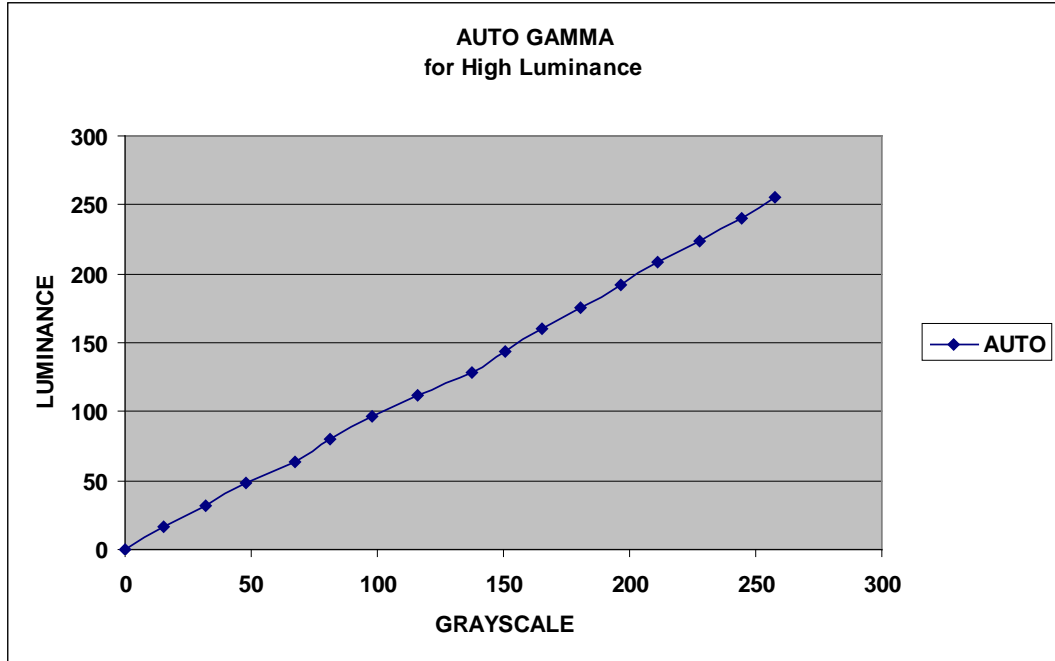

Figure 6-8 Luminance Response for Auto Gamma at High Luminance

7. REVISION HISTORY

Revision Level	ECN	Date	Description
0	2014-133	10/6/2014	Initial draft
1	2015-30	3/13/2015	Added commercial DRK part number (EMA-200015)