

SMT735

High Performance Infrared TOP IR LED

SMT735 consists of an AlGaAs LED mounted on the lead frame as TOP LED package and is 10mW typical of output power.

It emits a spectral band of radiation at 735nm.

◆ Specifications

1) Product Name	TOP IR LED
2) Type No.	SMT735
3) Chip	
(1) Chip Material	AlGaAs
(2) Peak Wavelength	735nm typ.
4) Package	
(1) Lead Frame Die	Silver Plated
(2) Package Resin	PPA Resin
(3) Lens	Epoxy Resin

◆ Outer dimension (Unit:mm)

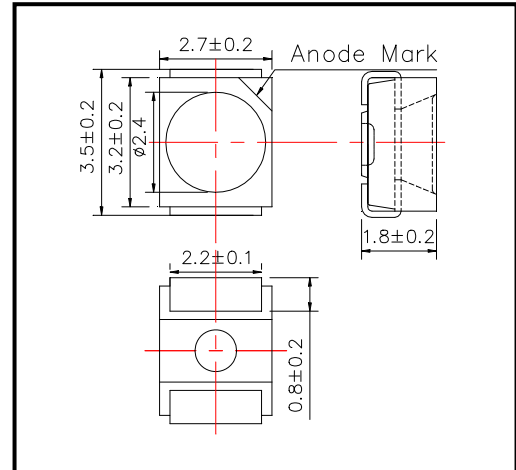

◆ Absolute Maximum Rating

Item	Symbol	Maximum Rated Value	Unit	Ambient Temperature
Power Dissipation	P _D	100	mW	T _a =25°C
Forward Current	I _F	50	mA	T _a =25°C
Pulse Forward Current	I _{FP}	200	mA	T _a =25°C
Reverse Voltage	V _R	5	V	T _a =25°C
Junction Temperature	T _J	100	°C	
Thermal Resistance	R _{thjp}	200	K/W	
Operating Temperature	T _{OPR}	-20 ~ +80	°C	
Storage Temperature	T _{STG}	-30 ~ +80	°C	
Soldering Temperature	T _{SOL}	250	°C	

‡Pulse Forward Current condition: Duty=1% and Pulse Width=10us.

‡Soldering condition: Soldering condition must be completed within 5 seconds at 250°C

◆ Electro-Optical Characteristics [T_a=25°C]

Item	Symbol	Condition	Minimum	Typical	Maximum	Unit
Forward Voltage	V _F	I _F =50mA		1.90	2.30	V
Reverse Current	I _R	V _R =5V			10	uA
Total Radiated Power	P _O	I _F =50mA	5.0	10.0		mW
Radiant Intensity	I _E	I _F =50mA	2.0	5.0		mW/sr
Peak Wavelength	λ _P	I _F =50mA		735		nm
Half Width	Δλ	I _F =50mA		20		nm
Viewing Half Angle	θ _{1/2}	I _F =50mA		±55		deg.
Rise Time	t _r	I _F =50mA		80		ns
Fall Time	t _f	I _F =50mA		80		ns

‡Total Radiated Power is measured by Photodyne #500

‡Radiant Intensity is measured by Tektronix J-6512.

◆ SMD Application
IR-Reflow Soldering Profile for lead free soldering

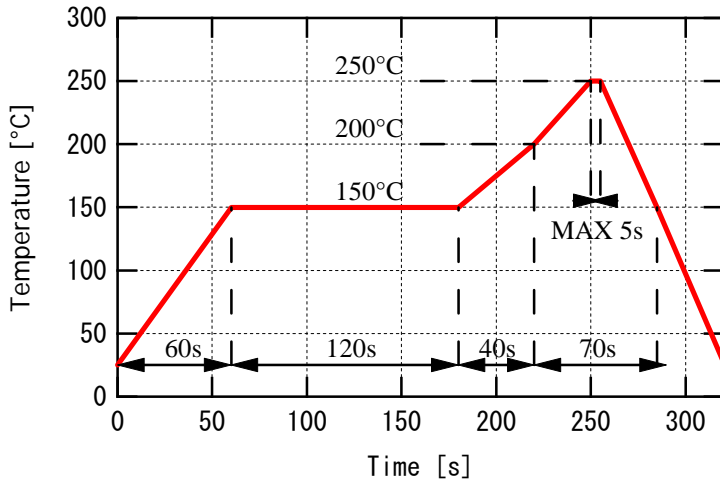

Recommended Land Layout (Unit: mm)

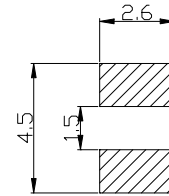

Don't put stress on SMD and a circuit board after soldering.

◆ SMD Packing
Tape and Reel Dimensions (Unit: mm)

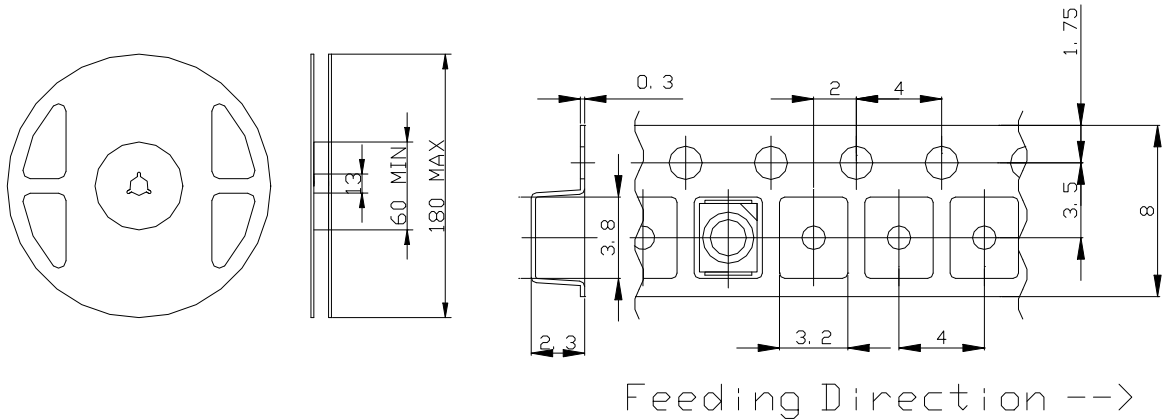

Feeding Direction -->

◆ Wrapping

Moisture barrier bag aluminum laminated film with a desiccant to keep out the moisture absorption during the transportation and storage.