

Burners

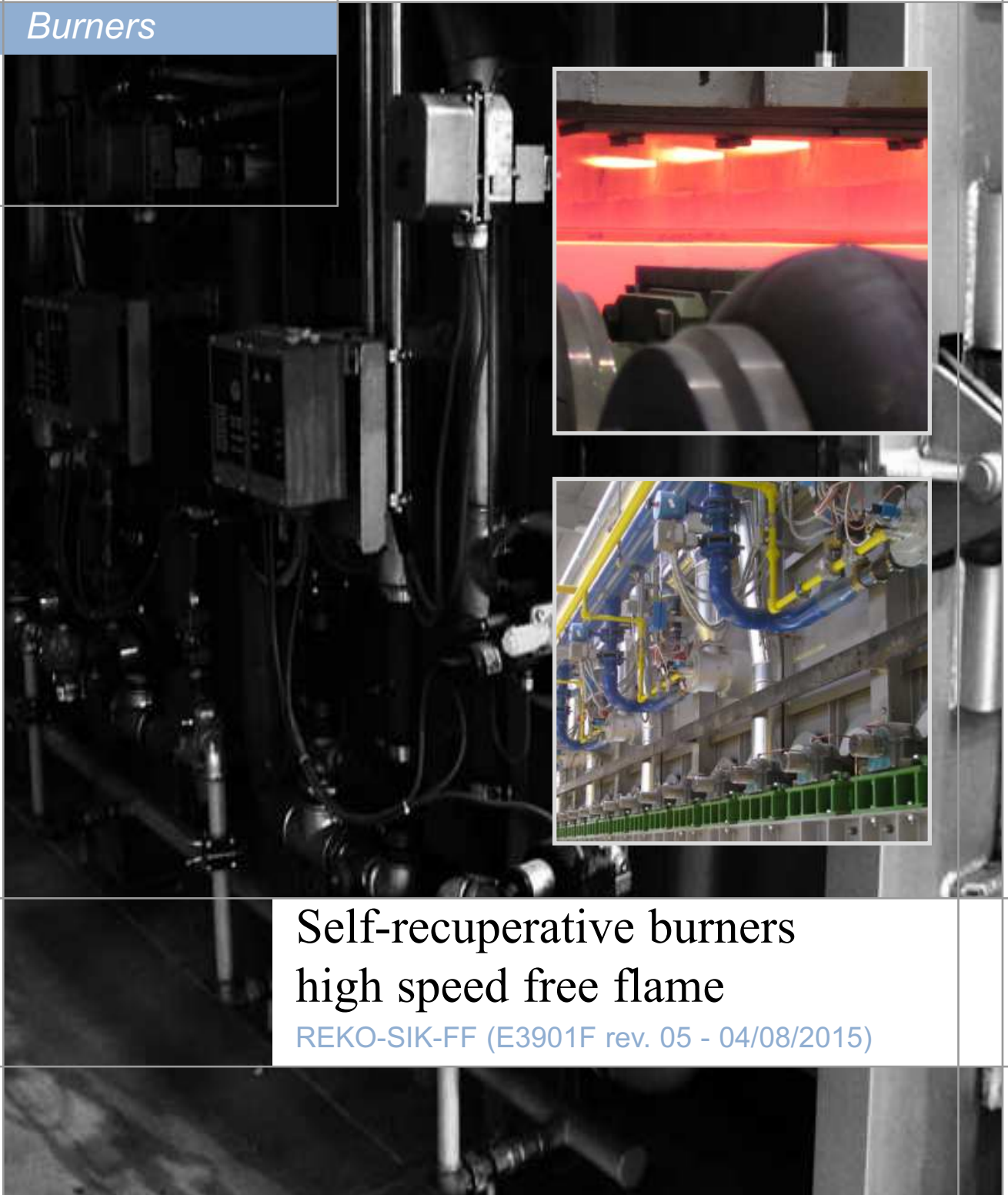

Self-recuperative burners  
high speed free flame

REKO-SIK-FF (E3901F rev. 05 - 04/08/2015)

## GENERAL WARNINGS:



■ All installation, maintenance, ignition and setting must be performed by qualified staff, respecting the norms present at the time and place of the installation.

■ To avoid damage to people and things, it is essential to observe all the points indicated in this handbook. The reported indications do not exonerate the Client/User from observing general or specific laws concerning accidents and environmental safeguarding.

■ The operator must wear proper DPI clothing (shoes, helmets...) and respect the general safety, prevention and precaution norms.

■ To avoid the risks of burns or high voltage electrocution, the operator must avoid all contact with the burner and its control devices during the ignition phase and while it is running at high temperatures.

■ All ordinary and extraordinary maintenance must be performed when the system is stopped.

■ To assure correct and safe use of the combustion plant, it is of extreme importance that the contents of this document be brought to the attention of and be meticulously observed by all personnel in charge of controlling and working the devices.

■ The functioning of a combustion plant can be dangerous and cause injuries to persons or damage to equipment. Every burner must be provided with certified combustion safety and supervision devices.

■ The burner must be installed correctly to prevent any type of accidental/undesired heat transmission from the flame to the operator or the equipment.

■ The performances indicated in this technical document regarding the range of products are a result of experimental tests carried out at ESA-PYRONICS. The tests have been performed using ignition systems, flame detectors and supervisors developed by ESA-PYRONICS. The respect of the above mentioned functioning conditions cannot be guaranteed if equipment, which is not present in the ESA-PYRONICS catalogue, is used.

## DISPOSAL:



To dispose of the product, abide by the local legislations regarding it.

## GENERAL NOTES:



■ In accordance to the internal policy of constant quality improvement, ESA-PYRONICS reserves the right to modify the technical characteristics of the present document at any time and without warning.

■ It is possible to download technical sheets which have been updated to the latest revision from the **www.esapyronics.com** website.

■ The REKO-SIK-FF products have been designed, manufactured and tested according to the most correct construction practices and following the applicable requirements described in **UNI EN 746-2-2010** 'Industrial heating process equipment - Part 2: Safety requirements for combustion and for the handling and processing of fuels'. We emphasize that the burners described in this data sheet **are provided as independent units and are excluded from the scope of the Machine Directive 2006/42/EC** not having any mobile items that are not exclusively manual.

■ Certified in conformity with the **UNI EN ISO 9001** Norm by DNV GL.

## CERTIFICATIONS:



The products conform to the requests for the Euroasia market (Russia, Belarus and Kazakhstan).

## CONTACTS / SERVICE:



### Headquarters:

Esa S.p.A.  
Via Enrico Fermi 40  
24035 Curno (BG) - Italy  
Tel +39.035.6227411  
Fax +39.035.6227499  
[esa@esacombustion.it](mailto:esa@esacombustion.it)

### International Sales:

Pyronics International s.a.  
Zoning Industriel, 4ème rue  
B-6040 Jumet - Belgium  
Tel +32.71.256970  
Fax +32.71.256979  
[marketing@pyronics.be](mailto:marketing@pyronics.be)

[www.esapyronics.com](http://www.esapyronics.com)

REKO-SIK-FF are self - recuperative gas burners for direct heating. These burners use combustive fumes to preheat the combustive air. Depending on size and conditions of use, this type of burner guarantees a substantial reduction in consumption compared to traditional burners.

## APPLICATIONS

- Furnaces with fibre covering.
- Ceramic or treatment furnaces.
- Tunnel or chariot furnaces.
- Furnaces with continuous or discontinuous function.
- Furnaces with pulse-firing burner control.



F3901F03

## CHARACTERISTICS

### GENERAL:

- Capacity: from 30 to 400 kW
- Functions with various types of gas: CH<sub>4</sub>/LPG/Propane/etc.
- Maximum furnace temperature: 1350 °C
- Burner inlet air pressure: 70 mbar
- Burner inlet gas pressure: 70 mbar
- Inlet air temperature: environment
- Preheated air temperature: up to 750 °C
- Potential ratio: 1:5
- Flame velocity: up to 140 m/s
- Low NO<sub>x</sub> e CO emission
- Highly efficient ejector to evacuate 100% of the fumes emitted during combustion.

### MATERIAL COMPOSITION:

- Exhaust air-inlet body: AISI304
- Gas collector pipe: Cast Iron G25
- Exchange tube: AD-SIC
- Combustion head: INCOLOY601/AISI310S
- Exhaust guiding spacer: AISI304/FL35
- Surface treatment: galvanization, steel pickling, high temperature painting



F3901F04

## CAPACITY AND FLAME LENGTH PARAMETERS

The REKO-SIK-FF ignition takes place through a high tension discharge, which is carried out by a WAND electrode. The flame is detected via a uv-scanner (not included).

The adoption of flame controls is highly recommended in all systems operating at temperatures below 750°C (UNI EN746-2 Norm).

Model	Capacity kW	Flame length mm	Flame velocity (m/s)	Ignition	Detection
REKO-1-SIK-FF	30	200 ÷ 300	140	WAND-EN	UV-2
REKO-2-SIK-FF	60	300 ÷ 400	140	WAND-EN	UV-2
REKO-3-SIK-FF	100	400 ÷ 500	140	WAND-EN	UV-2
REKO-4-SIK-FF	170	600 ÷ 800	120	WAND-EN	UV-2
REKO-5-SIK-FF	240	800 ÷ 1000	120	WAND-EN	UV-2
REKO-6-SIK-FF	400	1200 ÷ 1500	120	WAND-EN	UV-2

## DESCRIPTION

The REKO-SIK-FF burners use the temperature exhaust fumes to preheat the combustive air, thus saving more energy and reducing atmospheric pollution.

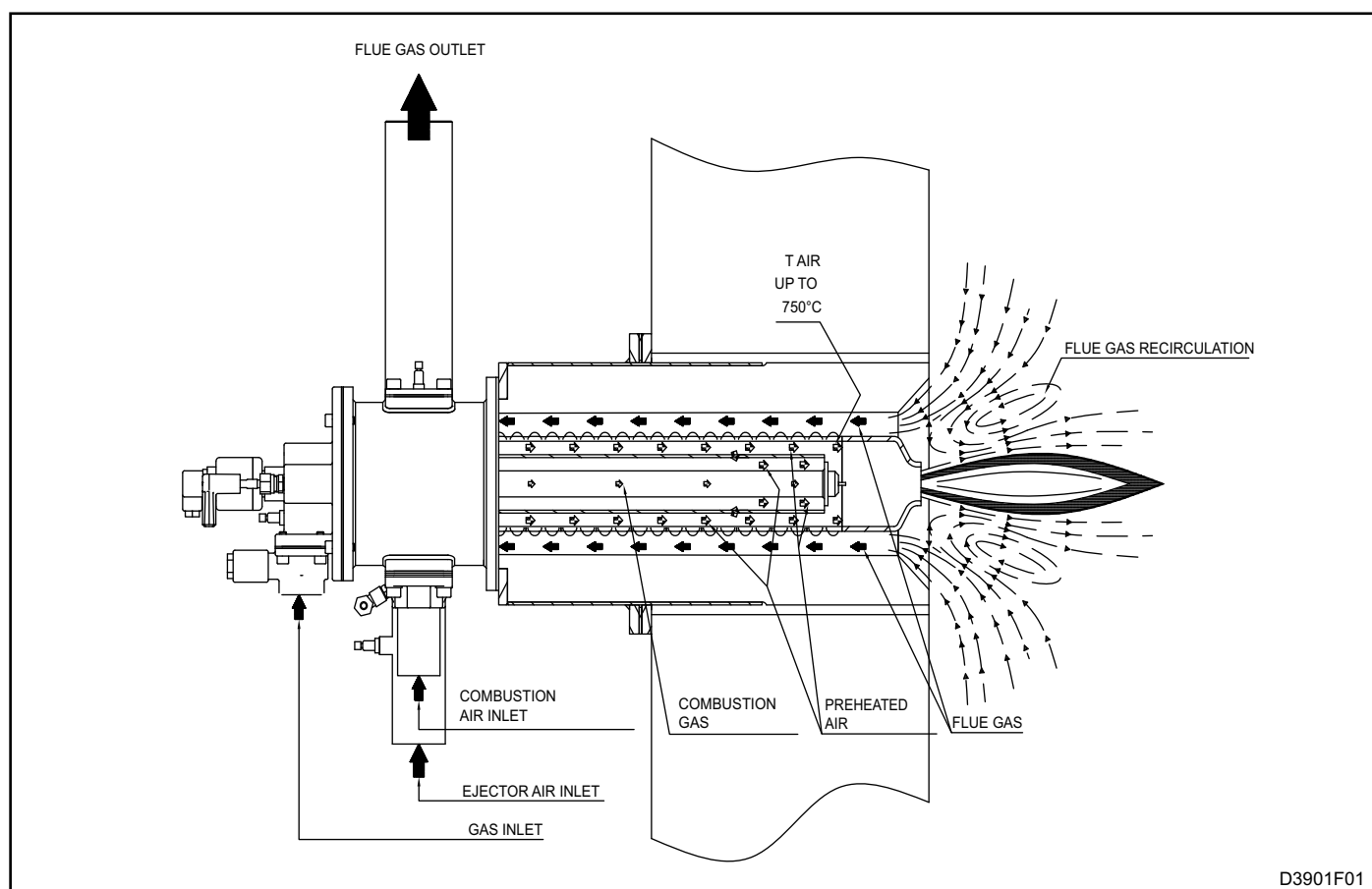

The choice of materials has been made according to the burners' performance. Furthermore, the stainless steel exhaust-air inlet body, assures a high resistance to heat and oxidation. The heat exchanger element is made of silicon carbide and its special conformation allows the

optimization of heat transfer from the combustion products to the combustive air. This choice allows the burner to be used with maximum chamber temperature of up to 1300°C under direct heating conditions.

Multistage combustion technology, together with the recycling of combustive gases, guarantees low NOx and CO emissions, despite the preheating air temperature value of up to 750°C. The REKO-SIK-FF are compact burners with reduced weight and size. They have separate gas and air inlets, nozzle mixers (no flashbacks) and include:

micrometric gas adjuster, spark electrode, peep sight, gas calibrated orifice flow meter, furnace wall spacer and flue gas ejector. The suggested functioning is with MIN/MAX or ON/OFF and the setting is simplified by special pressure inlets on the air and gas side.

## BURNER PERFORMANCES

The flame capacity, length and velocity concern natural gas burners (8600 Kcal/Nm<sup>3</sup>), placed in a combu-

stion chamber with zero pressure and at sea level, which can function with 10% of excess air.

- MIN/MAX (ON/OFF) functioning
- Chamber temperature 1100°C
- NOx < 350 mg/Nm<sup>3</sup> [O<sub>2</sub> = 3% ref.]

### MAXIMUM CAPACITY

Free flame application			Burner model					
			REKO-1	REKO-2	REKO-3	REKO-4	REKO-5	REKO-6
Maximum power	SiC recuperator length	[mm]	605	630	635	635	750	800
	<b>Burner capacity (2% O<sub>2</sub>)</b>	<b>[kW]</b>	<b>30</b>	<b>60</b>	<b>100</b>	<b>170</b>	<b>240</b>	<b>400</b>
	Burner air flow	[Nm <sup>3</sup> /h]	33	66	110	187	264	440
	Ejector air flow	[Nm <sup>3</sup> /h]	43	86	143	243	343	570
	Total air flow (burner air + ejector air)	[Nm <sup>3</sup> /h]	76	152	253	430	607	1010
	Gas flow	[Nm <sup>3</sup> /h]	3	6	10	17	24	40
	Burner air inlet pressure	[mbar]	51.2	52	50.8	51.4	45	50
	Ejector air inlet pressure	[mbar]	65.2	65	65	69	62.8	65
	Δp flange gas measurement	[mbar]	10	10	10	9.7	10	10

### MINIMUM CAPACITY

Free flame application			Burner model					
			REKO-1	REKO-2	REKO-3	REKO-4	REKO-5	REKO-6
Minimum power	<b>Burner capacity (2% O<sub>2</sub>)</b>	<b>[kW]</b>	<b>6</b>	<b>12</b>	<b>20</b>	<b>45</b>	<b>60</b>	<b>80</b>
	Burner air flow	[Nm <sup>3</sup> /h]	6.6	13.2	22	49.5	66	88
	Ejector air flow	[Nm <sup>3</sup> /h]	8.6	17.2	28.6	64.4	85.5	114
	Total air flow (burner air + ejector air)	[Nm <sup>3</sup> /h]	15.2	30.4	50.6	113.9	151.5	202
	Gas flow	[Nm <sup>3</sup> /h]	0.6	1.2	2	4.5	6.0	8.0
	Burner air inlet pressure	[mbar]	4	4.5	3.4	5.6	2.3	2.5
	Ejector air inlet pressure	[mbar]	7	6.7	8	7.6	9.4	7.6
	Δp flange gas measurement	[mbar]	0.4	0.4	0.4	0.8	0.4	0.4

**EFFICIENCY TABLES**

**Permanent operation (100% Fire)**

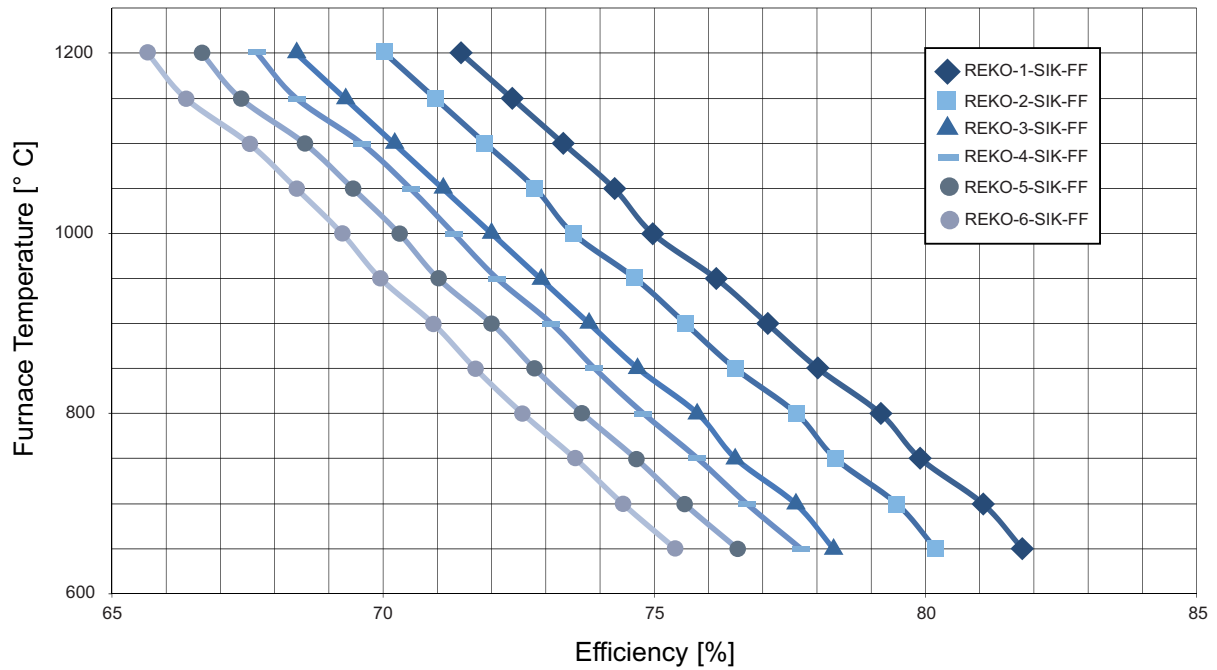

G3901FF01

**Permanent operation (100% Fire)**

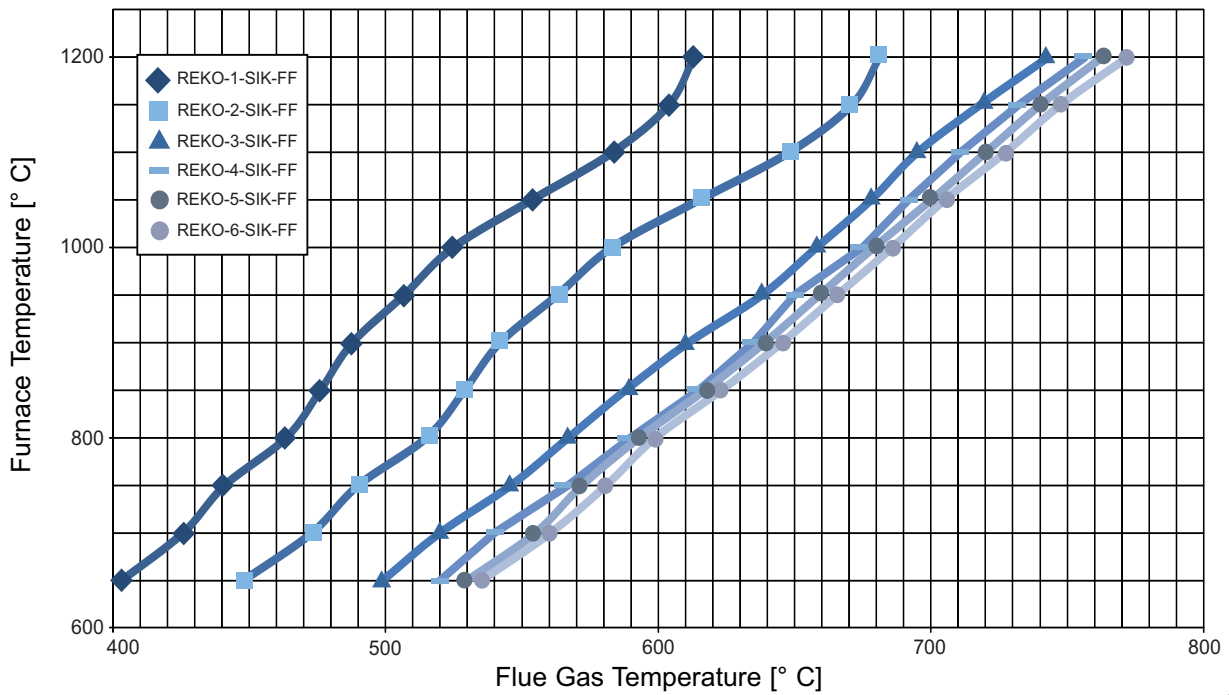

G3901F02

**EFFICIENCY TABLES**

**Permanent operation (100% Fire)**

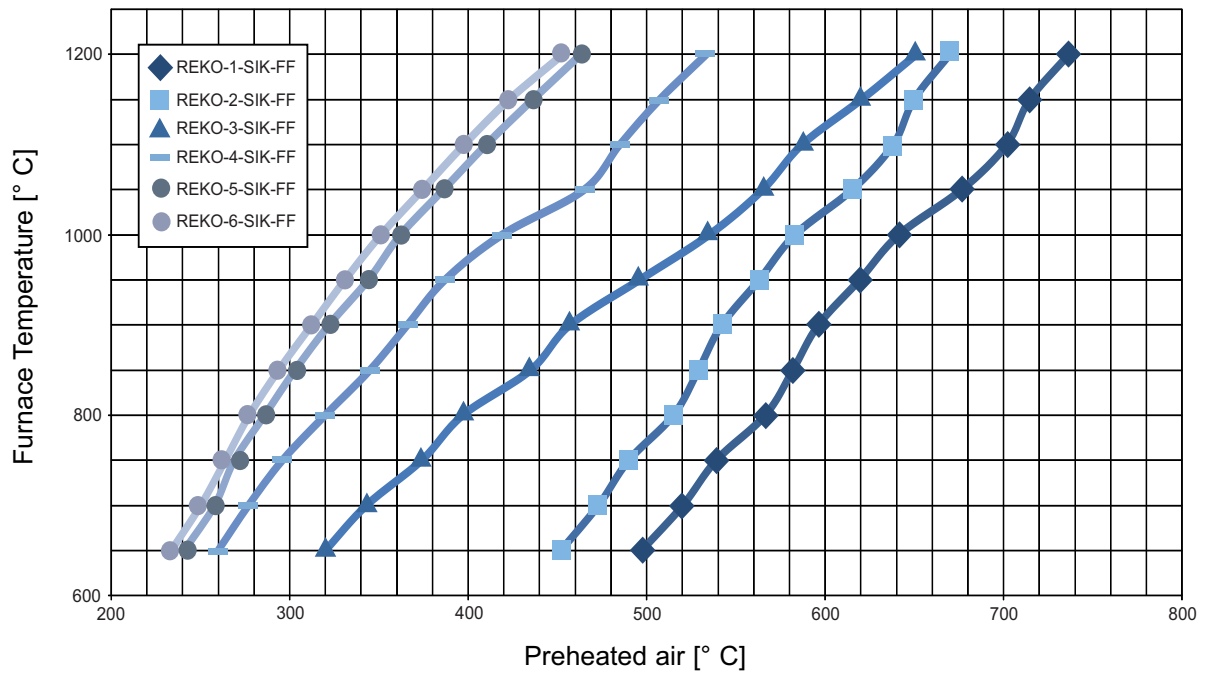

G3901F03

**FLOW SCHEME - FREE FLAME BURNER**

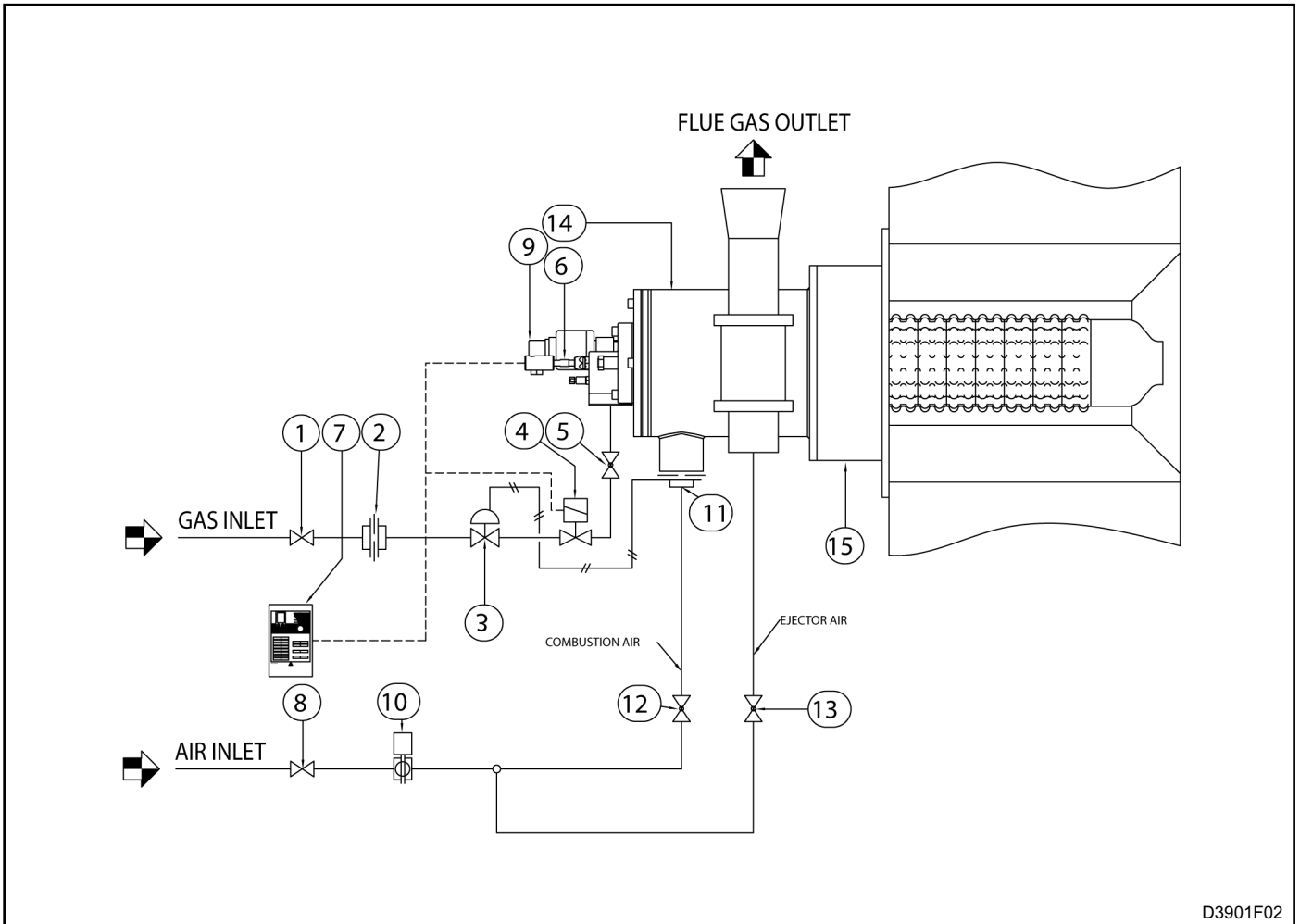

D3901F02

Pos.	Description	Included	Not Included
1	Gas ball valve		<b>X</b>
2	Gas calibrated flange	<b>X</b>	
3	Pressure regulator		<b>X</b>
4	Safety solenoid valve		<b>X</b>
5	Throttle valve	<b>X</b>	
6	Ignition electrode	<b>X</b>	
7	Flame control		<b>X</b>
8	Air ball valve		<b>X</b>
9	Uv-scanner for flame detection		<b>X</b>
10	Regulation valve		<b>X</b>
11	Combustion air orifice flow meter	<b>X</b>	
12	Combustion air gate valve	<b>X</b>	
13	Ejector air gate valve	<b>X</b>	
14	Self-recuperative burner	<b>X</b>	
15	Furnace wall adapting spacer	<b>X</b>	



## WARNINGS

- The REKO-SIK-FF burner series is intended for fixed installations. If mobile installations are needed (bell furnaces, etc...) it is necessary to preventively take into consideration the possibility of damage to hoses in silicon carbide, which is determined by the movement of the actual furnace.
- The burner must always be turned on at minimum power, then modulating towards the maximum, facilitating ignition and reducing exit overpressure.
- The passing from minimum power to maximum power must always be done gradually and not instantaneously. To do this, the use of two-phase MRBV air regulation valves is suggested.
- For all applications at low temperature (up to 750°C), burner ignition and the control of solenoid gas valves must be accomplished using a certified burner control device.
- To avoid possible damage to the burners, make sure that the blower does not send them hot or foul air (from combustion products, oils, solvents or other). To avoid this from occurring, install the blower or the air suction duct outside the establishment and far from the exhaust pipes.
- Check that the power lines are properly connected after the installation. Check the correct air and gas pressures (pag. 5).
- The burner can only work within the indicated power ranges. The functioning with less or more power can compromise the correct functioning and life span of the actual burner. In this case the general warranty conditions will not be applicable anymore and ESA-PYRONICS will not be held responsible for any damage caused to persons or things.
- If there is trouble with other devices during the burner start up phase, use the connector with anti disturbance filter for the high-tension (HT) cable connection of the ignition electrode.
- Avoid burner ignition close to each other so as not to heat the ignition command system devices (solenoid valves and transformers). Prewash time lapse + first safety time lapse + min. of 5 sec. = time lapse between one ignition and another. (however, do not attempt more than 2 ignitions during a 30sec. time lapse).
- Make sure the power supply is TURNED OFF when intervening on the burner and its devices. In case of burner malfunctioning, follow the indications in the 'Maintenance' chapter of the present manual or contact ESA-PYRONICS assistance.
- Any modification or repair done by third parties can compromise the application safety and automatically cause the general warranty conditions to expire.

## INSTALLATION

The REKO-SIK-FF burners are provided with a special furnace wall adapting spacer. The lodging of the burner and its spacer must provide free space around the burner, which has to subsequently be packed with refractory material such as ceramic fibre (see pag.16).

Cautiously follow the indications below for the installation:

- 1** - Place REKO burners far from heat sources and products like: liquids, solvents or corrosive gases.
- 2** - Make sure the dimensions of the lodging and distance between the stoking pipes and the exhaust pipes correspond to those specified in the 'Overall Dimensions' chapter pag. 16.
- 3** - Assemble the spacer on the walls of the furnace (**pos. 01**) interposing ceramic fibre gaskets between the flanges (**pos. 02**). During this phase make sure that the external insulation wrapping does not get altered or damaged. Once the spacer is fitted to the wall, from the inside of the combustion chamber, seal all possible cracks that are left between the wall and the spacer with refractory ceramic material.
- 4** - Insert the burner (**pos. 03**) into the spacer, interposing ceramic fibre gaskets (**pos. 04**), making sure that the correct positioning of the air and gas inlets as well as the exhaust pipe have been checked. During this procedure it is necessary to pay close attention to avoid rupturing or damage of the silicon carbide flame tube (**pos. 05**).
- 5** - Fit the ejector/chimney assembly at the exhaust outlet (**pos. 06**). The use of open natural draught hoods is advised so as to avoid exhaust fume pressure, which in turn can create conditions of stress and malfunctioning for the burner.
- 6** - Assemble the pre-installation of the combustion air lines and ejector (**pos. 07**) through the rubber compensators (**pos. 10**) that must then be shut via the appropriate collars.
- 7** - Connect the burner air and gas inlet tubes, interposing, if possible, dilation joints in AISI.
- 8** - To the uv-detecting spacer (**pos. 08**), on the predisposed inlet for the cooling process, connect a hose of  $\varnothing$  8mm with relative fitting. This must carry fixed air for the cooling process of the sensor.
- 9** - Connect electricity to the ignition electrode and to the uv-scan detector making sure not to pass the conductors near heat sources.
- 10** - Check to see that the burner body and all its metallic elements are earthed with appropriate conductors.
- 11** - The connecting cable from the ignition transformer to the electrode must be specific for high tension and not screened. It must not be more than 1 meter long; otherwise the ignition transformer must be positioned near the burner. The high tension cable must be placed far from the power cables and not in metallic ducts. Ideally it should be left in open air.

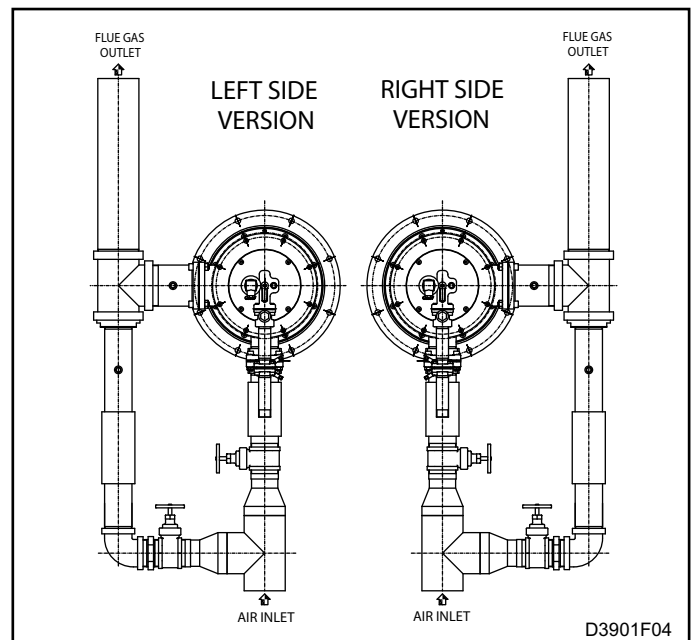
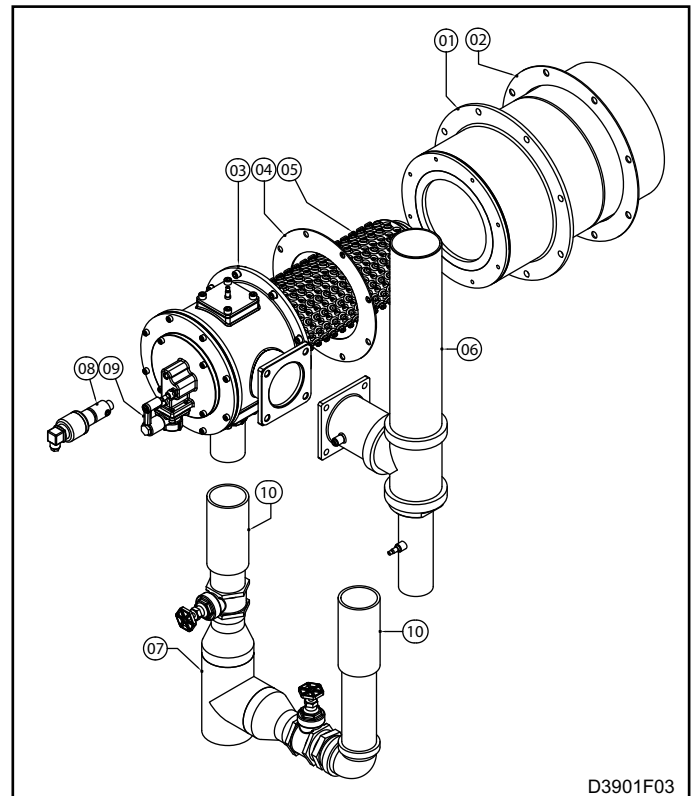

**NB: gas insertion may be supplied on request.**

For more information refer to the technical sheet concerning ignition transformers.

## START UP AND SETTING

The procedures indicated in the following chapter must be carried out by expert technicians. The non-observance of the instructions given can provoke dangerous conditions.

**1** - Check that the combustion air pressure exiting the blower and the combustive fuel pressure are both within the allowed range.

**2** - Adjust the working pressure and the safety device pressure of the combustion plant, whether there is one per burner or one for the whole plant i.e. gas pressure reduction gear, block valve, relief valve, pressure switches etc. Simulate the intervention of all the safety devices including the intervention of the safety over temperature, checking that the fuel safety block devices act properly.

**3** - Place the air regulation valve in the maximum opening position and adjust the burner and ejector inlet air pressure, via the gate valve. This must be done referring to the values indicated in the 'Burner Performances' chapter for the maximum power pag.05.

**4** - Place the air regulation valve in the minimum opening position and adjust its opening to obtain (in burner and ejector inlet) the relative minimum power pressure.

**5** - Activate the burner control device and attempt the ignition until the burner switches on. While attempting to ignite the burner, act on the gas adjustment valve and, starting from the totally closed position, open it gradually until the burner ignites.

**6** - Fully open the air regulation valve and adjust, via the gas adjustment valve, the maximum fuel capacity, checking the differential pressure created on the calibrated gas flange.

**7** - Double check that, at minimum and maximum power, the burner and ejector inlet pressures correspond to the values in the in the 'Burner Performances' chapter. These values may be different depending on whether the burner is on or off.

**8** - If necessary, with all burners turned onto the same power, analyze the combustion products in the chamber (where possible) or exiting each burner (on the exhaust muff).

**9** - Repeatedly attempt ignition at minimum burner power, with maximum amplitude, to check the ignition reliability and flame stability during the adjustment.

**NATURAL GAS CAPACITY TABLE - REKO-SIK-FF**

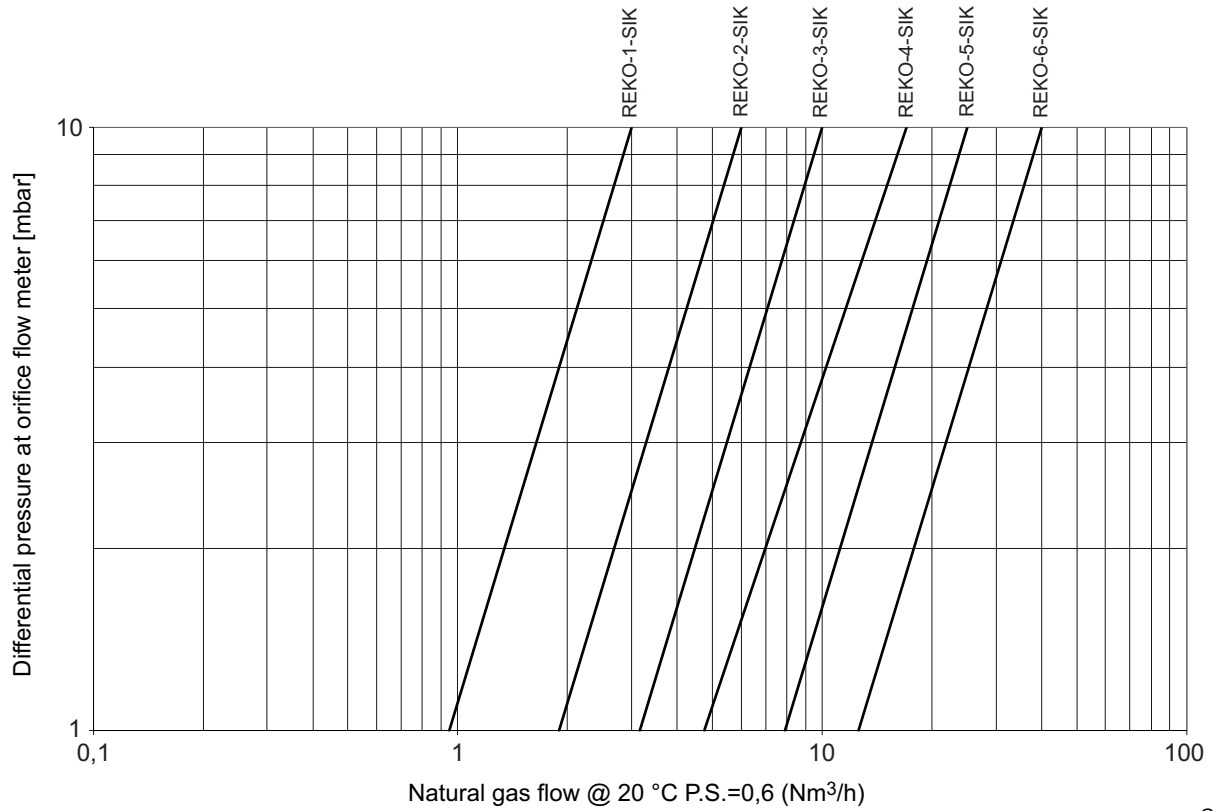

G3901F04

**AIR CAPACITY TABLE - REKO-SIK-FF**

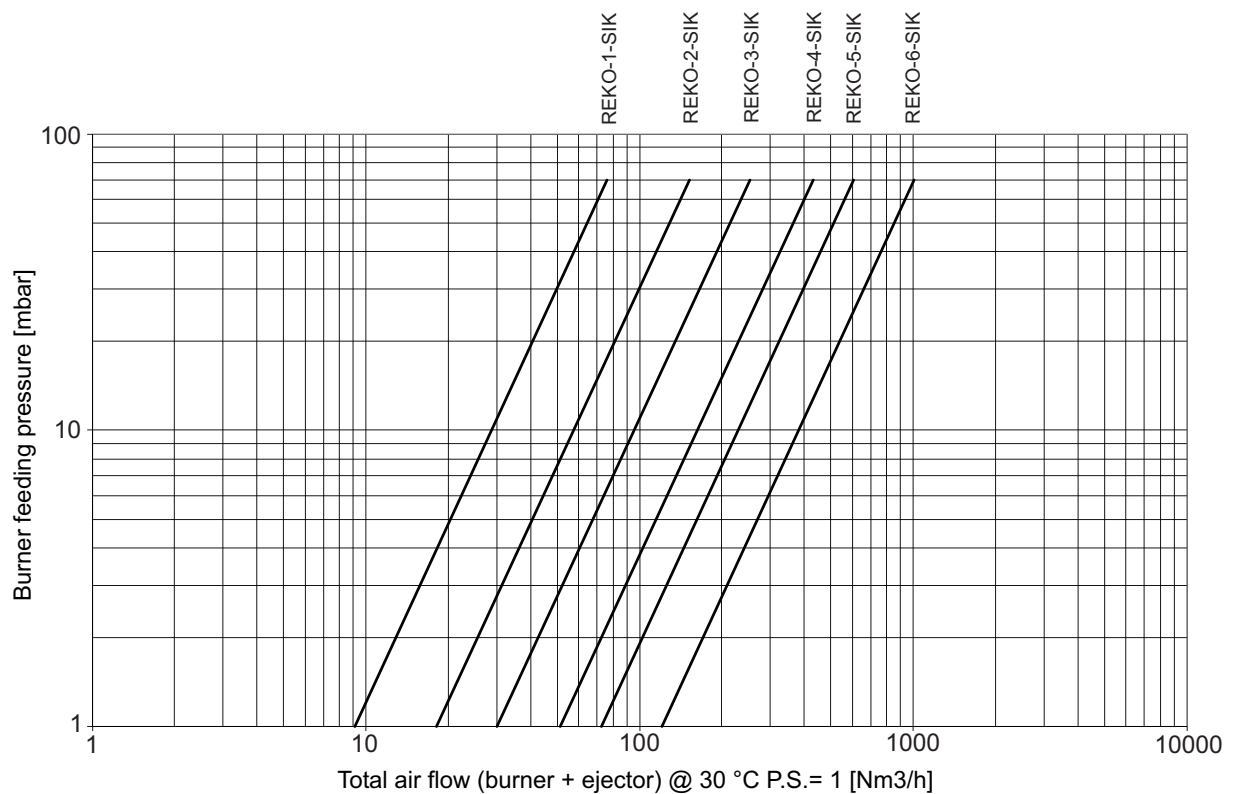

G3901F05

## GENERAL MAINTENANCE PLAN

Operation	Type	Advised time	Notes
<b>High tension electrode connection</b>	O	annual	check integrity of outer plastic and oxidization of internal electrode terminal
<b>Electrode ignition</b>	O	annual	replace if the kantal terminal is worn
<b>Flexible rubber joints in air line</b>	S	every semester	check that there are no leaks nor vulcanized rubber
<b>Fume guiding tube spacer integrity</b>	S	annual	at every maintenance check with furnace turned off, from the inside, make sure there are no cracks in the refractory material
<b>SiC heat exchanger integrity</b>	S	annual	at every maintenance check with furnace turned off, from the inside, make sure there are no cracks in the refractory material
<b>Cleaning of uv-scanner watch glass</b>	O	every semester	reduce to a quarterly check in dusty environments.
<b>Uv-scanner replacement</b>	O	10.000 h of functioning	in any case every 2 years
<b>Replacement of ejector gaskets (*)</b>	S	annual	to be done only when the furnace is off and cold.
<b>Replacement of gas side gaskets (**)</b>	S	annual	see note
<b>Burner setting</b>	O	annual	repeat the steps in the 'IGNITION AND SETTING' section on page 11

**NOTES:**

Caption: O = ordinary / S = extraordinary

(\*) it is suggested that the gaskets on the gas side are replaced after every disassembly of the gas feeding line.

(\*\*) use high temperature gaskets

## ORDINARY MAINTENANCE

For correct dismantling and better maintenance of the REKO-SIK-FF burners, meticulously follow the instructions below with the plant turned off.

### CLEANING OF UV-SCANNER WATCH GLASS

**1** - Check that the burner control device is not connected.  
**2** - Disconnect power supply to the uv-scanner (**pos. 01**) and the cooling line (where present **pos. 07**).  
**3** - Unscrew the aluminium pipe fitting (**pos. 06**) at the base of the gas collector, removing the uv-scanner with its spacer.

**4** - Unscrew the aluminium fitting from the insulation teflon connector (**pos. 03**) and remove the quartz watch glass (**pos. 05**).

**5** - Clean the quartz watch glass with a damp cloth and proceed to reassemble everything making sure that both the glass as well as the gaskets are put back in the correct positions (**pos. 04**) between the aluminium teflon spacer, before tightening.

**6** - Restore the cooling hoses and power connection.

**7** - Check the correct flame detection of the uv-scanner.

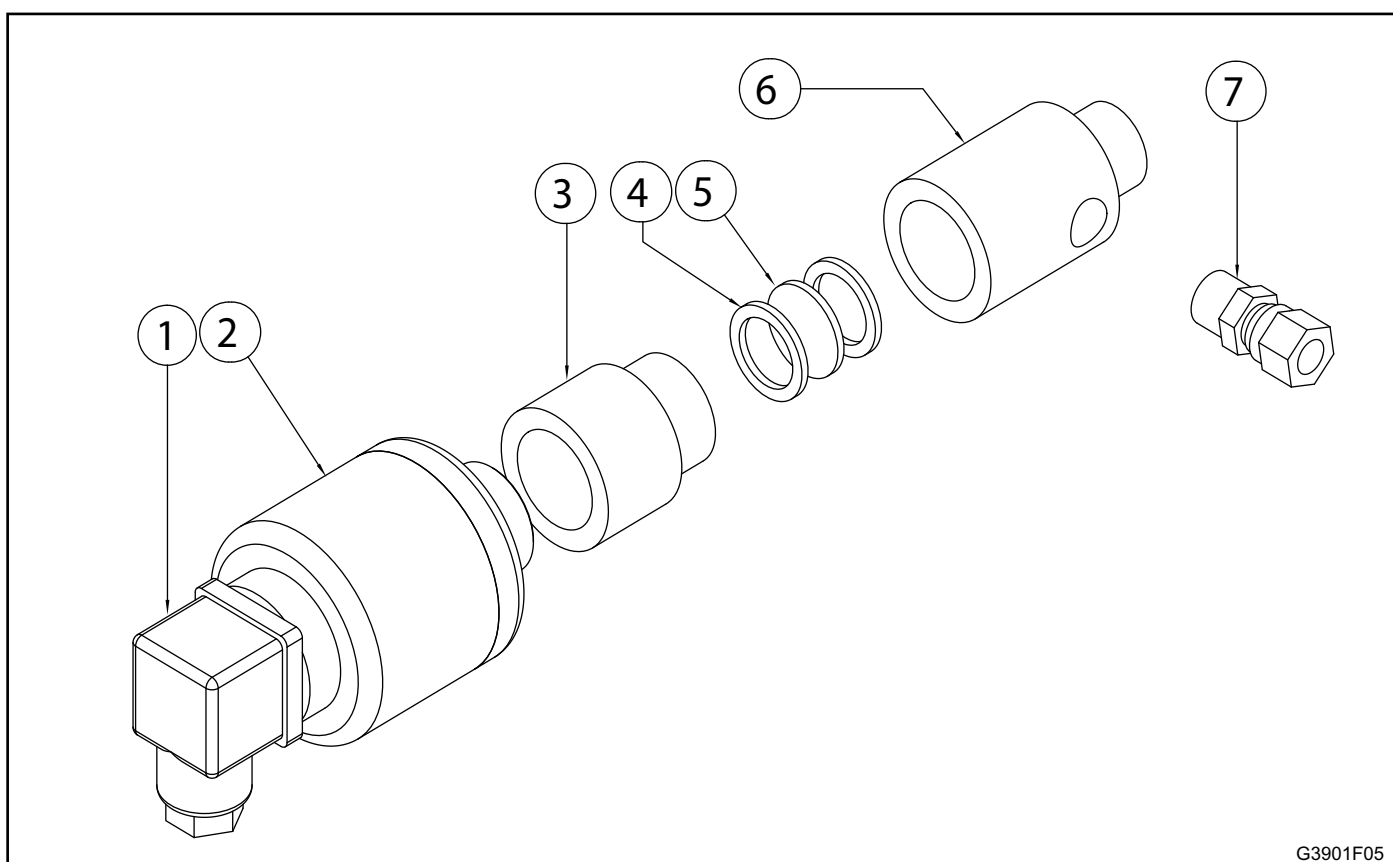

G3901F05

## EXTRAORDINARY MAINTENANCE

For correct dismantling and better maintenance of the REKO-SIK -FF burner, meticulously follow the instructions below with the plant turned off.

### BURNER SHUTDOWN

**In shutdown conditions of the burner refer to the burner control device indications and to the relative manual to identify the cause. The main cases are indicated here below:**

■ **Illegal flame detection:** the shutdown is due to an illegal flame detection during the phases prior to ignition or after the turning off. The causes are within the detection system (broken or faulty sensor or presence of humidity), or in the gas draw from the electric safety valve, which allows the burner to remain turned on.

■ **Failed ignition:** shutdown is caused by the fact that no flame has been created during the starting process. The causes can be found in the start up system (spark absence, faulty electrodes or incorrect position), in the bad setting of the fuel and combustion flow or in the detection system (faulty sensor or interrupted cables). More precisely, in the first two cases the flame is not ignited, while in the last case the flame is created but the burner control device is unable to detect it.

■ **Flame signal loss:** shutdown due to the loss of flame signal during the normal functioning of the burner. The causes can be found in the combustion air flow adjustment (rapid flow variations, adjustment out of allowed range). They can also be found in the detection system (faulty, dirty or badly positioned sensors).

### UV-SCANNER REPLACEMENT

- 1 - Check that the burner control device is not connected.
- 2 - Disconnect the electrical flow to the uv-scanner (**pos. 01**) and to the cooling line (where present).
- 3 - Unscrew the aluminium pipe fitting at the base of the gas collector (**pos. 02**), removing the uv-scanner with its spacer.
- 4 - Screw the new component back on, in the same position, after having checked the correct position of the watch glass insulation between the aluminium and teflon spacers.
- 5 - Restore the cooling pipes and the electrical connection.
- 6 - Check the correct uv-scanner flame detection.

### IGNITION ELECTRODE REPLACEMENT

- 1 - Check that the burner control device is not connected.
- 2 - Disconnect the Ht cable, by disconnecting the electrode insulation connector (**pos. 06**).
- 3 - Unscrew the upper connector (**pos. 03**) and then extract the retaining spring (**pos. 04**) and the electrode (**pos. 05**).
- 4 - Insert the new electrode, checking its beat. Place the retaining spring back inside and completely screw the connector back on again.
- 5 - Reconnect the electrode insulation connector. Replace it if necessary.

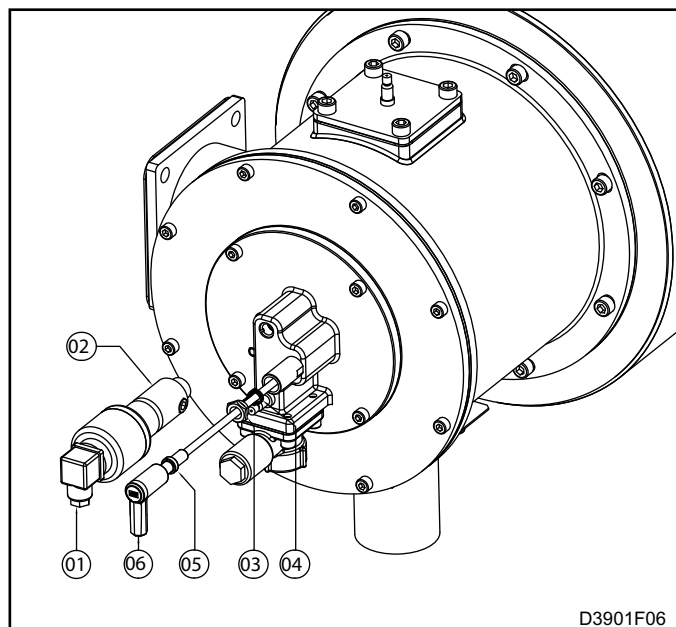

**OVERALL DIMENSIONS - REKO-SIK-FF**

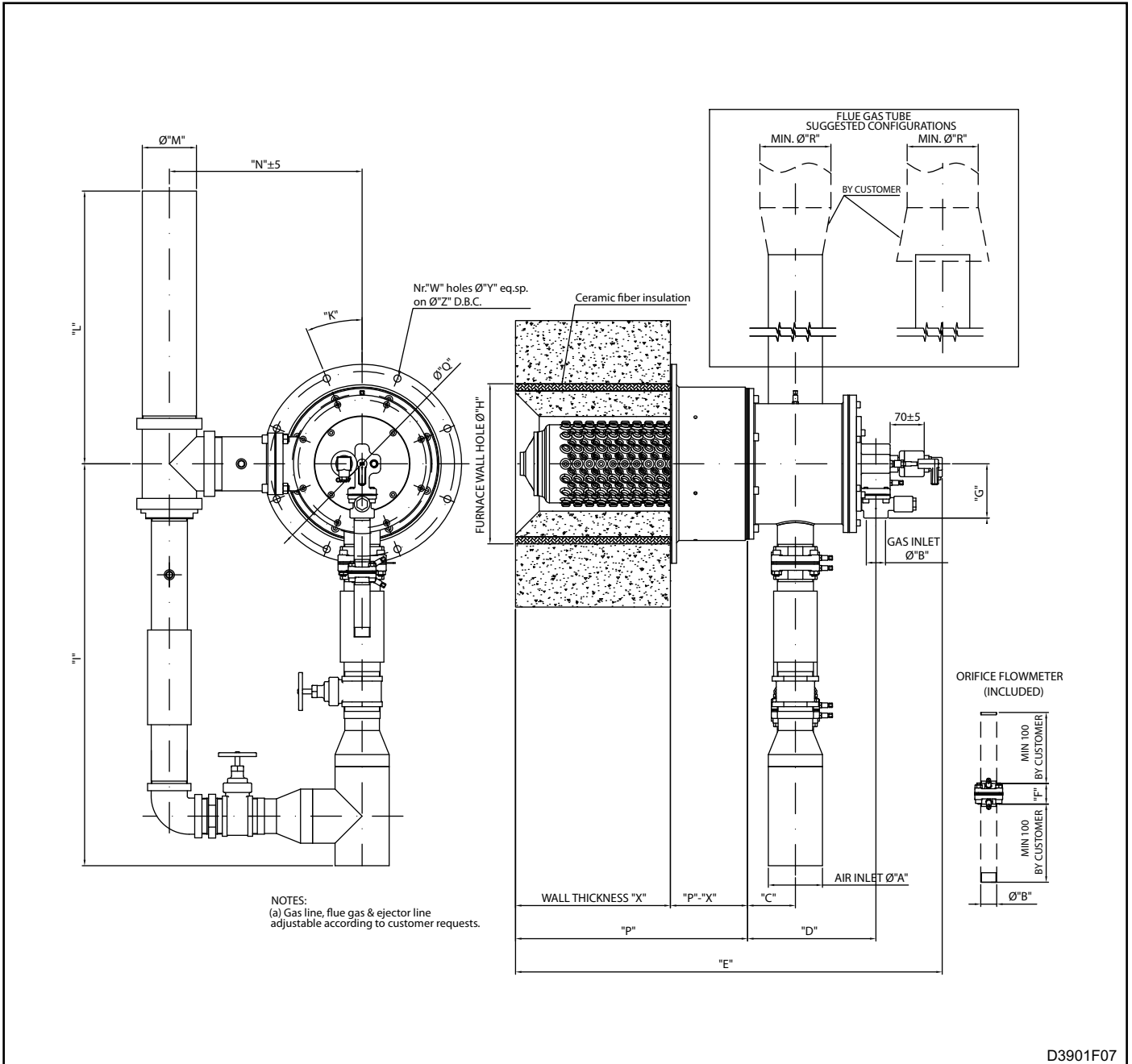

Burner Model	A	B	C mm	D mm	E mm	F mm	G mm	H mm	K mm	I mm	L mm	M mm	N mm	W mm	Y mm	Z mm	P mm	Q mm	R (*)	Mass Kg (**)
REKO-1-SIK	Rp 1.1/2"	Rp 1/2"	71	196	968	46	115	235	45°	465	442	Ø 2"	220	4	13	250	490	280	3"	55
REKO-2-SIK	Rp 2.1/2"	Rp 1/2"	91	225	850	46	115	270	45°	580	474	Ø 2.1/2"	260	4	13	295	490	320	3/1.2"	72
REKO-3-SIK	Rp 3"	Rp 3/4"	91	252	878	46	115	295	22.5°	650	478	Ø 3"	285	8	13	330	490	365	4"	100
REKO-4-SIK	DN100	Rp 1"	102	275	900	46	115	340	22.5°	848	580	Ø 4"	400	8	15	390	490	420	6"	118
REKO-5-SIK	DN100	Rp 1"	135	324	1020	46	115	440	22.5°	870	581	Ø 4"	442	8	15	470	560	500	7"	184
REKO-6-SIK	DN150	Rp 1.1/2"	140	350	1100	66	187	505	225	1042	620	Ø 6"	440	8	15	550	600	600	Ø 250"	305

Important note: "X" wall thickness is the responsibility of the Client.  
 (\*) Approximate diameter (depends on the exhaust pipe conformation).  
 (\*\*) Burner mass including air lines, ejector and furnace wall spacer.



**ORDERING INITIALS - COMPLETE BURNER**



Model		01
REKO-1-SIK	1	
REKO-2-SIK	2	
REKO-3-SIK	3	
... (ref. capacity table)	.....	

Version		04
Right	R	
Left	L	

Gas adjuster		02
With gas adjuster	GA*	
Without gas adjuster	F	

Wall thickness mm		05
Indicate length in mm (see size diagrams)	....	

Fuel		03
Natural gas	CH4	
LPG	GPL	
Poor gas (¹)	GP	

Flanging type		06
As ESA drawing	E*	
As customer drawing	C	

The initials marked with an asterisk (\*) identify the standards.

Notes:

¹ Particular performance according to gas characteristics

To check the components that are not supplied with the burner, consult the burner flow scheme on page 8.