

## Burners

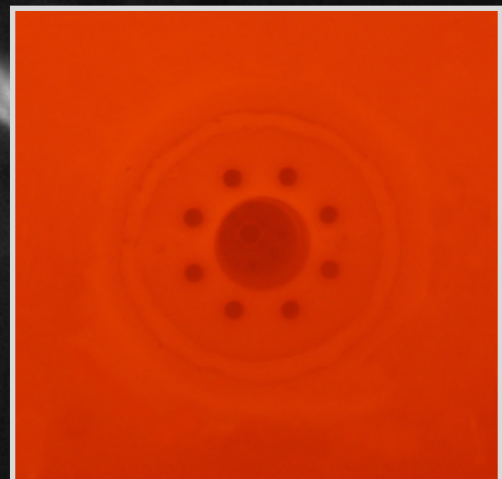

## LOW NO<sub>x</sub> lateral burners

ENM-NxT (E3400 rev. 03 - 04/07/2016)

## GENERAL WARNINGS:



- All installation, maintenance, ignition and setting must be performed by qualified staff, respecting the norms present at the time and place of the installation.
- To avoid damage to people and things, it is essential to observe all the points indicated in this handbook. The reported indications do not exonerate the Client/User from observing general or specific laws concerning accidents and environmental safeguarding.
- The operator must wear proper DPI clothing (shoes, helmets...) and respect the general safety, prevention and precaution norms.
- To avoid the risks of burns or high voltage electrocution, the operator must avoid all contact with the burner and its control devices during the ignition phase and while it is running at high temperatures.
- All ordinary and extraordinary maintenance must be performed when the system is stopped.
- To assure correct and safe use of the combustion plant, it is of extreme importance that the contents of this document be brought to the attention of and be meticulously observed by all personnel in charge of controlling and working the devices.
- The functioning of a combustion plant can be dangerous and cause injuries to persons or damage to equipment. Every burner must be provided with certified combustion safety and supervision devices.
- The burner must be installed correctly to prevent any type of accidental/undesired heat transmission from the flame to the operator or the equipment.

- The performances indicated in this technical document regarding the range of products are a result of experimental tests carried out at ESA-PYRONICS. The tests have been performed using ignition systems, flame detectors and supervisors developed by ESA-PYRONICS. The respect of the above mentioned functioning conditions cannot be guaranteed if equipment, which is not present in the ESA-PYRONICS catalogue, is used.

## DISPOSAL:



To dispose of the product, abide by the local legislations regarding it.

## GENERAL NOTES:



- In accordance to the internal policy of constant quality improvement, ESA-PYRONICS reserves the right to modify the technical characteristics of the present document at any time and without warning.
- It is possible to download technical sheets which have been updated to the latest revision from the [www.esapyronics.com](http://www.esapyronics.com) website.
- The ENM-NxT products have been designed, manufactured and tested according to the most correct construction practices and following the applicable requirements described in **UNI EN 746-2-2010** "Industrial heating process equipment - Part 2: Safety requirements for combustion and for the handling and processing of fuels". We emphasize that the burners described in this data sheet **are provided as independent units and are excluded from the scope of the Machine Directive 2006/42/EC** not having any mobile items that are not exclusively manual.
- Certified in conformity with the **UNI EN ISO 9001** Norm by DNV GL.



- For ESA-PYRONICS, the NxT symbol has the following two meanings which are connected to each other: **NEXT GENERATION**, or new generation burners that maintain functionality, reliability and performance. **NOx TECHNOLOGY** energy saving and low polluting emissions.

## CERTIFICATIONS:



The products conform to the requests for the Euroasia market (Russia, Belarus and Kazakhstan).

## CONTACTS / SERVICE:



### Headquarters:

Esa S.p.A.  
Via Enrico Fermi 40  
24035 Curno (BG) - Italy  
Tel +39.035.6227411  
Fax +39.035.6227499  
[esa@esacombustion.it](mailto:esa@esacombustion.it)

### International Sales:

Pyronics International s.a.  
Zoning Industriel, 4ème rue  
B-6040 Jumet - Belgium  
Tel +32.71.256970  
Fax +32.71.256979  
[marketing@pyronics.be](mailto:marketing@pyronics.be)

[www.esapyronics.com](http://www.esapyronics.com)

The ENM-NxT series identifies a family of lateral long flame burners that are used on various types of furnaces. According to their size and conditions of use, the ENM-NxT burners guarantee a substantial reduction in polluting emissions (CO & NOx) and lower consumption than traditional burners thanks to the design that has been optimized for the use of pre-heated air upto 600°C.

## APPLICATIONS

- Walking beam furnaces.
- Walking earth furnaces.
- Frit melting furnaces.
- Pusher type furnaces.
- Aluminium smelting furnaces.
- Thermal treatment furnaces
- Forge furnaces.
- Extension furnaces.
- Tile furnaces.



## CHARACTERISTICS

### GENERAL:

- Capacity: from 400 to 4400 kW
- Pre-heated air up to: 550°C
- Air pressure to burner: 50 mbar
- Gas pressure to burner: 50 mbar
- Double combustion mode:
  - **FLAME** with UV detection
  - **FLAMELESS** for ULTRA LOW NOx emissions
- Extremely low NOx e CO content
- Large flow ratio (average of 6 : 1)
- Maximum working temperature: 1600°C

### MATERIAL COMPOSITIONS:

- Burner body: carbon steel
- Gas collector: cast iron G25
- Air diffuser: refractory cement (T.max=1750°C)
- Gas tube: AISI304/AISI310S
- Body insulation: ceramic fibre
- Surface treatment: galvanization, steel pickling, high temperature painting.



### CAPACITY PARAMETERS AND FLAME LENGTH

The ENM-NxT burner ignition takes place through PBC-FR/X series pilot burners. The detection instead, is done via an UV-2 scanner (not supplied).

The adoption of flame control systems is highly recommended for all operating plants that have temperatures lower than 750°C (UNI EN746-2 regulations).

Model	Capacity kW	Flame length mm	Ignition	Detection
ENM-5-NxT	400	1700	42PBC-FR/X	UV-2
ENM-6-NxT	500	1800	42PBC-FR/X	UV-2
ENM-7-NxT	700	2200	42PBC-FR/X	UV-2
ENM-8-NxT	1000	3000	42PBC-FR/X	UV-2
ENM-9-NxT	1500	4000	64PBC-FR/X	UV-2
ENM-10-NxT	2000	4800	64PBC-FR/X	UV-2
ENM-11-NxT	2800	5800	86PBC-FR/X	UV-2
ENM-12-NxT	3600	6500	86PBC-FR/X	UV-2
ENM-13-NxT	4400	7500	86PBC-FR/X	UV-2

### DESCRIPTION

The ENM-NxT burners are LOW NOx burners and the most recent technical improvements have been applied so as to guarantee low NOx and CO emissions, remaining, however, functional even at low chamber temperatures, during their ignition when the plant is cold.

The burners are solid and robust, with limited dimensions and weight (the main insulation element is in ceramic fibre), with separate air and gas inlets, nozzle mixing (where flame backfire is impossible).

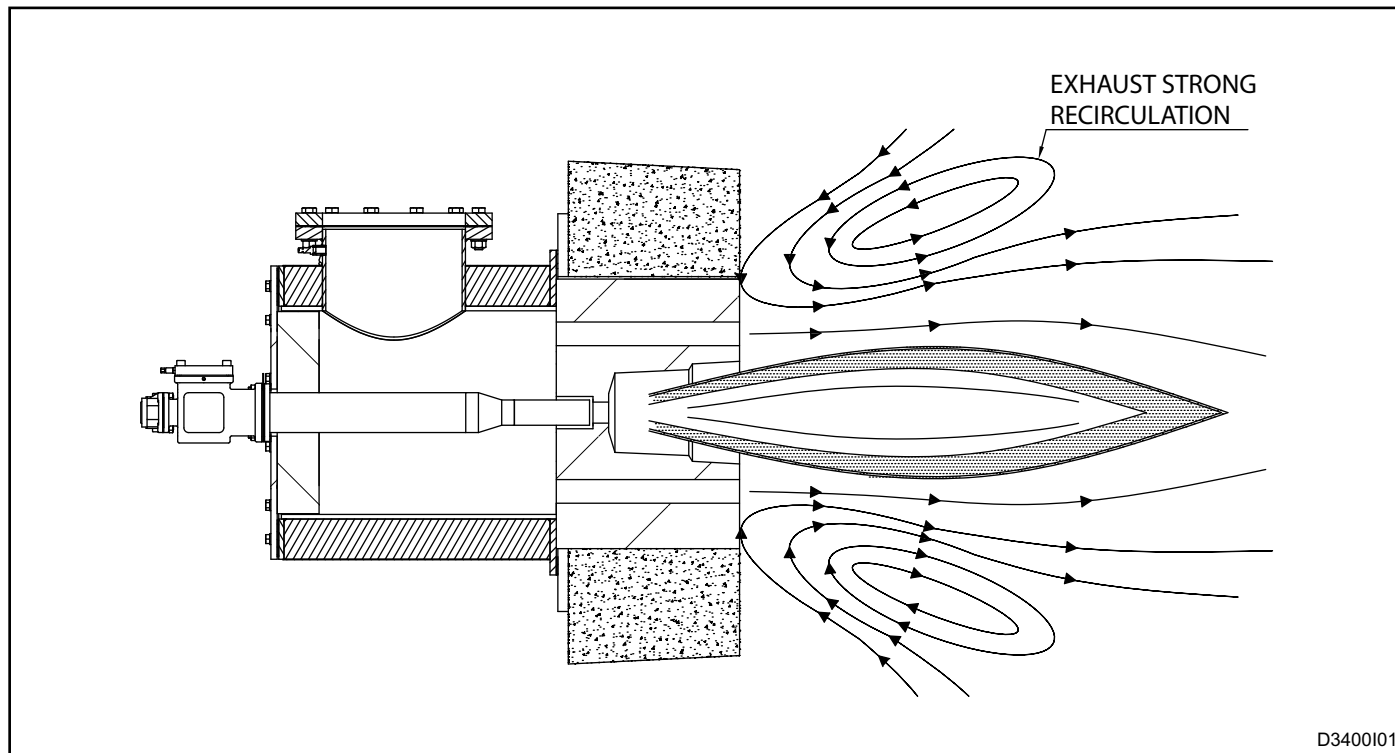

Multistage technology, together with the high combustive gas recirculation, guarantees low NOx and CO emissions, even with pre-heating temperature values of upto 600°C.

When it is necessary, the FLAMELESS version satisfies the strictest standards, in terms of emissions, maintaining however, the same air and gas feeding pressures as the standard version.



## BURNER PERFORMANCE

The capacities, flame lengths and velocities, refer to a burner fed by natural gas (8600 Kcal/Nm<sup>3</sup>), placed in a combustion chamber with zero pressure above sea level and functional with 10% of excess air.

- MIN/MAX functioning (ON/OFF)
- Chamber temperature 1200°C
- Pre-heated air temperature at 500°C

### MAXIMUM CAPACITY

Parameter			Burner model								
			ENM-5	ENM-6	ENM-7	ENM-8	ENM-9	ENM-10	ENM-11	ENM-12	ENM-13
<b>Max. capacity</b>	<b>Burner capacity (2% O<sub>2</sub>)</b>	<b>[kW]</b>	400	500	700	1000	1500	2000	2800	3600	4400
	Comburent air flow	[Nm <sup>3</sup> /h]	440	550	770	1100	1650	2200	3080	3960	4840
	Gas flow	[Nm <sup>3</sup> /h]	40	50	70	100	150	200	280	360	440
	Burner inlet air pressure	[mbar]	50								
	Burner inlet gas pressure	[mbar]	50								

### MINIMUM CAPACITY

Parameter			Burner model								
			ENM-5	ENM-6	ENM-7	ENM-8	ENM-9	ENM-10	ENM-11	ENM-12	ENM-13
<b>Min. capacity</b>	<b>Burner capacity (2% O<sub>2</sub>)</b>	<b>[kW]</b>	65	85	120	170	250	350	470	600	730
	Comburent air flow	[Nm <sup>3</sup> /h]	72	94	132	187	275	385	517	660	800
	Gas flow	[Nm <sup>3</sup> /h]	6.5	8.5	12	17	25	35	47	60	73
	Burner inlet air pressure	[mbar]	1.5								
	Burner inlet gas pressure	[mbar]	1.5								

**BURNER CAPACITY ACCORDING TO PRE-HEATED AIR TEMPERATURE**

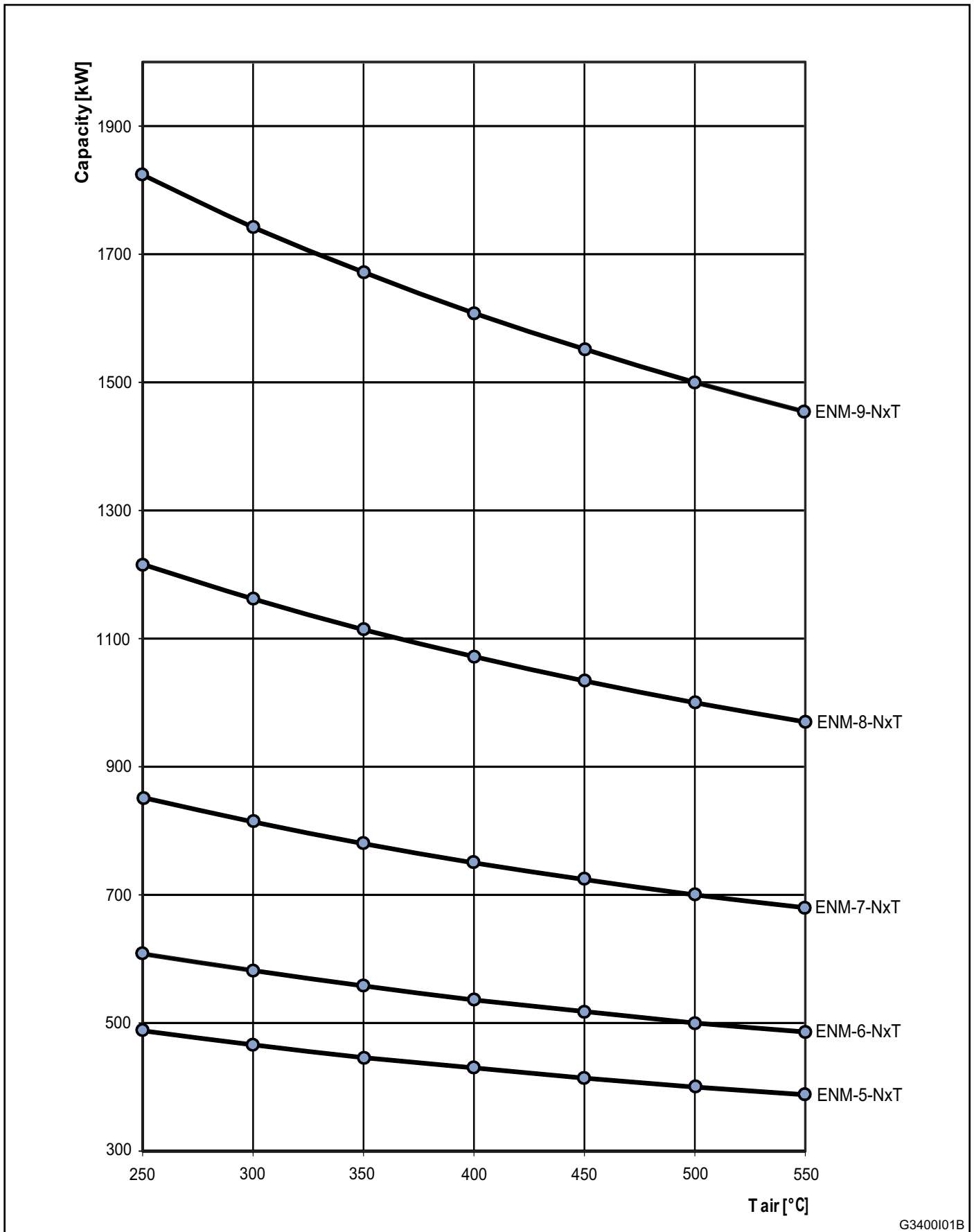

G3400I01B

**BURNER CAPACITY ACCORDING TO PRE-HEATED AIR TEMPERATURE**

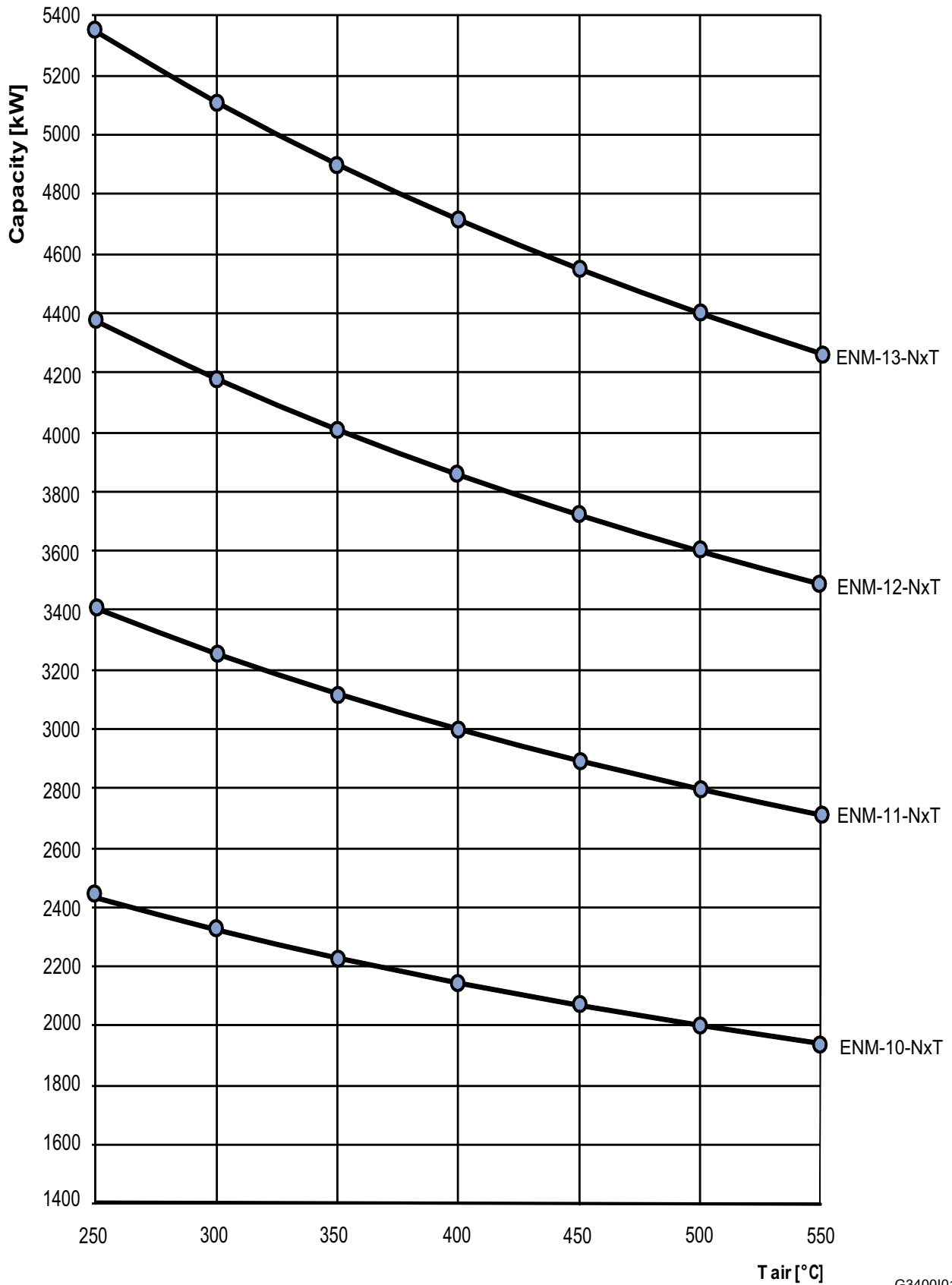

G3400101

## NO<sub>x</sub> EMISSIONS CHART

### STANDARD COMBUSTION (FLAME)

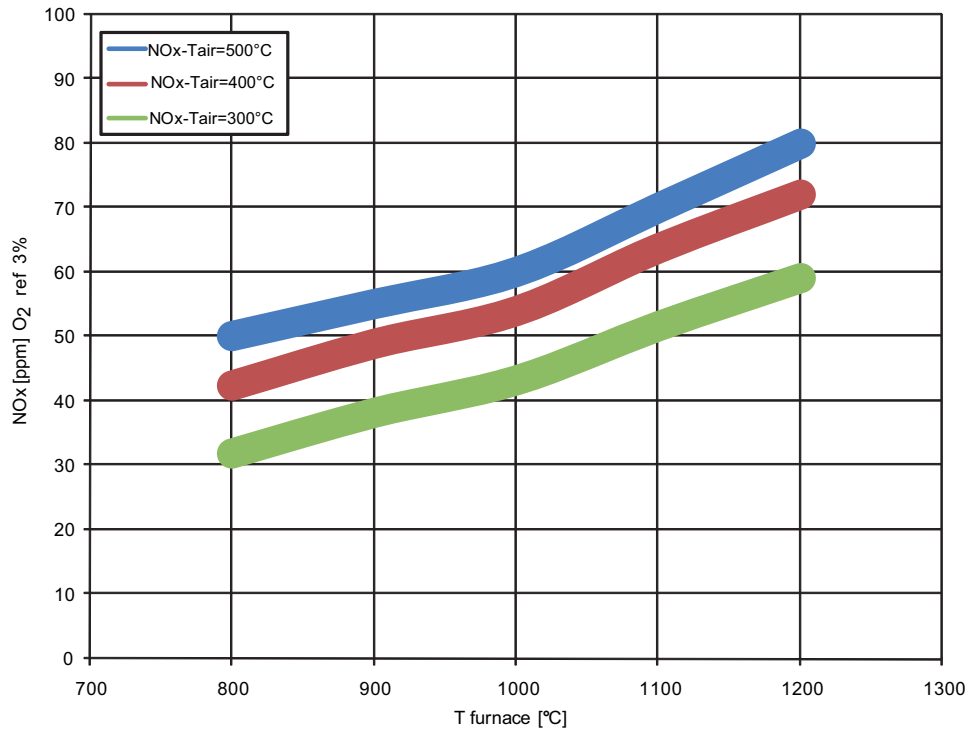

G3400I02

### COMBUSTION WITHOUT FLAME (FLAMELESS)

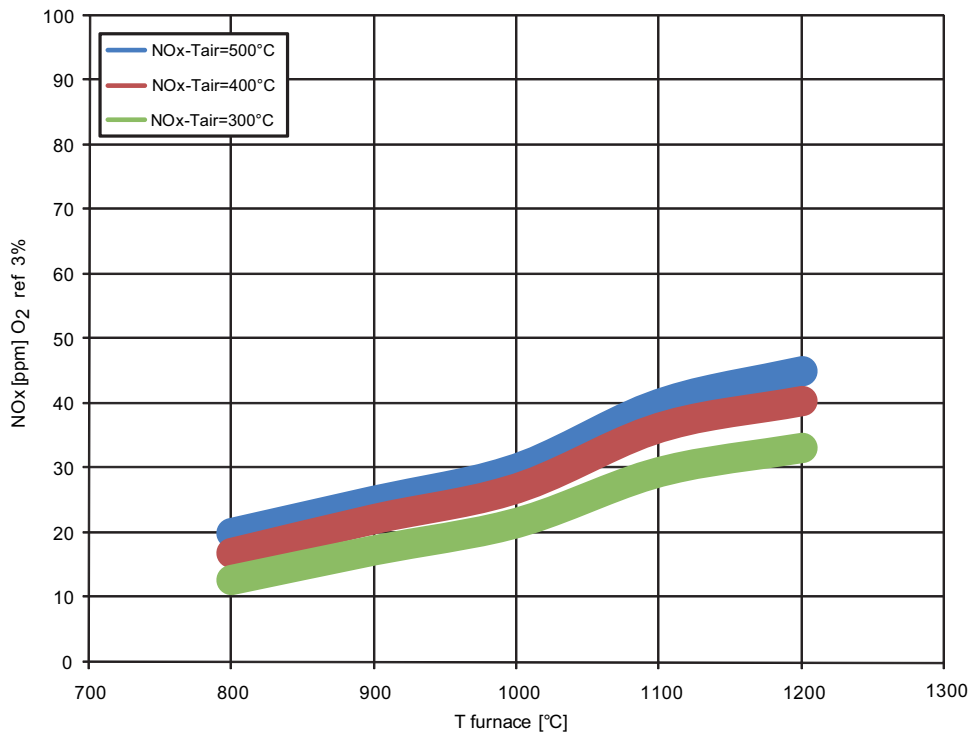

G3400I03

Burner at 100% capacity with 10% excess air

The emission value is subject to variations which depends on different factors such as:

- The furnace working temperature.
- heated air temperature.
- Excess air
- Chemical composition of the combustive agent.

The value guaranteed will thus be determined, case by case, according to the conditions indicated by the customer.



**CAPACITY FLOW CHART**

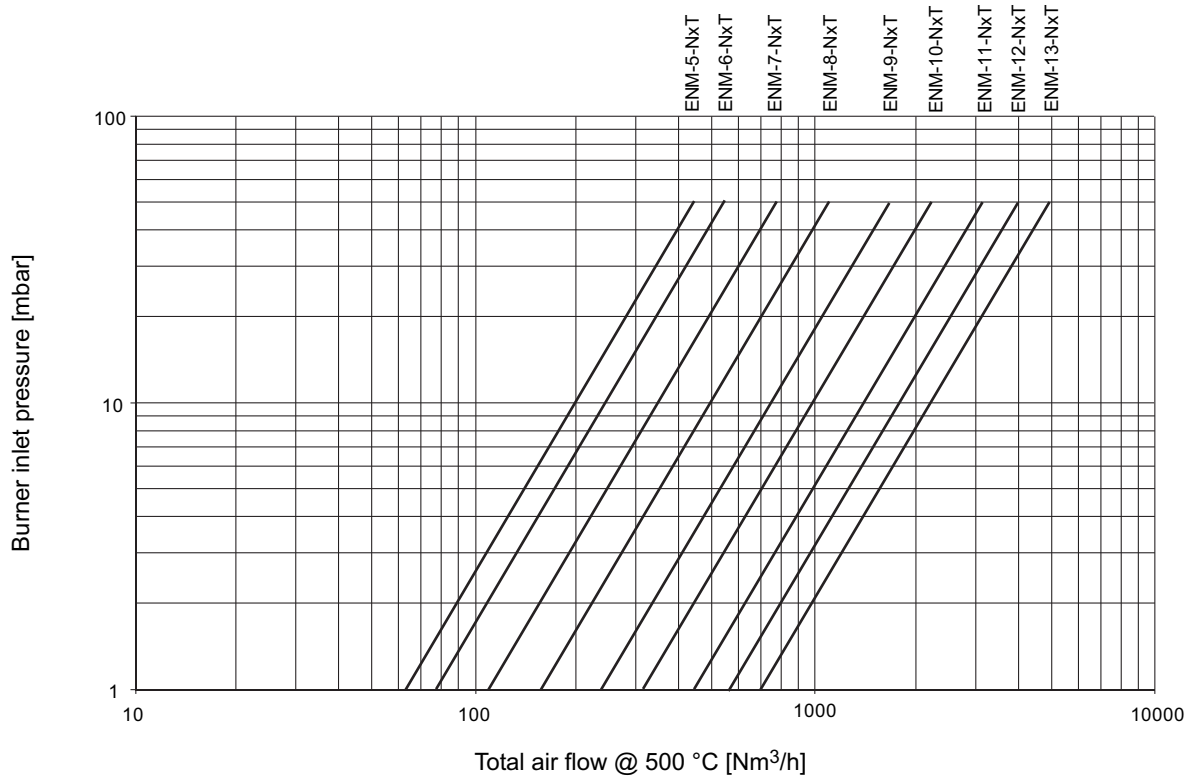

G3400I04

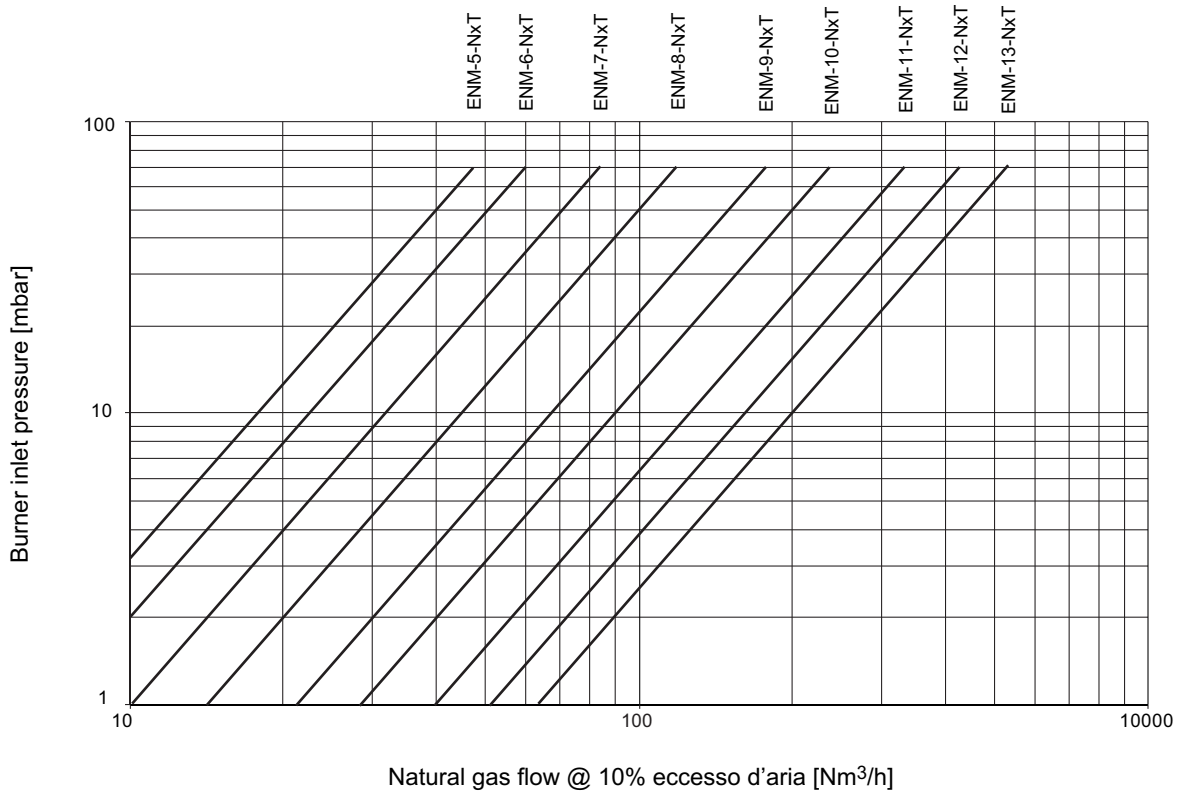

G3400I05

**FLOW SCHEME - ZONE REGULATION**

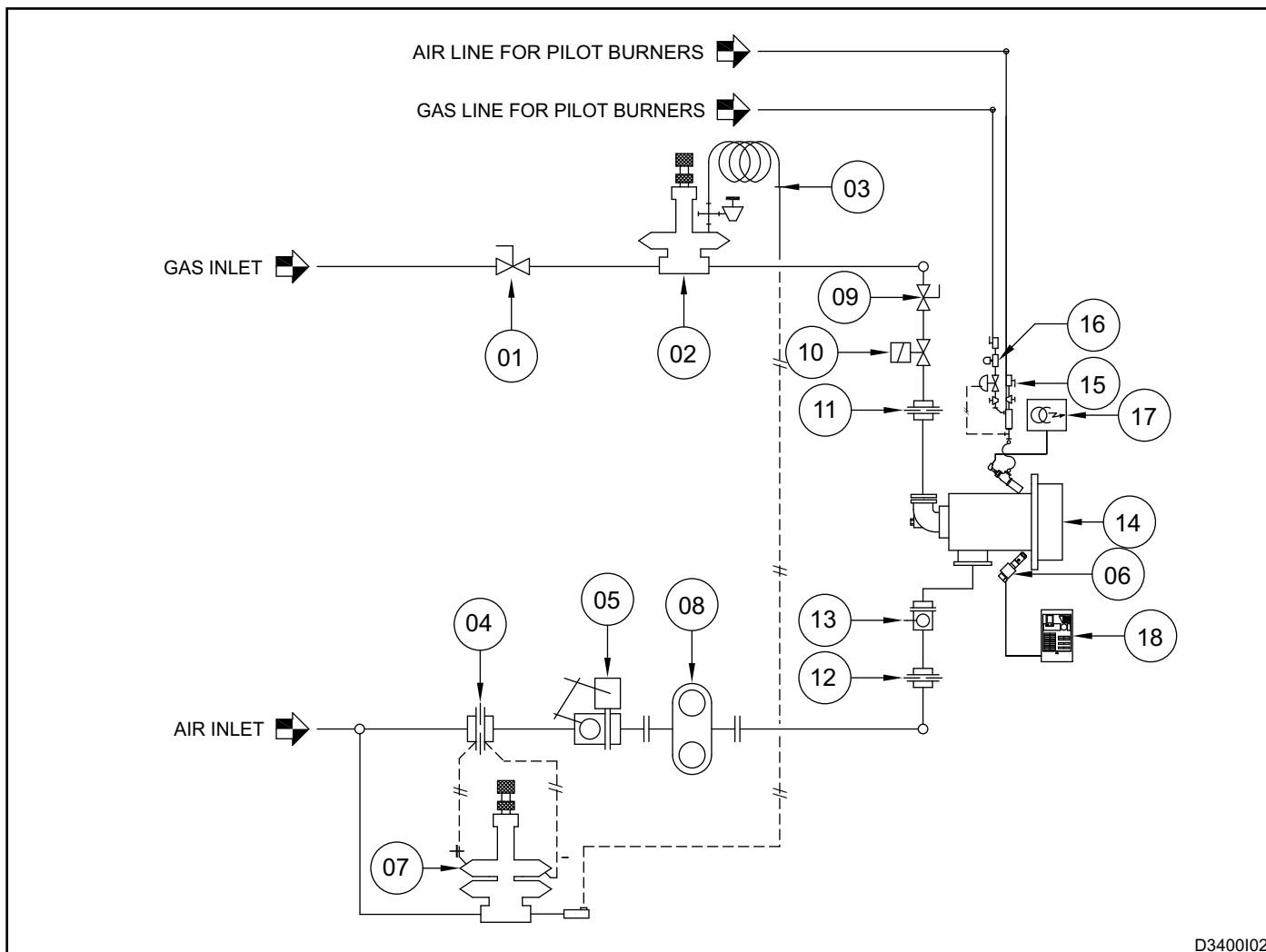

D3400102

Pos.	Description	Included	Not Included
1	Main gas interception ball valve		X
2	Zerogovernor		X
3	Impulse line		X
4	Calibrated flange with $\Delta P$ air measurement		X
5	Air regulation butterfly valve		X
6	Flame detection uv-scanner		X
7	Ratio regulator		X
8	Heat exchanger		X
9	Shut-off ball valve for the gas interception to each burner		X
10	Main burner solenoid gas safety valve		X
11	Single burner calibrated flange with $\Delta P$ gas measurement		X
12	Single burner calibrated flange with $\Delta P$ air measurement		X
13	Manual butterfly air regulation valve		X
14	Main burner	X	
15	Pilot burner		X
16	Pilot burner solenoid gas safety valve		X
17	Ignition transformer		X
18	Flame control device		X

**FLOW SCHEME - REGULATION IN ELECTRONIC RATIO**

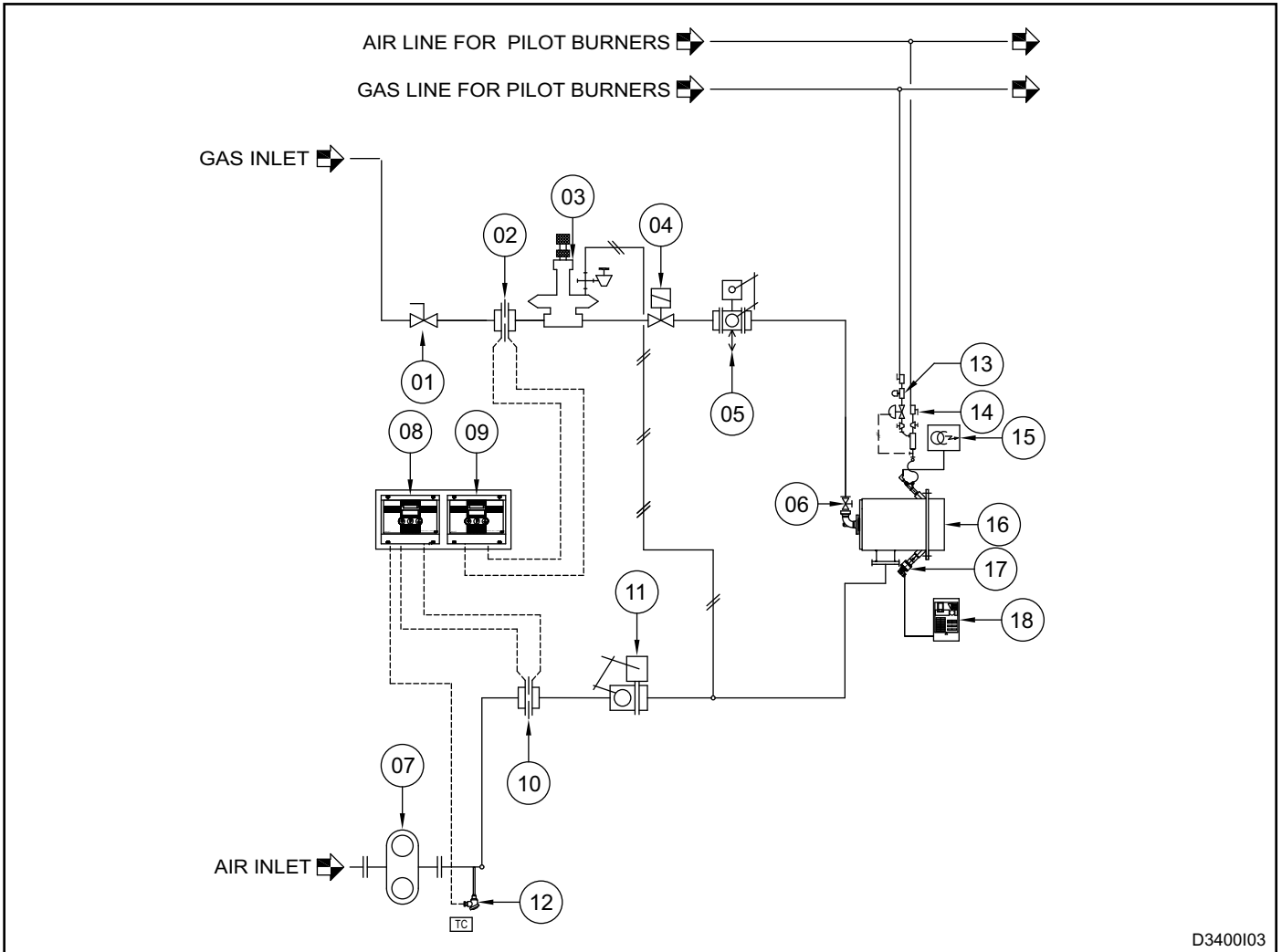

Pos.	Description	Included	Not Included
1	Gas interception ball valve		X
2	Calibrated flange with $\Delta P$ air measurement		X
3	Zerogovernor		X
4	Solenoid gas safety valve		X
5	Modulant gas valve		X
6	Gas passage limiting device		X
7	Heat exchanger		X
8	Air pressure transmitter		X
9	Gas pressure transmitter		X
10	Calibrated $\Delta P$ air flange		X
11	Modulant air valve		X
12	Compensation thermocouple		X
13	Pilot burner solenoid valve		X
14	Pilot burner		X
15	Ignition transformer		X
16	Main burner	X	
17	Flame detection uv-scanner		X
18	Flame control device		X

## WARNINGS

- The ENM-NxT series burners are to be used in fixed installations. If mobile installations should be necessary (bell furnaces, etc ...), take into consideration that possible damages could be caused due to the movement of the actual furnace.
- Burner ignition must always be carried out at minimum power, to then modulate towards the maximum, thus facilitating ignitions and reducing outlet overpressures.
- The passing from the minimum to the maximum power, and vice-versa, must be gradual and not immediate.
- For all applications at low temperatures (upto 750°C), the burner ignition as well as the combustive gas solenoid valve command must be carried out using a certified burner control device.
- The use of flexible joints is always necessary in the presence of pre-heated air.
- To avoid possible damage to the burners, make sure that the blower does not blow air which is fouled by combustion products, oils solvents or other. To avoid these phenomena from taking place, preferably install the blower or the suction duct outside the establishment and far from exhaust pipes.
- Check the correct connection of the feeding lines after installation. Before switching the burner on, check that the comburent air pressure and combustive gas pressure values are correct.
- The burner can only function within the indicated power range. Functioning with excessive power could compromise burner performance and life span. In that case the ESA PYRONICS general warranty conditions will automatically expire and ESA PYRONICS will not be held responsible for any damage caused to persons or objects.
- In case there are problems with the other devices during the burner start-up phase, for the connection of high tension cable to the ignition electrode, use the connector with an antidisturbance filter.
- Avoid burner ignition close to each other so as not to heat the ignition command system devices (solenoid valves and transformers). Prewash time lapse + first safety time lapse + min. of 5 sec. = time lapse between one ignition and another. (however, do not attempt more than 2 ignitions during a 30sec. time lapse).
- Make sure the power supply is TURNED OFF when intervening on the burner and its devices. In case of burner malfunctioning, follow the indications in the 'Maintenance' chapter of the present manual or contact ESA-PYRONICS assistance.
- Any modification or repair done by third parties can compromise the application safety and automatically cause the general warranty conditions to expire.

## INSTALLATION

The burners of the ENM-NxT series are generally side-wall burners. Roof installation is not advised and in case it is necessary, please specify during the order phase.

The light made for the burner positioning must leave space around the actual burner which is then to be filled with ceramic fibre cushion (vd. pag. 16).

The use of flexible pipes in AISI is compulsory for the connection of the air and gas lines to the burner. The air and gas inlets can be rotated to 90° and have flanges (UNI or ESA-PYRONICS) to be welded.

For installation, carefully carry out the following instructions:

- 1** - insert the burner body gasket (**pos.02**) on the wall of the furnace (**pos.01**).
- 2** - lift the burner up (**pos.03**) and fix it to the stud bolts (**pos.04**), checking that the gasket (**pos.02**) has not moved and is not deformed.
- 3** - tighten the anchor bolts.
- 4** - connect the air and gas lines to the burner using the flanges to be welded.

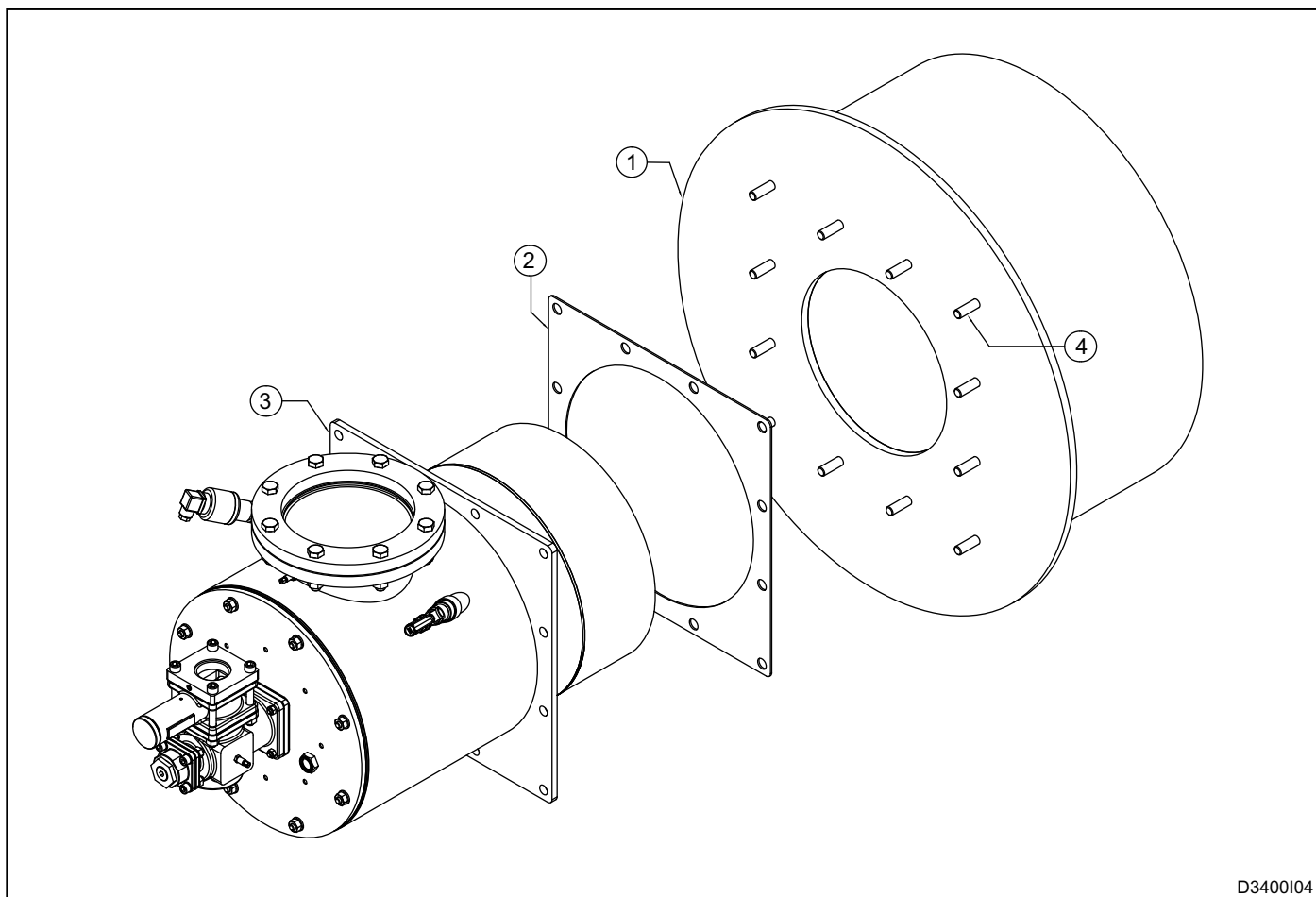

D3400I04

**INSTALLATION CARD ON FURNACE WALL**

WALL THICKNESS > DIFFUSER LENGTH

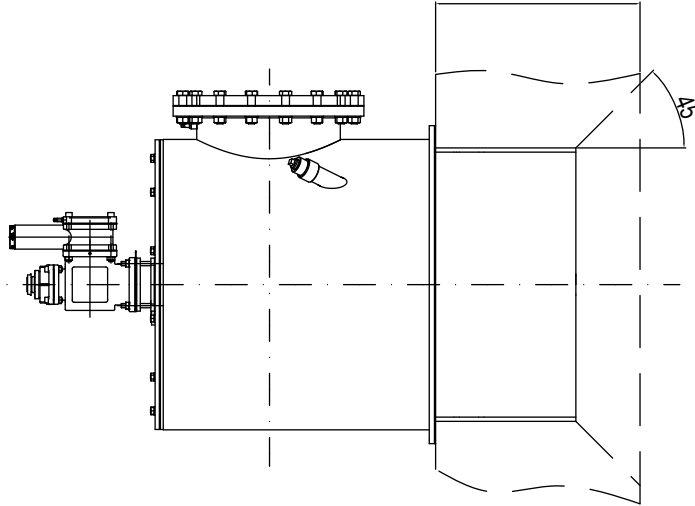

WALL THICKNESS = DIFFUSER LENGTH

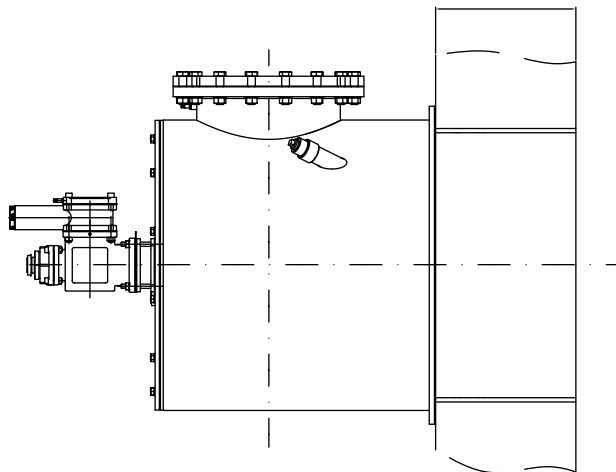

WALL THICKNESS < DIFFUSER LENGTH

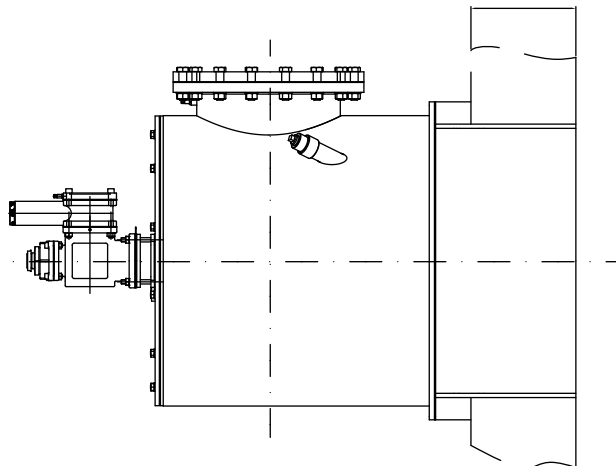

D3400105



## START-UP - SETTING

The procedures indicated in the following chapter must be carried out by expert technicians. The non-observance of the instructions given can provoke dangerous conditions.

- 1** - Check that the combustion air pressure exiting the blower and the combustive fuel pressure are both within the allowed range.
- 2** - Adjust the working pressure and the safety device pressure of the combustion plant, whether there is one per burner or one for the whole plant i.e. gas pressure reduction gear, block valve, relief valve, pressure switches etc. Simulate the intervention of all the safety devices including the intervention of the safety over temperature, checking that the fuel safety block devices react properly.
- 3** - Place the air regulation valve in the maximum opening position and adjust the burner inlet pressure referring to the values indicated in the 'Burner Performances' chapter.
- 4** - Place the air regulation valve in the minimum opening position and adjust its opening to obtain (in burner inlet and ejector) the relative minimum power pressure.
- 5** - Activate the burner control device and attempt the pilot burner (\*) ignition until it switches on. While attempting to ignite the burner, act on the gas adjustment valve and, starting from the totally closed position, open it gradually until the main burner ignites.
- 6** - Fully open the air regulation valve and adjust, via the gas adjustment valve, the maximum fuel capacity, checking the differential pressure created on the calibrated gas flange.
- 7** - Double check that, at minimum and maximum power, the burner inlet pressures correspond to the values in the 'Burner Performances' chapter. These values may differ depending on whether the burner is on or off.
- 8** - If necessary, with both burners running at the same power, analyse the combustion products in the chamber (where possible).
- 9** - Repeatedly attempt ignition at minimum burner power, with maximum amplitude, to check the ignition reliability and flame stability during the adjustment.

(\*) For pilot burner ignition and setting, please refer to n. E3280 technical data sheet.

**GENERAL MAINTENANCE PLAN**

Operation	Type	Advised time	Notes
<b>Pilot burner high tension electrode connector</b>	O	annual	check the integrity of the outer plastic and oxidization of the internal connector and of the electrode terminal
<b>Pilot burner ignition electrode</b>	O	annual	replace if the kantal terminal is worn
<b>Air diffuser integrity</b>	E	annual	at every maintenance check with furnace turned off, from the inside, make sure there are no cracks in the refractory material. Any cracks must be filled with special refractory material or liquid fibre.
<b>Cleaning of uv-scanner watch glass</b>	O	every semester	reduce to quaterly check in dusty environments
<b>Uv-scanner replacement</b>	O	10.000 h. of functioning	in any case, every two years
<b>Gas side gasket replacement (*)</b>	O	every two years	see note
<b>Burner settings</b>	O	annual	repeat all the steps in the "START-UP AND SETTINGS" chapter
<b>Oil lance check</b>	O	annual	check that the compressed air and oil holes are not occluded

NOTES:

Key: O = ordinary / E = extraordinary

(\*) it is suggested that the gaskets on the gas side be replaced after every dismantling of the gas feeding line and that high temperature gaskets be used.

## ORDINARY MAINTENANCE

For correct dismantling and better maintenance of the ENM-NxT burners, meticulously follow the instructions below with the plant turned off.

### CLEANING OF UV-SCANNER WATCH GLASS

- 1 - Check that the burner control device is not connected.
- 2 - Disconnect power supply to the uv-scanner (**pos.01**) and the cooling line (where present **pos.07**).
- 3 - Unscrew the aluminium pipe fitting (**pos. 06**) at the base of the gas collector, removing the uv-scanner with its spacer.

4 - Unscrew the aluminium fitting from the insulation teflon connector (**pos. 03**) and remove the quartz watch glass (**pos. 05**).

5 - Clean the quartz watch glass with a damp cloth and proceed to reassemble everything making sure that both the glass as well as the gaskets are put back in the correct positions (**pos. 04**) between the aluminium teflon spacer, before tightening.

6 - Restore the cooling hoses and power connection.

7 - Check the correct flame detection of the uv-scanner.

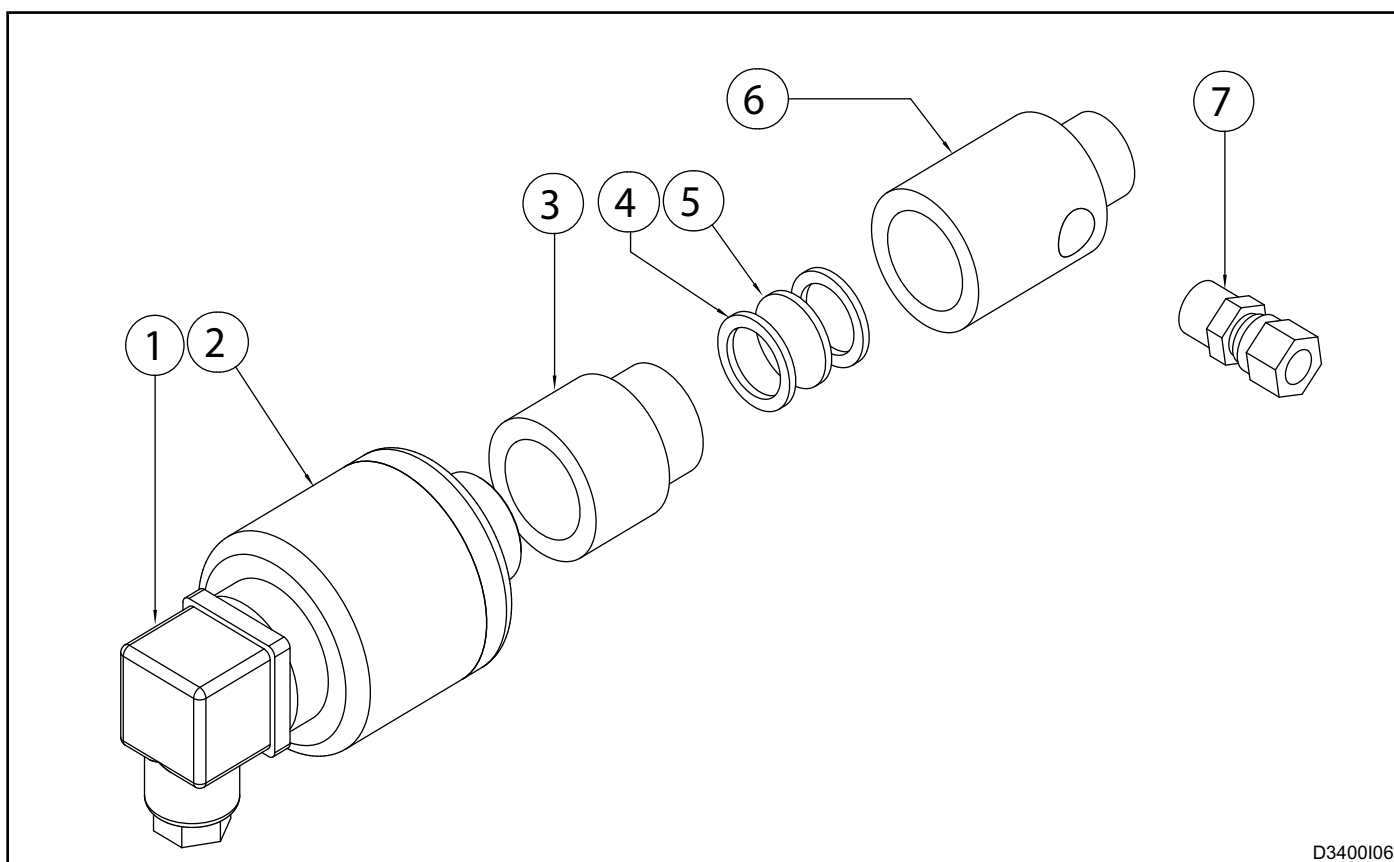

D3400106

## EXTRAORDINARY MAINTENANCE

For correct dismantling and better maintenance of the ENM-NxT burners, meticulously follow the instructions below with the plant turned off.

### BURNER IN LOCKOUT

In burner lockout conditions refer to the indications of the burner control device as well as the relative manual to identify the cause. After this, the main cases have been indicated below:

■ **Illegal flame detection:** lockout due to illegal flame signal detection during the phases that precede the ignition or following the switching off. The causes could be due to the detection system (broken sensor or presence of humidity), or else in the gas drawn by the safety solenoid valve which allows the burner to remain on.

■ **Ignition failure:** lockout due to missing flame formation during start-up. The causes could be due to the ignition system (missing spark, broken electrodes or electrodes not in correct position), in bad regulation of the flow fuel or combustive agents or in the detection system (broken sensor or interrupted cables). Specifically, in the first two cases the flame does not trigger off, whilst in the last case, the flame forms but the burner control device is unable to detect it.

■ **Flame signal loss:** lockout due to flame signal loss during the normal functioning of the burner. The causes may be found in the regulation of the fuel flow or combustive agents (rapid flow variations, regulation out of allowed range) or in the detection system (broken, dirty or badly positioned sensors).

### UV-SCANNER REPLACEMENT

- 1 - Check that the burner control device is not connected.
- 2 - Disconnect the electrical flow to the uv-scanner (**pos. 01**) and to the cooling line (where present).
- 3 - Unscrew the aluminium pipe fitting at the base of the gas collector (**pos. 02**), removing the uv-scanner with its spacer.
- 4 - Screw the new component back on, in the same position, after having checked the correct position of the watch glass insulation between the aluminium and teflon spacers.
- 5 - Restore the cooling pipes and the electrical connection.
- 6 - Check the correct uv-scanner flame detection.

### AIR DIFFUSER REPLACEMENT

- 1 - Disconnect all the air and gas lines to the burner.
- 2 - Dismantle the burner from the furnace wall and place it with the diffuser facing upwards, fixing it onto a special

support plate (concerning this, check the dimensions and weight in the "OVERALL DIMENSIONS" section).

3 - Unscrew the uv-scanner and pilot burner fixing connections (**pos.5**) and extract them from their position.

4 - After having removed any possible parts of ceramic fibre insulation from around the air diffuser, unscrew the security dowels (**pos.1**) and remove them from the burner body refractory element.

5 - Extract the damaged air diffuser (**pos.2**) and clean the area in which it is positioned making sure it is free from material that could obstruct the positioning of the new diffuser. Pay close attention to not damage the refractory inserts (**pos.4**), where present. If necessary, replace them with integral spare parts.

6 - Replace the gasket (**pos.3**) between the diffuser and the burner body, placing the new diffuser in the exact same position.

7 - Place the new air diffuser so that the holes of the security dowels correspond to the holes on the diffuser, respecting its proper keying compared to the burner body.

8 - Reposition the security dowels and check the actual blocking of the diffuser.

9 - Place the burner fixing connections back into the special slots (**pos.5**) and make sure that they do not interfere with the holes on the actual diffuser.

10 - Visually inspect the correct positioning of the flame and pilot burner uv-scan detector, both on the outside of the burner as well as on the part inside the air diffuser.

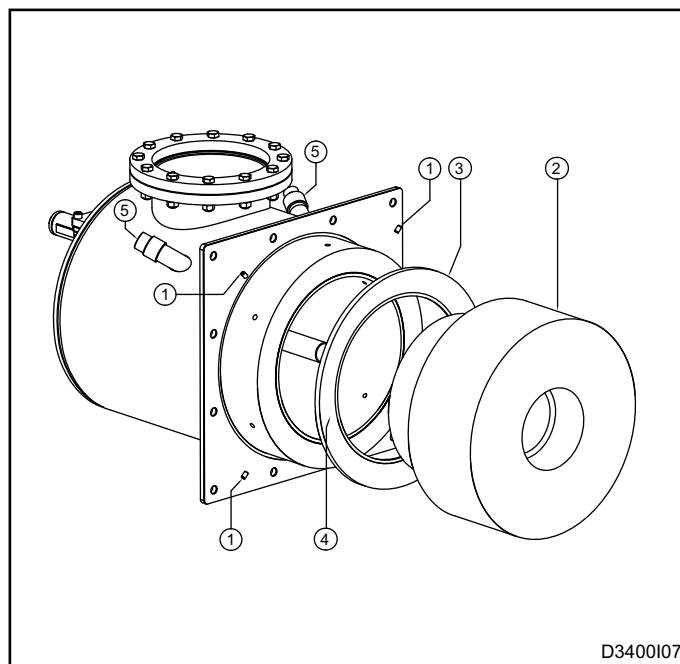

D3400I07

**OVERALL DIMENSIONS - ENM-NxT**

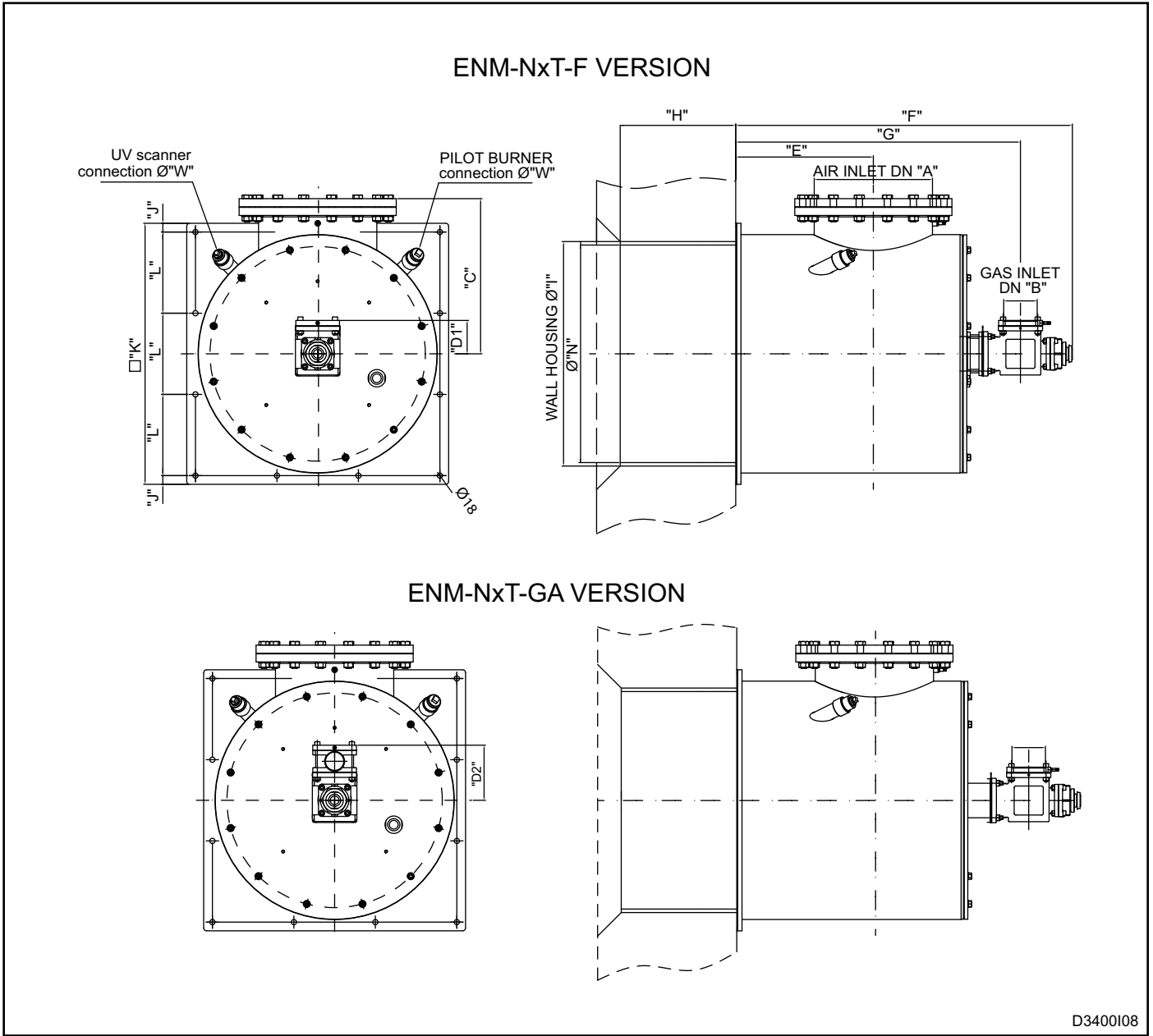

Burner Model	DN "A"	DN "B"	C [mm]	D1 [mm]	D2 [mm]	E [mm]	F [mm]	G [mm]	H [mm]	ø I [mm]	K [mm]	J [mm]	L [mm]	ø N [mm]	ø W [mm]	Mass [Kg]
ENM-5-NxT	100	40	291	70	110	302	661	548	163	290	400	20	360	273	Rp 3/4"	92
ENM-6-NxT	150	40	291	68	108	302	691	590	173	310	400	20	360	300	Rp 3/4"	98
ENM-7-NxT	150	40	307	71	110	387	743	675	263	384	450	15	140	364	Rp 3/4"	136
ENM-8-NxT	200	50	319	93	152	412	833	730	273	450	520	20	160	430	Rp 3/4"	191
ENM-9-NxT	250	65	381	93	156	442	886	802	348	544	630	30	190	524	Rp 1"	332
ENM-10-NxT	300	65	411	119	192	472	1037	908	368	600	680	25	210	580	Rp 1"	419
ENM-11-NxT	350	80	493	119	192	488	1068	939	367	720	810	30	250	700	Rp 1.1/4"	598
ENM-12-NxT	400	80	535	119	192	563	1194	1065	397	780	900	30	280	760	Rp 1.1/4"	783
ENM-13-NxT	400	100	575	119	192	613	1224	1105	417	885	980	25	310	865	Rp 1.1/4"	993

**ORDERING CODE - COMPLETE BURNER**



Model		01
ENM-7-NxT	7	
ENM-8-NxT	8	
ENM-9-NxT	9	
... (see capacity chart)	.....	

Gas adjuster		02
With gas adjuster	GA*	
Without gas adjuster	F	

Fuel		03
Methane	CH4 *	
LPG	GPL	
Poor gas (¹)	GP	

04 Ignition	
Pilot	P*
Without ignition	NI

05 Flame detection	
UV flame detection	UV*
Without flame detection	ND

06 Flame mode	
Standard burner	F*
Flameless burner	FL**

07 Flange type	
Acc. to ESA drawing	E*
Acc. to client drawing	C

The codes indicated by the asterisc (\*) identify the standard items.

(\*\*) GA (Gas Adjuster) inlet not possible.

Notes:

¹ Special manufacturing done according to the characteristics of the type of gas used