

KORRY® 389 5/8-inch switches and indicators with LED lighting



Table of Contents

This Chromalux® 389 technical guide addresses the switch development needs of a variety of users, from the novice to the highly technical, to help them determine the configuration and options required for a specific application.

Advantages of LED Illumination	2
Overview of the benefits provided by the LEDs and KORRY's patented circuitry integrated into the 389.	
General Design Features	4
Summary of the 389 product line's capabilities and versatility. The 389 line offers the reliability and flexibility required by the rapidly changing avionics and electronic industries.	
Product Configuration	11
Detailed mechanical drawings and specifications for lens configuration, operational characteristics, mounting, pin-out, magnetic latching, sealing, and other product options, to facilitate integration into a control panel or an electronic subsystem.	
Electrical	24
Electrical characteristics of specific configurations.	
Optical	30
Details of the 389's industry-leading optical characteristics.	
Environmental	34
Summary of the 389's qualification, including testing to MIL-STD-810 and commercial RTCA/DO-160 environments.	
Reliability	37
MTBF for various product elements based on KORRY's analysis and field data.	
Installation	38
Instructions for installing single-sleeve and double-sleeve units.	
Order Form	44
Glossary	46
A summary of basic switch product terminology to help during technical consultations with KORRY technical representatives.	

Advantages of LED Illumination

Current commercial and military equipment manufacturers have been exploring alternatives for high-reliability, low-maintenance switch designs that replace incandescent lamp technology with a more robust, longer-life light source. Advancements in Light Emitting Diodes (LEDs) and the development of sunlight-readable LED displays make this technology ideal for replacing existing incandescent sources. The variety of LEDs available today supports all commercial and military colors.

KORRY has worked extensively with LEDs over the past decade and has developed patented LED circuitry to provide plug-and-play incandescent-to-LED retrofits and programmable LED dimming capabilities compatible with night-vision compatibility requirements. KORRY's state-of-the-art LED solutions, included in the 389 product line, offer significant advantages.

Reduced Maintenance

Reduction of maintenance cost has been a major goal for new product development in the increasingly cost-competitive market. KORRY 389 LED switches offer life-of-the-aircraft performance. Replacing incandescent lamps in switches alone is a costly task, and research conducted has shown that the single most frequent cause of switch failure is damage during the relamping process.

Resistance to Shock and Vibration

The mechanical ruggedness and solid-state nature of LEDs result in excellent resistance to shock and vibration. In contrast, filament damage in incandescent lamps is not only common, but is generally expected during shock and vibration testing. In some applications, it is common to replace many of the lamps after each mission due to the severe shock and vibration. LEDs in these conditions have been shown to suffer no degradation in performance. KORRY LED products have successfully endured shock and vibration testing per MIL-STD-810C and MIL-STD-202F.

Reduced Touch Temperature and Power Consumption

Reduced touch temperature is another major advantage of an LED switch. Incandescent lamps produce substantially more heat than LEDs and have a relatively low luminous efficiency. LEDs however are very efficient at producing visible light and can provide a high luminous efficiency. LEDs require lower power consumption for a given level of illumination.

Improved Color Stability

LEDs can maintain distinct color separation in both Dim and Bright mode without the major color shifts seen in incandescent lamps as voltage is decreased. KORRY takes full advantage of these characteristics to provide 389 LED switches with more stable color output than incandescent products at varying illumination levels.

KORRY Patented LED Circuitry for Ease of Retrofit

LEDs are solid-state devices and require other components to drive them at the proper currents. Most systems are designed to use incandescent lamps, and to replace existing incandescent switches with LED switches requires as little impact to the systems as possible.

KORRY's 389 line offers patented LED driving circuitry, built directly into the unit, which allows a direct drop-in replacement of incandescent units. This circuitry also adjusts for the different dimming characteristics of LEDs and incandescent lamps and

makes LED units polarity insensitive. The result is that the lighting performance of KORRY 389 units matches or improves on existing incandescent products without requiring any modification of electronics.

In addition, KORRY has developed patented programmable dimming circuitry to address the very low luminance levels required for night-vision compatibility.

Reliable Operation in High-Temperature Environments

Temperature can have a significant impact on LED performance and life expectancy. Accordingly, KORRY conducts thermal analysis on all LED designs to assure proper derating of all electronic components, incorporates heat dissipation in the LED array, and moves heat-generating electronics away from the LEDs.

General Design Features

The KORRY Chromalux® 389 LED illuminated product has been engineered for high reliability for use in sophisticated electronic systems and for versatility in electrical interface requirements. KORRY has integrated the latest advances in surface-mounted electronics with the latest generation of high-brightness LEDs. As testimony to its innovative engineering, KORRY has been awarded patents for its electronic circuitry design used in the 389 product line. The 389 delivers uncompromising performance in system interface capabilities and in illumination characteristics such as brightness output and dimming control.

To support customers' needs, KORRY has designed the 389 to be mechanically interchangeable with most 5/8-inch switch designs. Contact KORRY engineering for further details.

Mechanical Construction

The basic mechanical construction of the Chromalux 389 LED consists of a combined cap and base assembly attached by a flex circuit. The 389 is configured as a four-pole momentary or alternate action push-button switch or as an indicator.

The cap assembly pulls out from the base assembly to allow access to the two mounting cam screws for installation or removal of the assembly. The cap assembly is keyed to the base assembly to prevent improper orientation during re-assembly.

The subminiature switch circuitry and LED illumination circuitry are isolated and separate circuits.

The basic switching mechanism is an integrated four-pole, double-throw switch module comprised of four independent subminiature switch elements. It is located in the base of the complete switch assembly. The four independent subminiature switches meet the requirements defined in MIL-PRF-8805/109.

Cap and Legends

The cap assembly contains legend indicia used for system functional indication and LEDs for color illumination and status indication.

When a larger switch button is required, the 389 can be configured with a mushroom cap or a larger rectangular cap. These configurations allow more legend surface along with a larger operator interface contact area.

The standard sealing for the 389 is drip proof. To meet splash proof requirements, an externally sealed cap is available that prevents moisture intrusion into the switch.

An array of board-mounted LEDs provides illumination for the legend displays. The reflector design optimizes the energy and location of these illumination sources. The LEDs have a 140° viewing angle, which when integrated into the reflector design, provide optimum uniformity and viewing angles. The character-to-character uniformity is less than, or equal to, a 2:1 ratio, and the displays are viewable to 70° in every direction from normal.

The legend nomenclature is embedded in a one-piece cast legend. This legend is insert-molded in a cap shell forming an integral assembly that prevents the ingress of contaminants. The one-piece legend is designed using proprietary software that provides exact chromaticity and transmission information automatically downloaded into the fabrication process.

KORRY legends are designed with a durable flat matte finish that diminishes specular reflections. A flat matte finish absorbs and scatters sunlight, where a smooth finish simply reflects sunlight back at the user.

The display circuitry is configured for redundancy in the event of an LED failure. The failure of one LED does not affect the operation of the remaining LEDs or result in a catastrophic failure of the display.

Reliability

The 389 electrical design goal is to derate all components to operate at 50 percent of the dissipated power. This design goal also improves thermal management of the overall optical characteristics by minimizing color shift and producing longer life.

LEDs in the 389 are isolated from other electrical components in the cap assembly. This insulates the LEDs from any heat generating components and provides increased LED reliability and life. The LED power conditioning, LED protection, and LED dimming circuitry are all located in the body of the assembly, providing for efficient heat transfer.

The 389 design also supports continuous illumination through the use of a single flex circuit between the cap assembly and base assembly. This flex circuit is strain-relieved at the service loop between the base assembly and cap assembly to permit free motion of the cap assembly. It is designed to prevent damage during installation and removal, and provides the perfect substrate for the illumination control and protection circuitry required in today's sophisticated systems.

Flex Circuit

The flex circuit contains electronic circuitry for appropriate power conditioning, LED protection, and LED dimming components. The LED protection circuitry enables the 389 to survive the stringent MIL-STD-461 and RTCA/DO-160 EMI and RFI environments. Circuitry has also been incorporated to address ESD, lightning strike, reverse voltage, voltage spike, and voltage surge conditions. LED life is drastically reduced without this protection.

KORRY has developed and packaged internal dimming circuitry, which allows customized LED brightness settings for Bright, Dim, and NVIS level.

KORRY's patented internal dimming circuitry also provides dimming curves that simulate incandescent dimming.

The 389 contains circuitry that allows the switch to operate like an incandescent bulb by being polarity insensitive. Power and ground can be applied to either side of the LED circuit and still operate.

Tactile Response

The 389 design accommodates two different tactile levels. The high-level tactile feedback assembly is generated from an industry standard snap-action-over-center mechanism. The lower level tactile feedback assembly uses a helical-spring, force-cup design that provides a lower level tactile response while depressing the cap. The cap assembly provides the system status through the illumination color and legend indicia.

Optional Magnetic Latching

The 389 can also be configured with an electromagnetic coil latching mechanism replacing the mechanical actuation mechanism. When energized, the coil will maintain the subminiature switch state after the cap assembly has been released. The coil configuration allows the switch to change state when power is lost or changed remotely by removing coil power.

Mounting options

The 389 features three different mounting options: single sleeve with connector module, double sleeve with connector module, and printed wiring board (PWB) connector. Both single and double-sleeve mountings incorporate a solderless connector module that uses wire crimp pins per MIL-C-39029/57-354 (22-26 gauge) or MIL-C-

39029/22-192 (20-24 gauge). Single-sleeve mounting requires access to the back of the mounting panel for both initial installation and replacement. Double-sleeve mounting requires access to the rear of the mounting during installation only. The double sleeve allows switch removal and replacement without access to the rear of the mounting panel and without affecting wiring or terminations. The PWB mounting allows the 389 to plug into a PWB header that is soldered into the circuit board.

KORRY Chromalux 389 Quick Switch

In order to provide customers with shorter lead times, KORRY has developed the 389 Quick Switch, which can be shipped to the customer within 10 days after the order has been received. The 389 Quick Switch is the same high-quality product available in the standard lead time but with limited configuration options. Reducing the configuration options allows long-lead parts to be stocked and quickly assembled into the final product.

The 389 Quick Switch is only available in the options shown below and detailed in the Product Configuration section of this brochure:

1. Wire lead crimp pin poke home electrical interface
2. 5-pin (M39029/22-192) and 6-pin (M39029/57-354) display terminations
3. Full and split cap assembly displays
4. Standard 28 VDC input with Bright and Dim luminance control as defined per variable voltage input dimming.

To help facilitate the order, KORRY has a dedicated Quick Switch applications engineering team available to support customers. You may submit your orders via email to Carrie Anderson at carrie.anderson@esterline.com or by fax to (425) 297-9870. For questions you may call (425) 297-9700 or toll-free (800) 257-8921 (US only).

Dimming

Below are the five most common methods and applications to control illumination level: The examples below demonstrate typical voltages. KORRY can accommodate a variety of voltage levels depending on the end use requirements.

1. Variable Voltage Input: This method is a simple voltage control system that controls the illumination by changing the voltage provided to the switch. The switch Bright and Dim modes are set by adjusting the internal switch circuitry to meet a specified luminance value at two different voltages. The Bright and Dim mode can be set to customer determined values. The luminance between the values will be linear. This circuit can be used to approximate an incandescent dimming curve. Typical voltage points for this method would be 28 VDC for Bright/14 VDC for Dim. This method is also effective for toggle dimming where a toggle switch is used to switch between Bright and Dim mode luminance values.

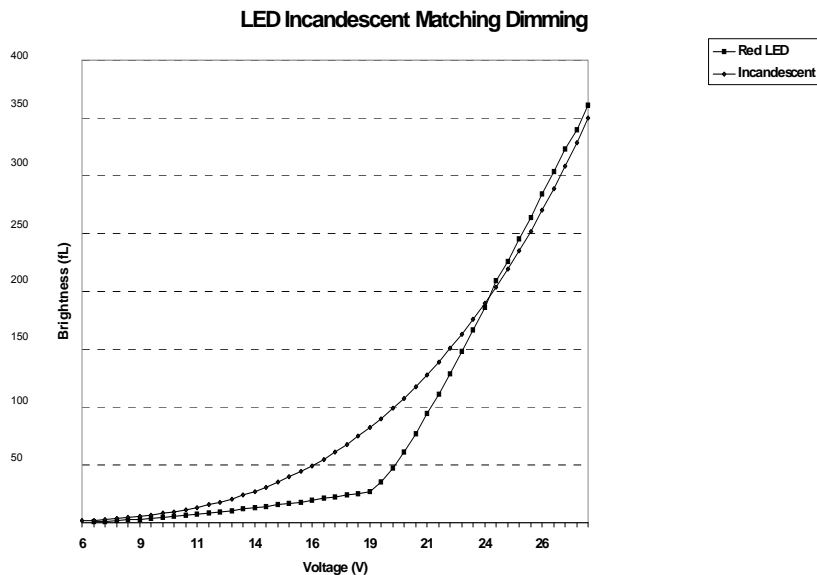
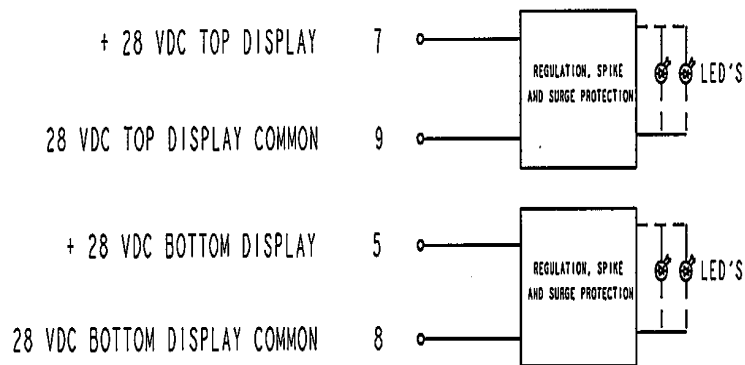

2. Logic Input: This method is a simple two-point or three-point illumination system. The input is a single 28 VDC power input to a pin on the switch and changes state between Bright and Dim mode by grounding an additional pin. The output is a discrete Bright and Dim mode at pre-selected luminance values. Three levels require an additional pin for a third dim level luminance.

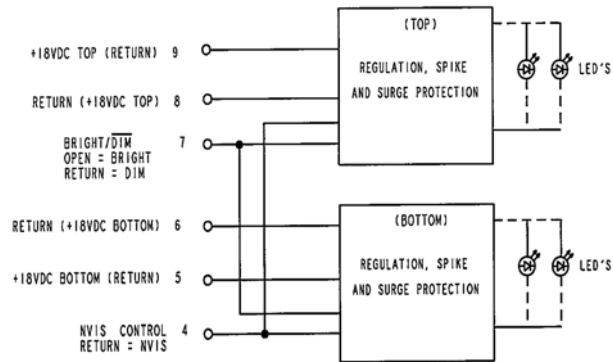

3. 3 Level Analog Control: This method achieves a steady illumination over a range of voltages, i.e. maintain Bright mode illumination over a voltage range of 28 to 20 VDC, a mid range from 20-14vdc and a low level luminance from 13 to 10 VDC.

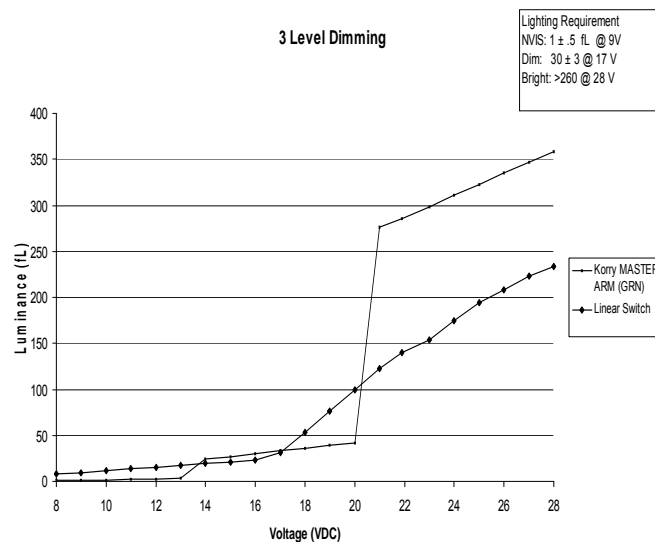
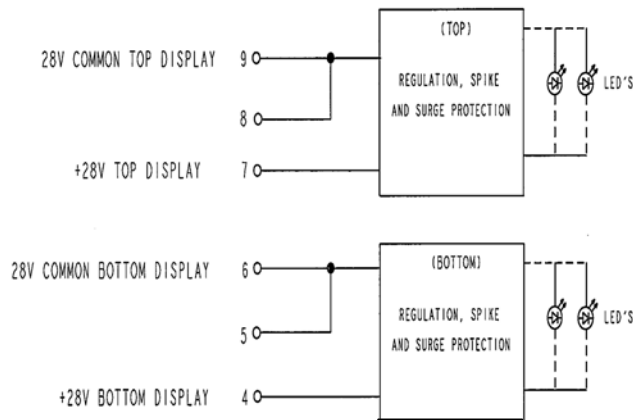

4. Adjustable Duty Cycle Pulse Width Modulation (PWM): This method is used to illuminate the LED using a PWM controller that has a continuously adjustable duty cycle control.

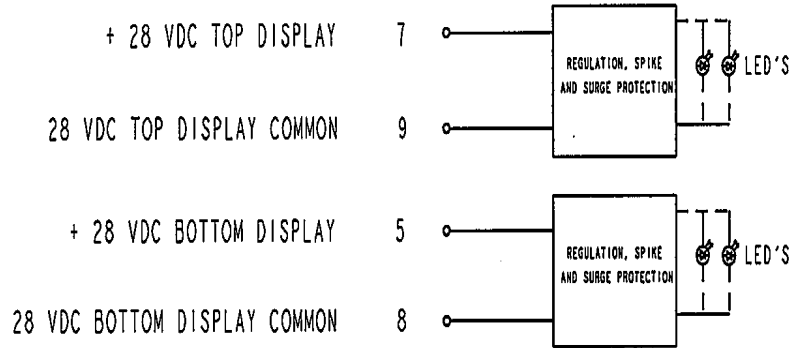

LED and Incandescent PWM Dimming

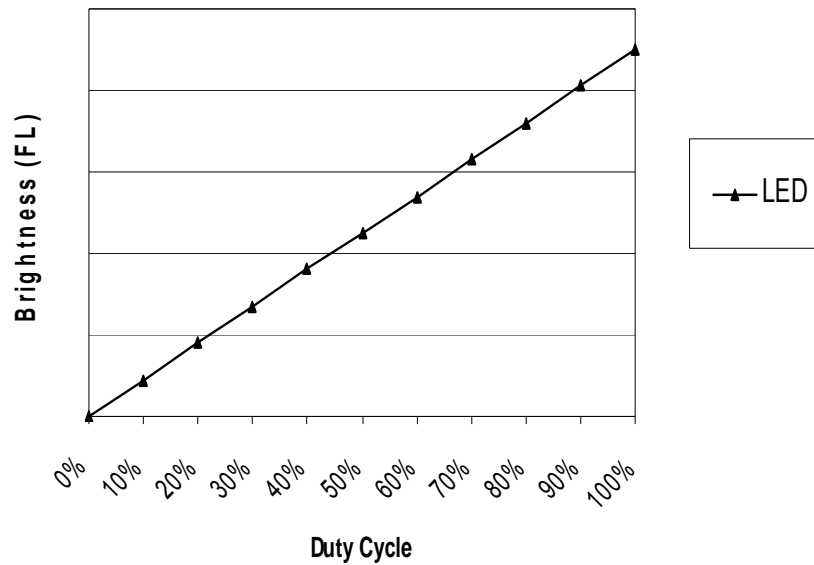

$$\text{PWM Brightness} = [\text{PWM Duty Cycle}\%] \times [\text{Brightness @100\% PWM}]$$

5. Programmable Dimming: This method requires a variable voltage power supply. The customer specifies the illumination level specific voltages, i.e. 28 VDC for 350 fL, 21 VDC for 200 fL, 14 VDC for 15 fL and 10 VDC for 1 fL. KORRY can program the micro controller to match most voltage vs. illumination characteristic dimming curves.

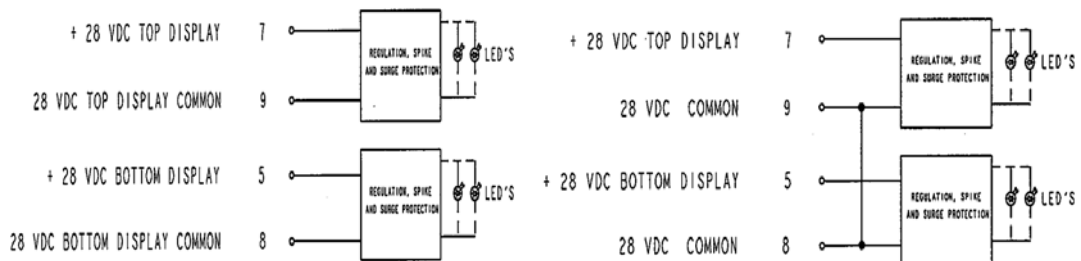
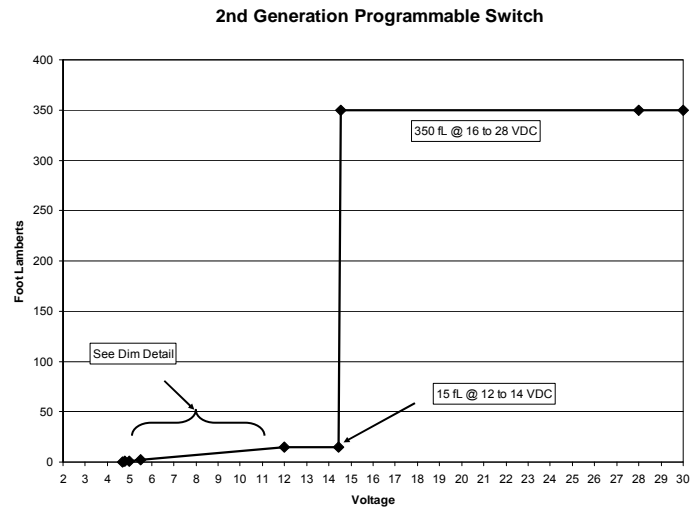
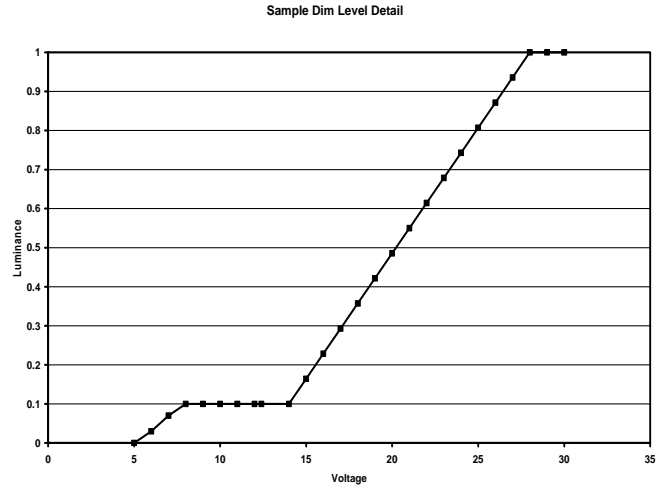

Product Configuration

Lens Configuration

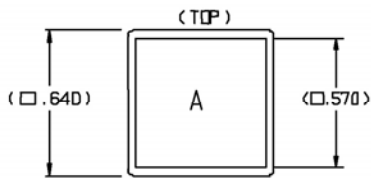

FULL DISPLAY
LENS CONFIG. 1

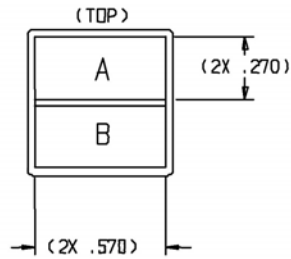

2-WAY
SPLIT DISPLAY
(HORIZONTAL)
LENS CONFIG. 2

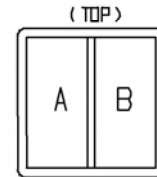

2-WAY
SPLIT DISPLAY
(VERTICAL)
LENS CONFIG. 3

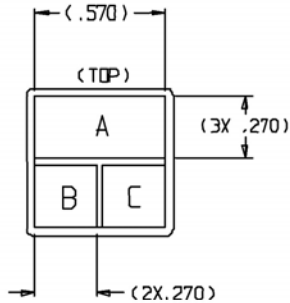

3-WAY
SPLIT DISPLAY
LENS CONFIG. 4

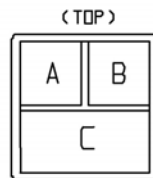

3-WAY
SPLIT DISPLAY
LENS CONFIG. 5

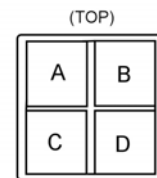

4-WAY
SPLIT DISPLAY
LENS CONFIG. 6

Operational Characteristics

Switch type: momentary or alternate action; four poles; double throw; Form C single break microswitch, in accordance with MIL-PRF-8805

Total cap travel: 0.165 inch (4.19 mm)

Actuation force: 2-5 pounds (0.91-2.27 kg)

Cap extraction: 2-5 pounds (0.91-2.27 kg)

Mounting torque: 16-20 inch-ounces

Actuation life: 100,000 cycles

Temperature: -55°C to +85°C

Flip Guard Configurations

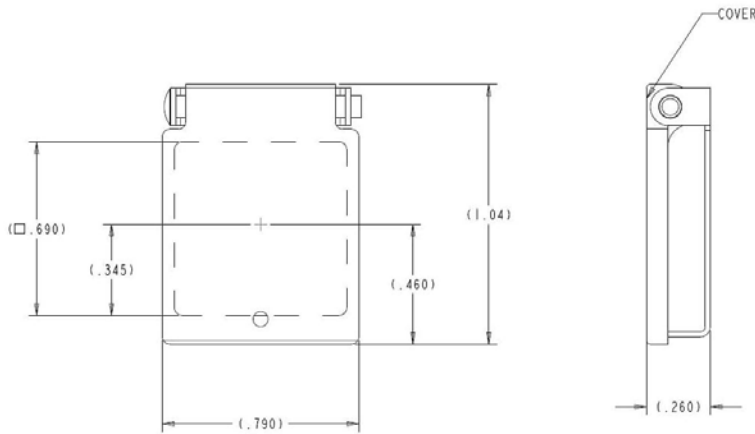

39442 – Clear, Painted, or Acrylic Cover

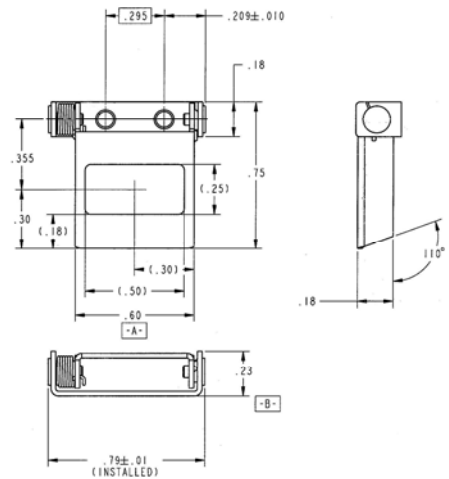

17378 – Metal Stay Open

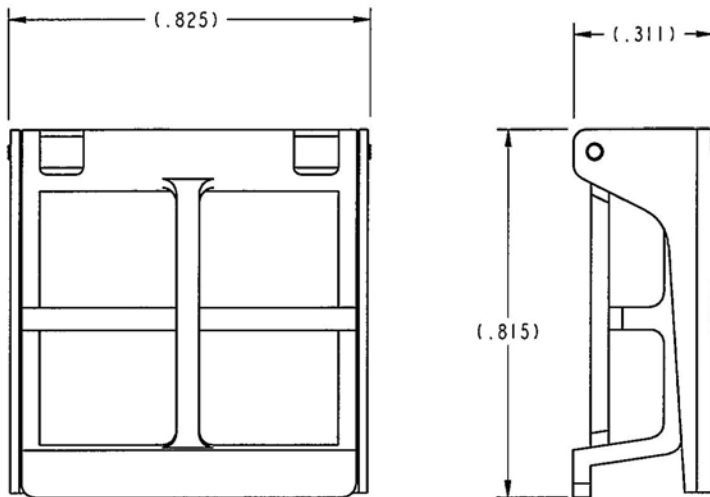

33982 – Metal 4 Way Cover

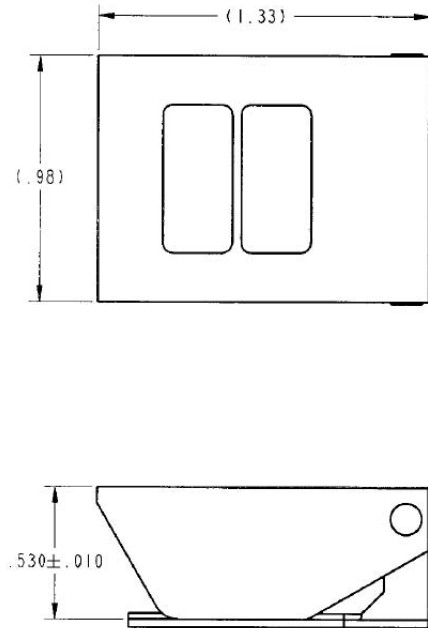

25399 – Metal Mushroom Cap

The 389 product line comes with a variety of flip guard configurations and options to prevent inadvertent switch actuation. The most common configuration is the acrylic cover which can be transparent, colored, or perimeter painted to distinguish it from adjacent flip guards. A metal flip guard is also available for four-way switches or for a mushroom cap switch. KORRY can also supply flip guards that have cover to frame detents that allow the cover to stay open after cover rotation. KORRY engineering can supply any flip guard design required for the specific application.

PC Header Configurations

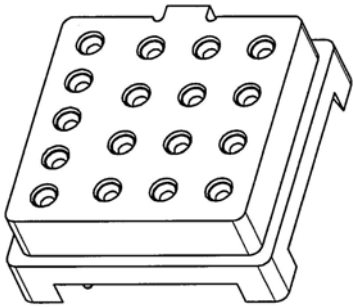

38803-001 – 5 Pin Rigid CCA

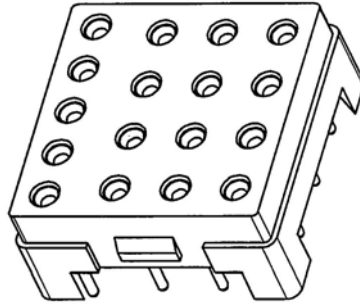

38803-002 – 5 Pin Flex CCA

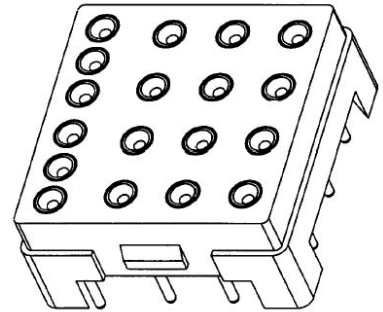

27493-001 – 6 Pin Flex CCA

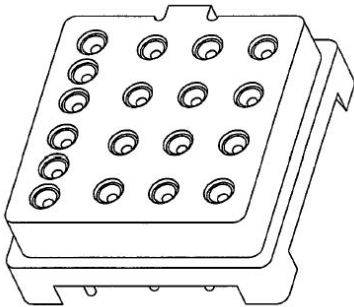

33463-001 – 6 Pin Rigid CCA

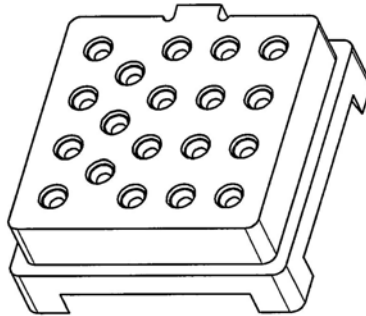

38803-003 – 7 Pin Rigid CCA

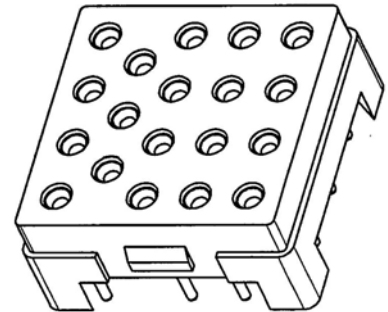

38803-004 – 7 Pin Flex CCA

The 389 product line comes with a variety of electrical interface options. The most commonly used interface option is the poke-home connector module as shown on the following pages. A different option to the poke-home connector module interface is the PC header electrical interface which can be used with a flex CCA or a rigid board CCA. The PC header interface options contain sockets that provide for a high reliability connection with the PC pins on the switches. The PC header interface option is available in 5-pin, 6-pin, or 7-pin versions.

Single Sleeve Mounting, 6 Pin, Standard Cap Configuration

NOTE: Mushroom cap option is also available.

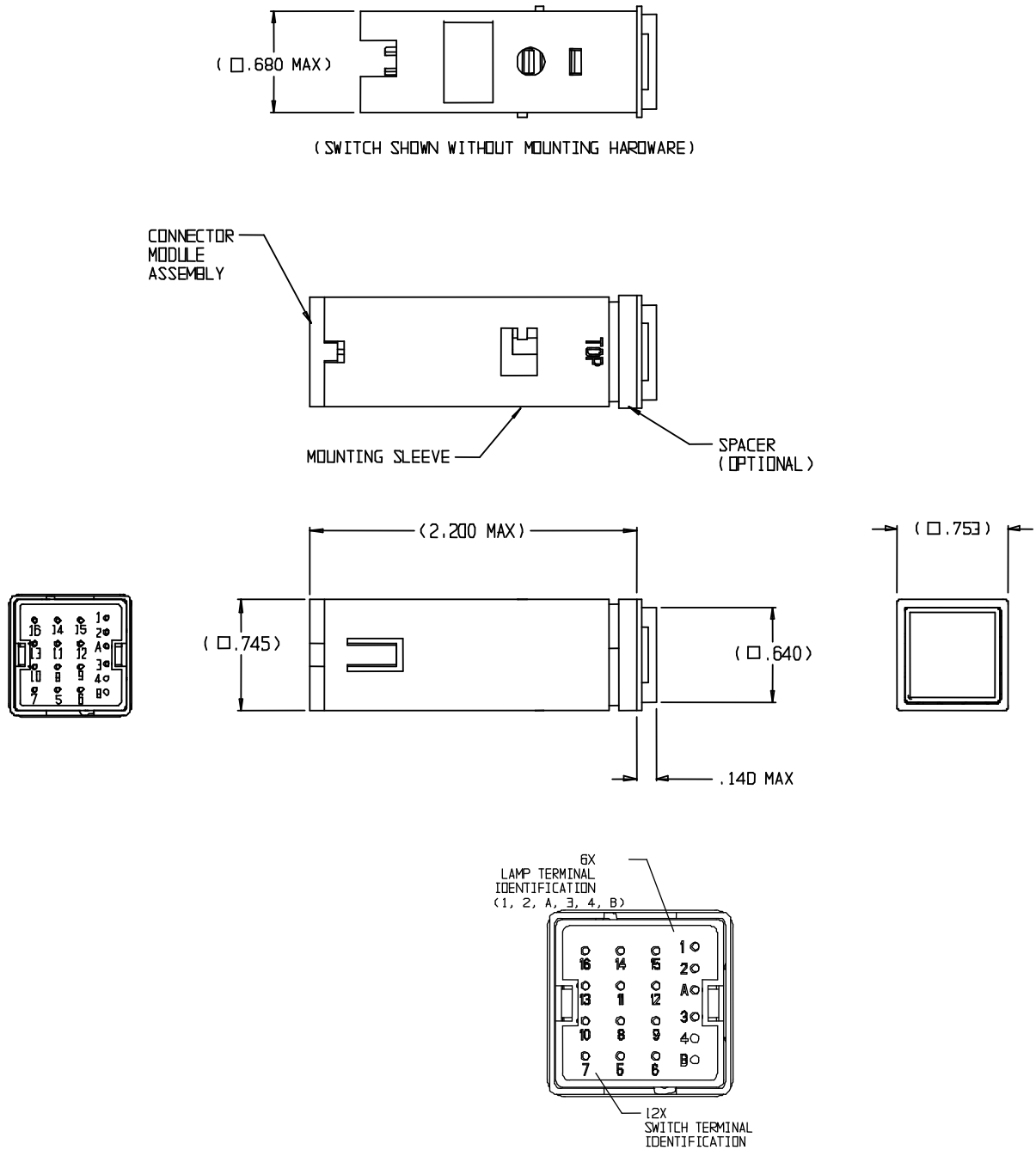

Parts List	Weight (Max)
Indicator Momentary Alternate	23g
Connector Module and Mounting Sleeve	12g
Flip Guard	3g

Double Sleeve Mounting, 6 Pin, Standard Cap Configuration

NOTE: Mushroom cap option is also available.

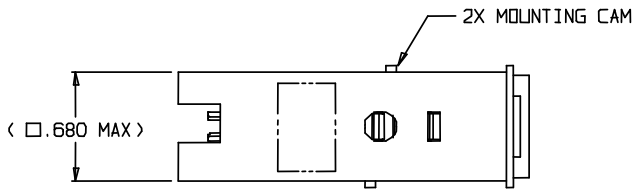

< SWITCH SHOWN WITHOUT MOUNTING HARDWARE >

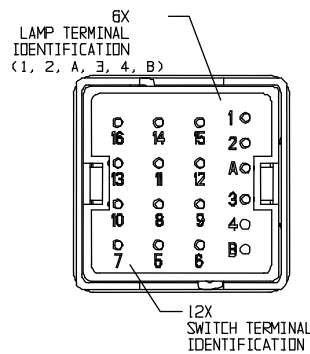
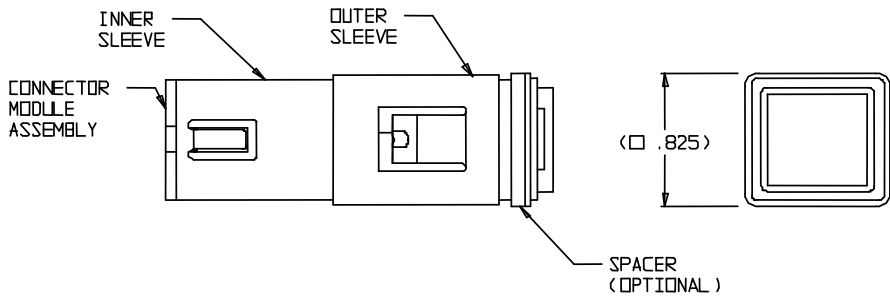
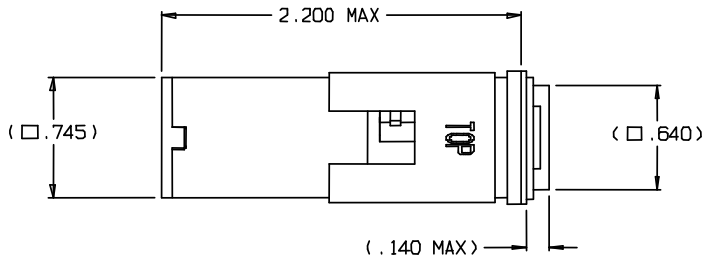

Parts List	Weight (Max)
Indicator Momentary Alternate	23g
Connector Module and Mounting Sleeve	13g
Flip Guard	3g

Double Sleeve Mounting, 5 Pin, Standard Cap Configuration

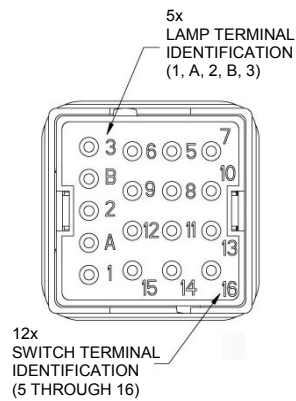
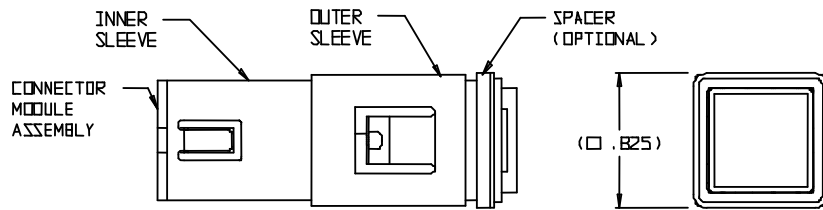
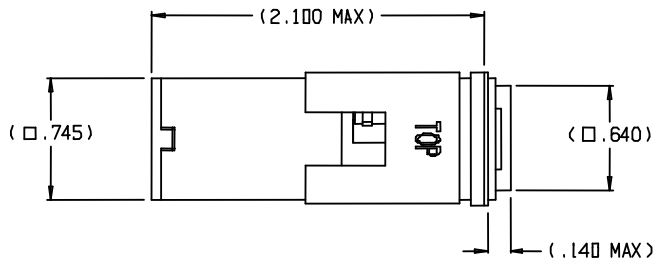
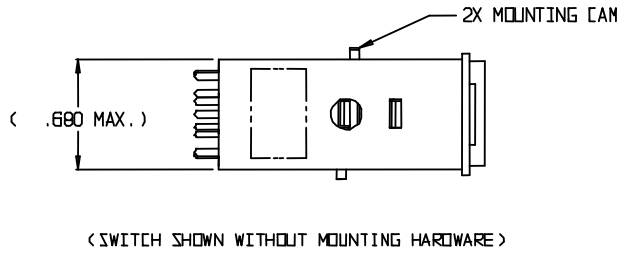

Parts List	Weight (Max)
Indicator Momentary Alternate	23g
Connector Module and Mounting Sleeve	13g
Flip Guard	3g

Double Sleeve Mounting, 5 Pin, Mushroom Cap Configuration

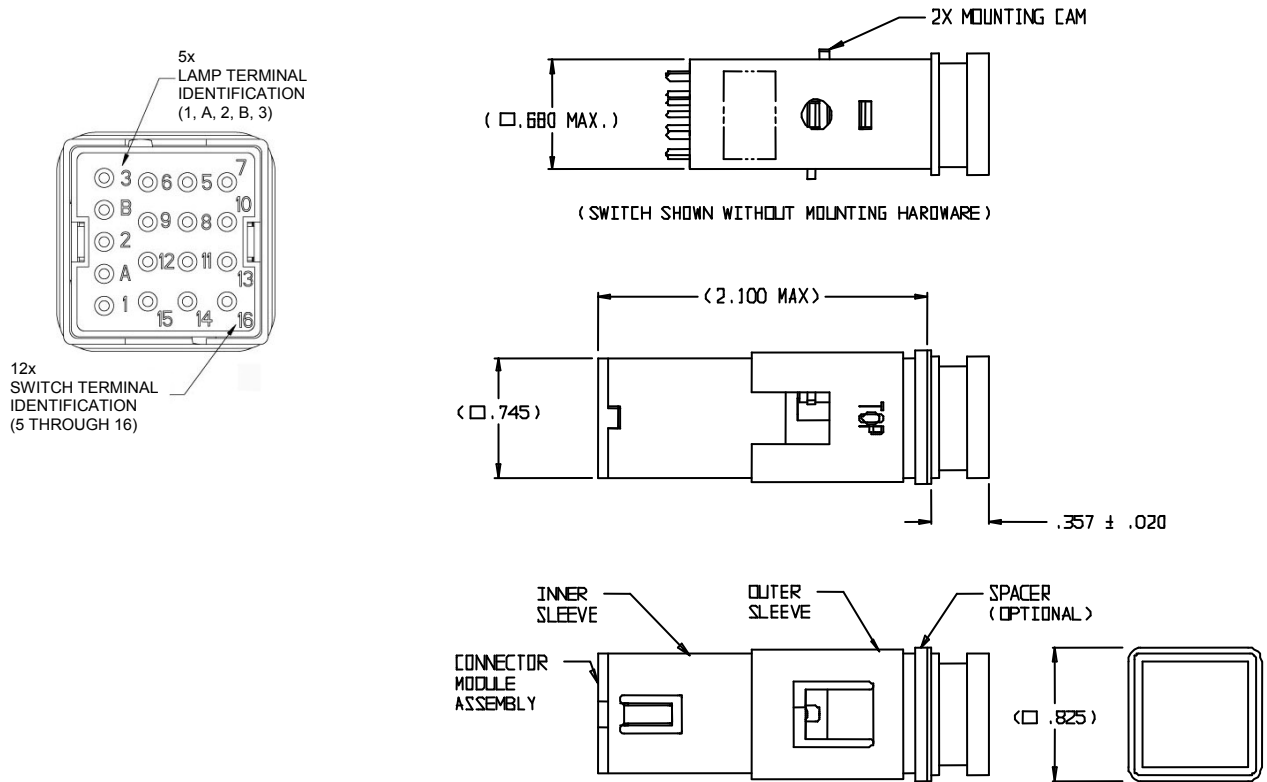

NOTE: Legend area for mushroom cap is the same as all other 389 cap versions.

Parts List	Weight (Max)
Indicator Momentary Alternate	23g
Connector Module and Mounting Sleeve	13g
Flip Guard	3g

Universal Sleeve Mounting, 5 Pin, Standard Cap Configuration

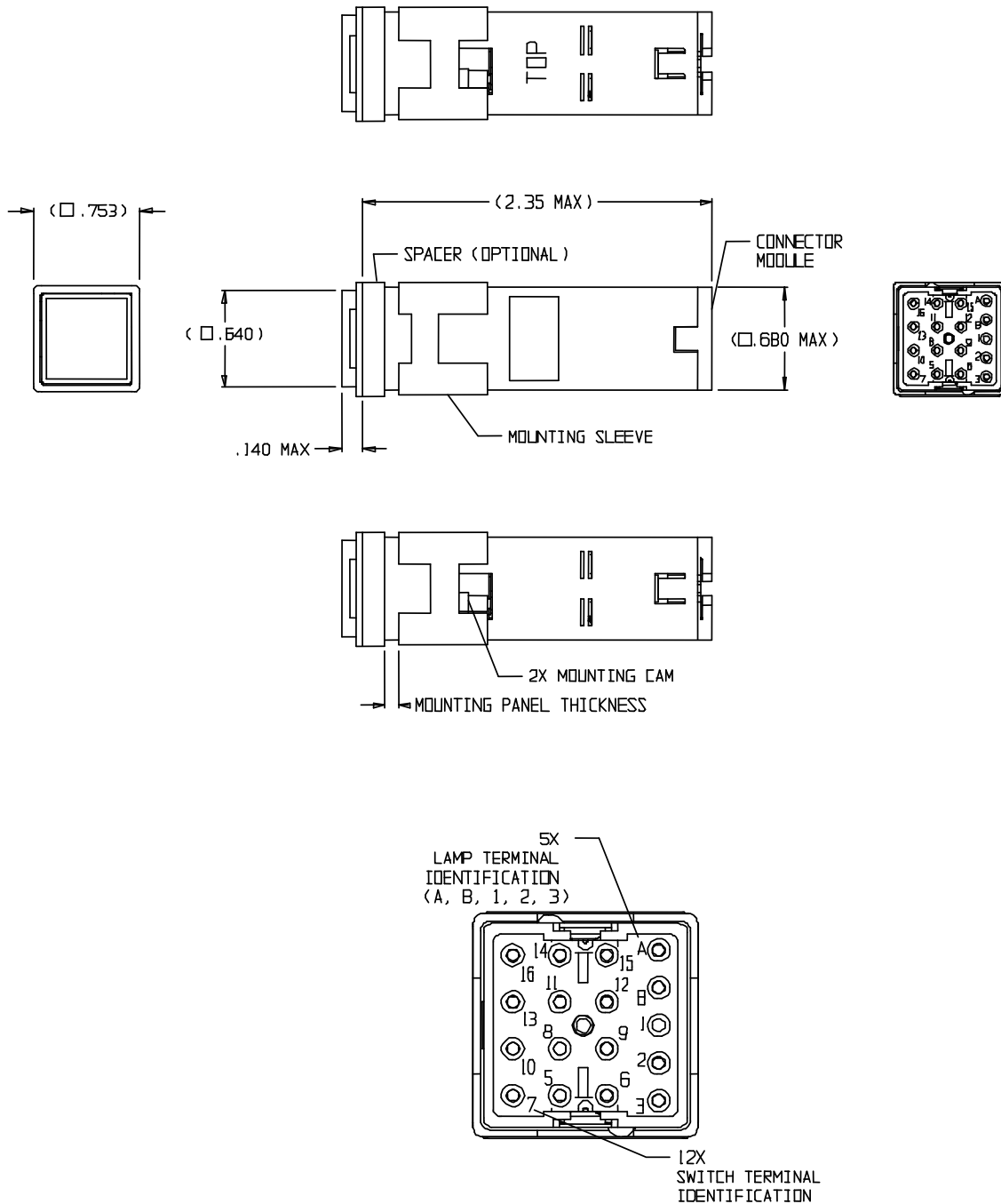

Parts List	Weight (Max)
Indicator Momentary Alternate	23g
Connector Module and Mounting Sleeve	13g
Flip Guard	3g

External Seal

(Available in both 5-pin (shown) and 6-pin terminations.)

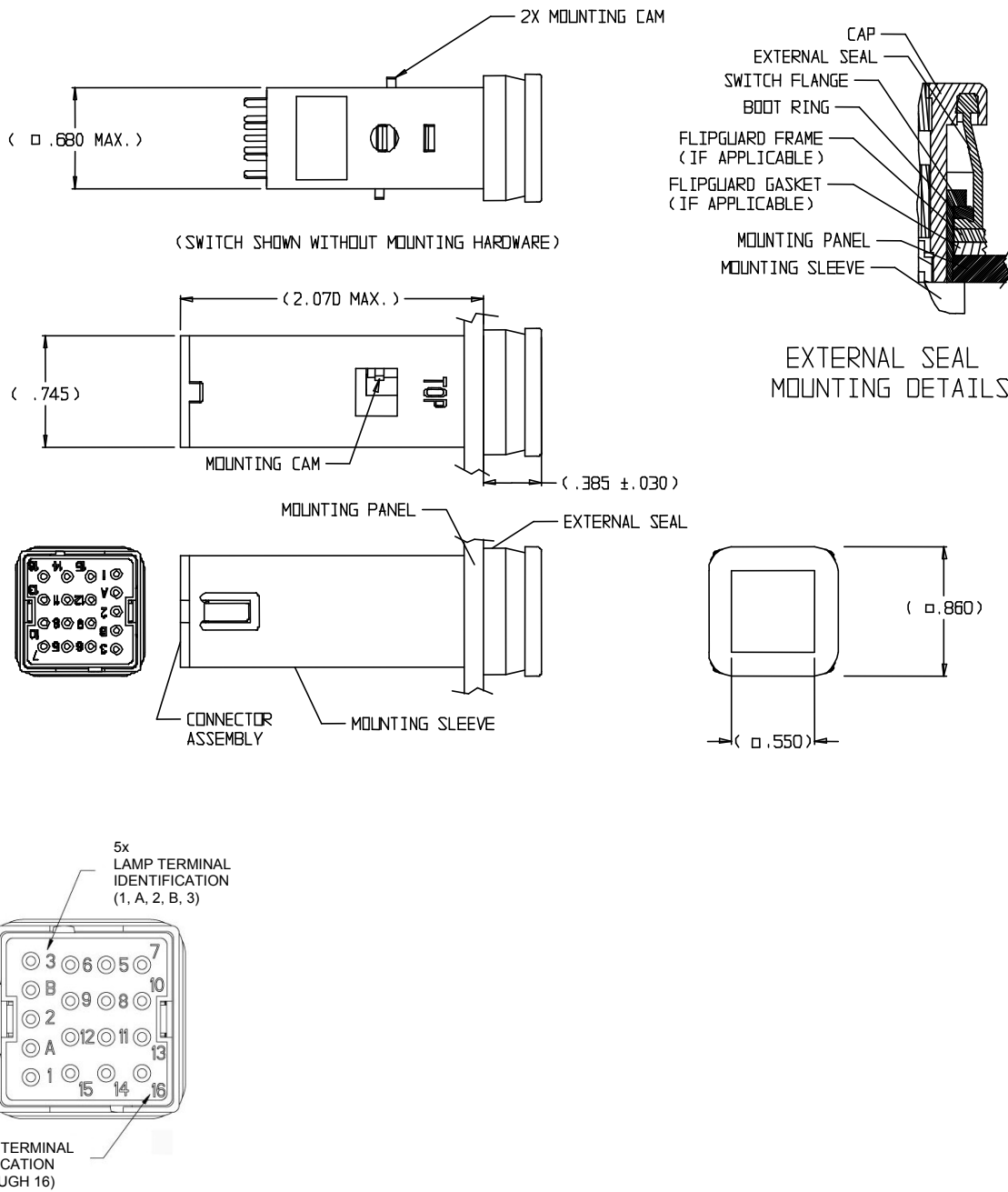

EXTERNAL SEAL MOUNTING DETAILS

Parts List	Weight (Max)
Indicator Momentary Alternate	23g
Connector Module and Mounting Sleeve	13g
Flip Guard	3g

Magnetic Latch, Standard Cap Configuration

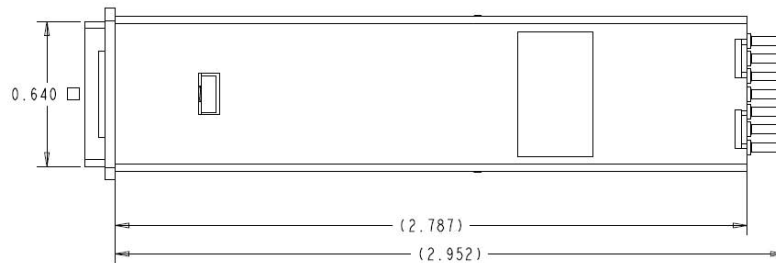
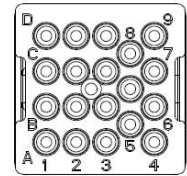
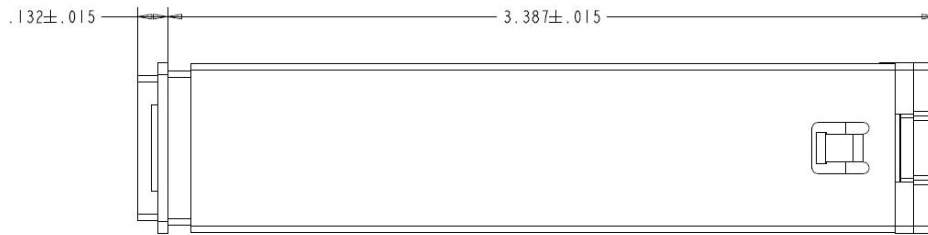

Parts List	Weight (Max)
Indicator Momentary Alternate	35g
Connector Module and Mounting Sleeve	13g
Flip Guard	3g

Magnetic Latch, Sealed Cap Configuration

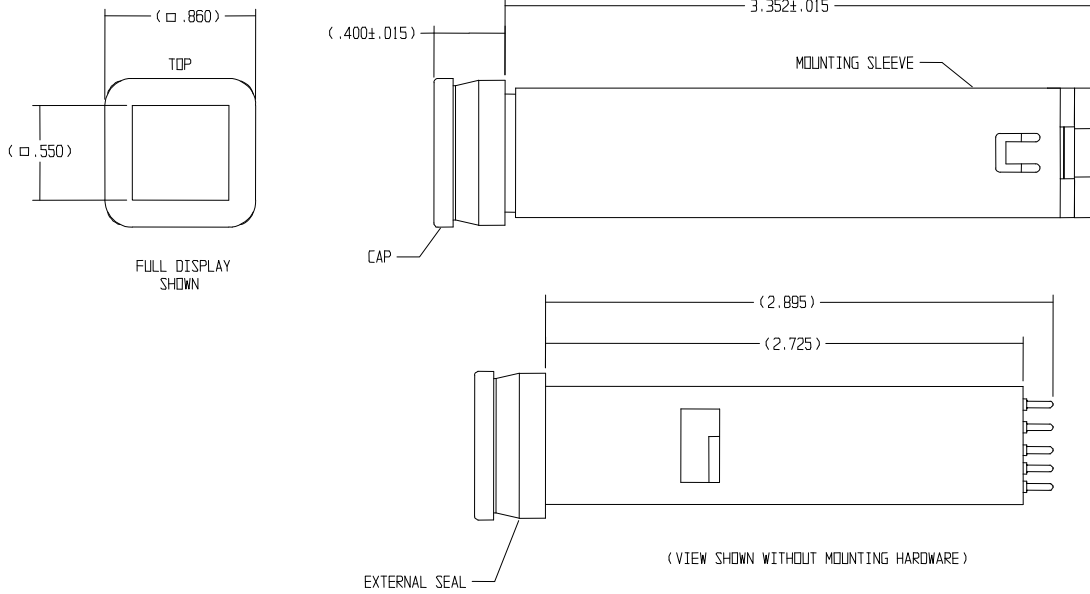

SWITCH ASSEMBLY

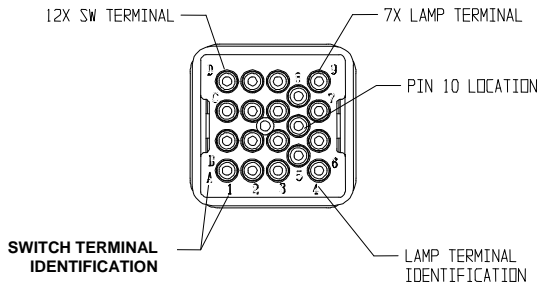

Parts List	Weight (Max)
Indicator Momentary Alternate	35g
Connector Module and Mounting Sleeve	13g
Flip Guard	3g

Magnetic Latch, Short Body, Standard Cap Configuration

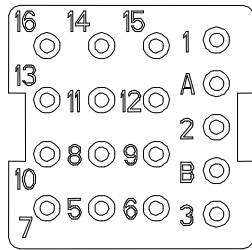
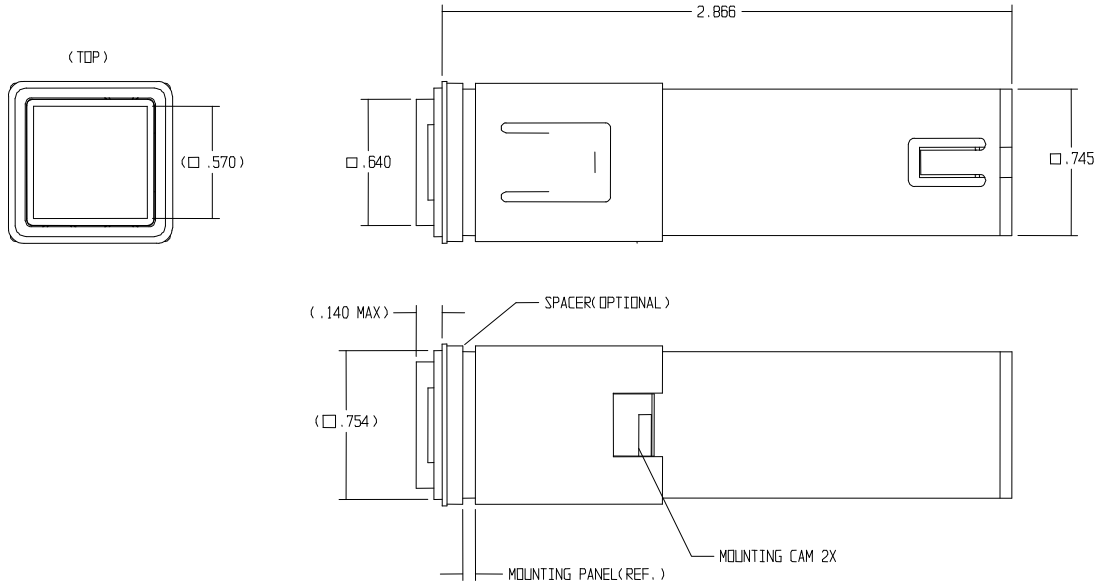

CONNECTOR PIN OUT IDENTIFICATION

Parts List	Weight (Max)
Indicator Momentary Alternate	30g
Connector Module and Mounting Sleeve	13g
Flip Guard	3g

1380 5-Pin Configuration

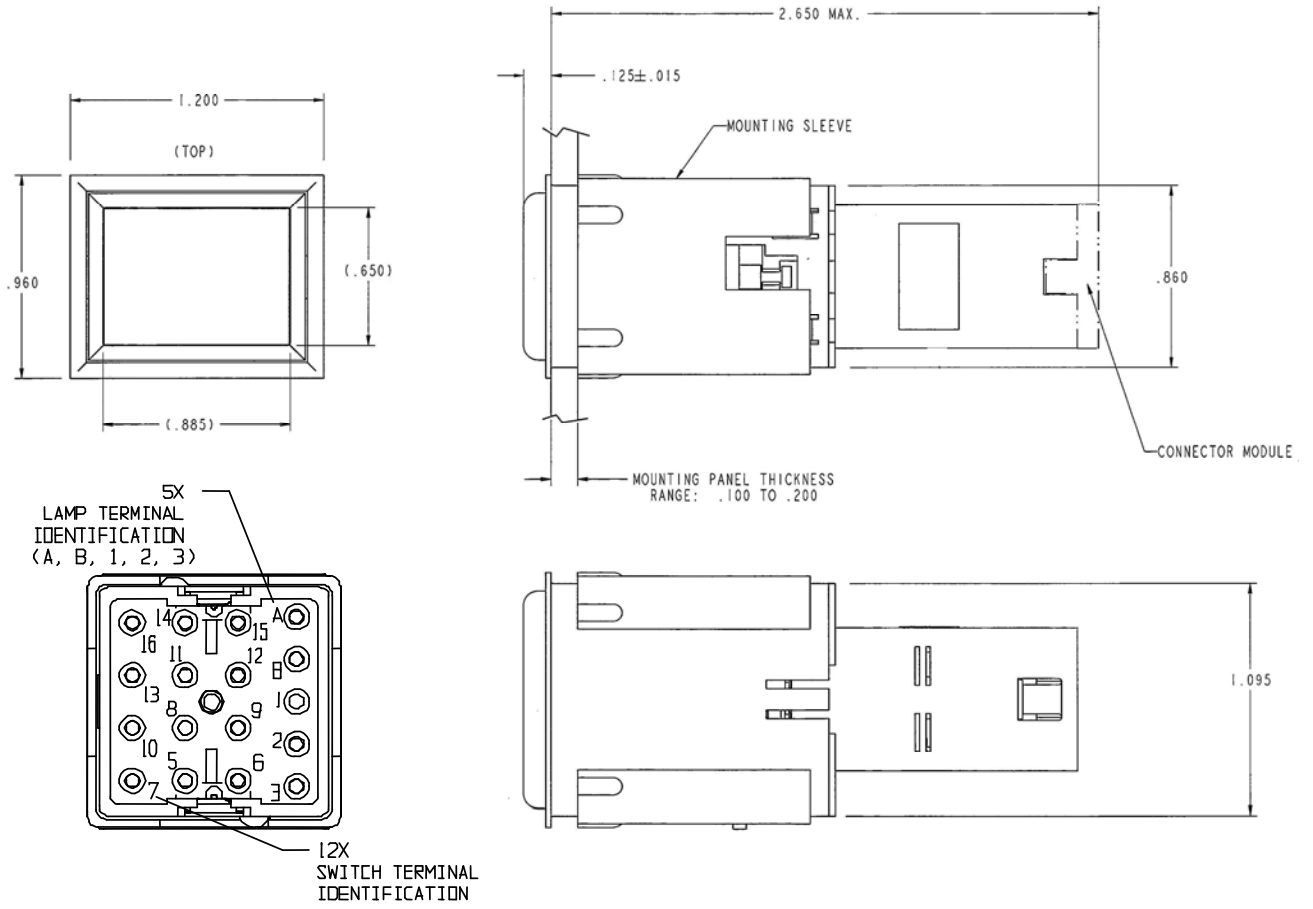

Parts List	Weight (Max)
Indicator Momentary Alternate	44.5g
Connector Module and Mounting Sleeve	12g
Flip Guard	3g

Electrical

Schematic Diagrams



FULL DISPLAY

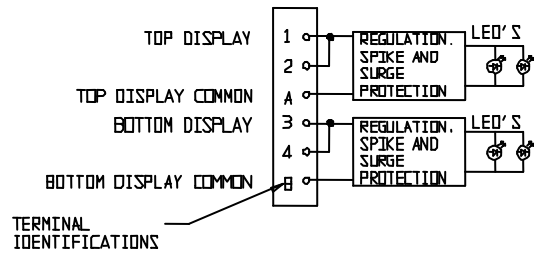

HORIZONTAL SPLIT DISPLAY

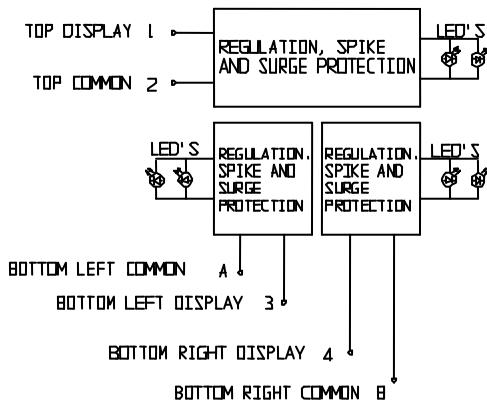

3-WAY SPLIT DISPLAY

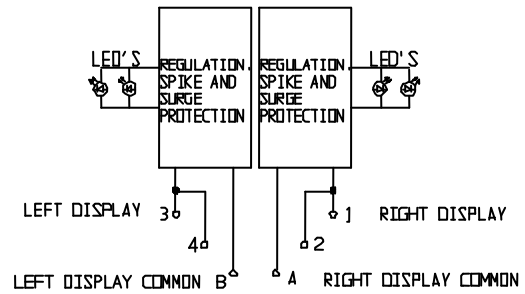

VERTICAL SPLIT DISPLAY

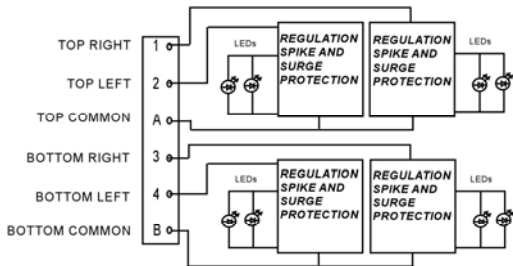

4-WAY 2 COMMON SPLIT DISPLAY

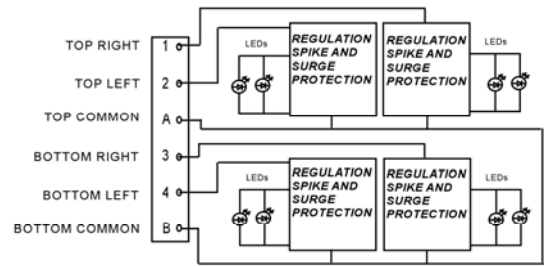

4-WAY 1 COMMON SPLIT DISPLAY

6-Pin Lamp Circuit

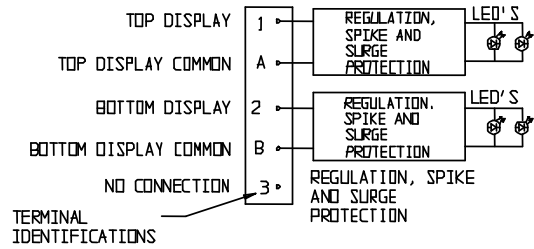
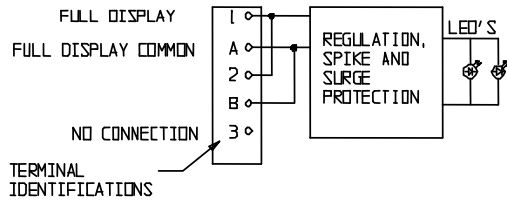

FULL DISPLAY

HORIZONTAL SPLIT DISPLAY

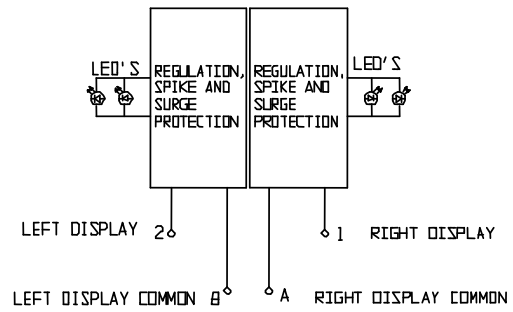
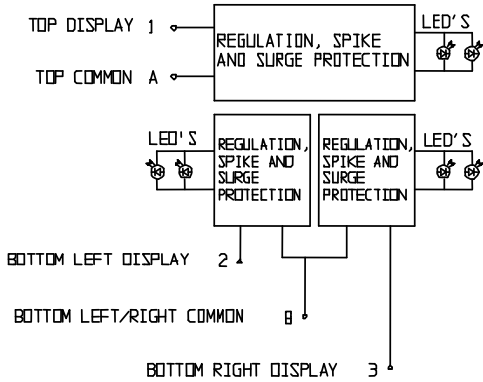

3-WAY SPLIT DISPLAY

VERTICAL SPLIT DISPLAY

5-Pin Lamp Circuit
(Except Quick Switch and universal sleeve configuration)

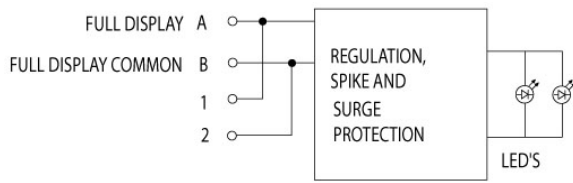

FULL DISPLAY

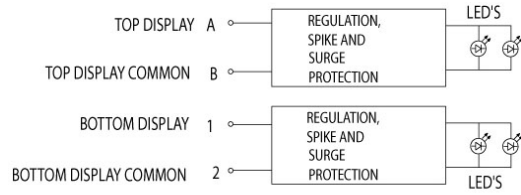

HORIZONTAL SPLIT DISPLAY

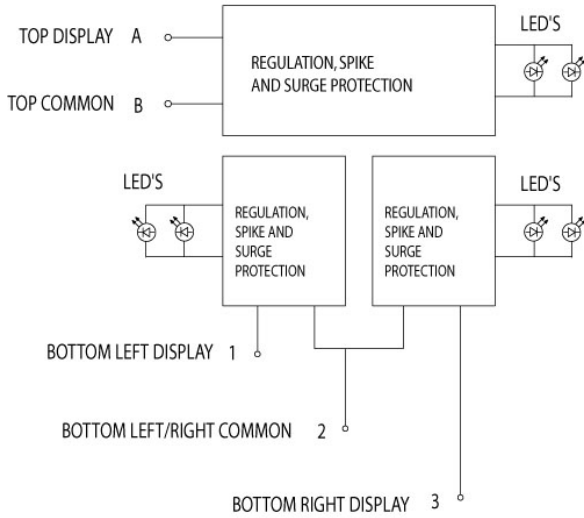

3 WAY SPLIT DISPLAY

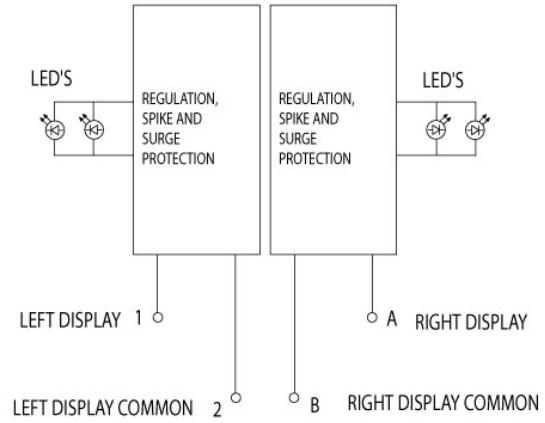

VERTICAL SPLIT DISPLAY

5-Pin Lamp Circuit

*Quick Switch and
Universal sleeve configuration*

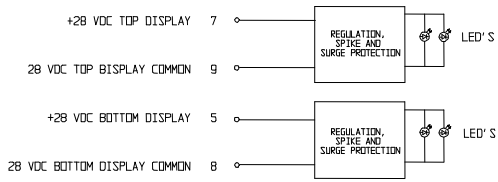

(SPLIT SCHEMATIC CIRCUIT DIAGRAM)

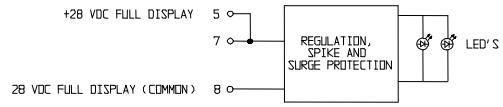

(FULL SCHEMATIC CIRCUIT DIAGRAM)

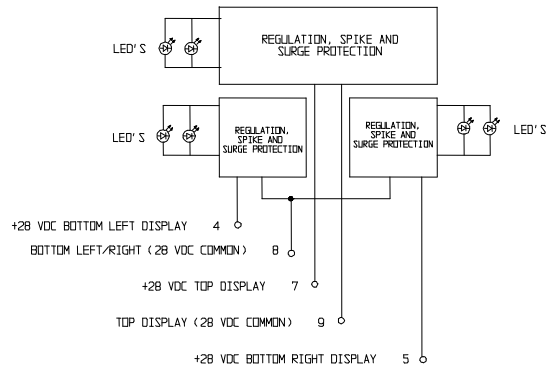

(THREE WAY SCHEMATIC CIRCUIT DIAGRAM)

Magnetic Latch Lamp Circuit

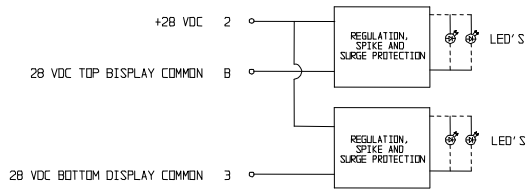

(SPLIT DISPLAY)

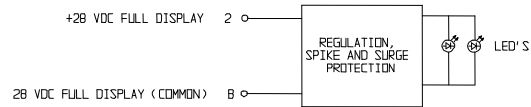

(FULL DISPLAY)

Short Magnetic Latch Lamp Circuit

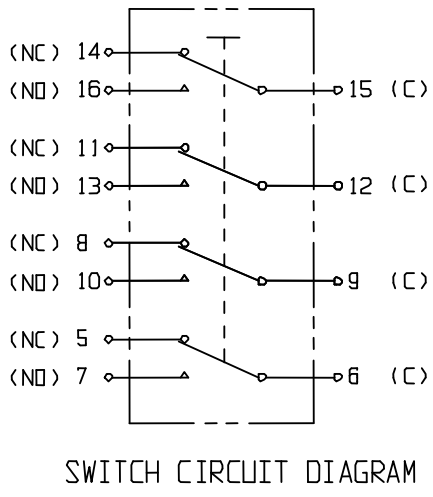

Switch Circuit

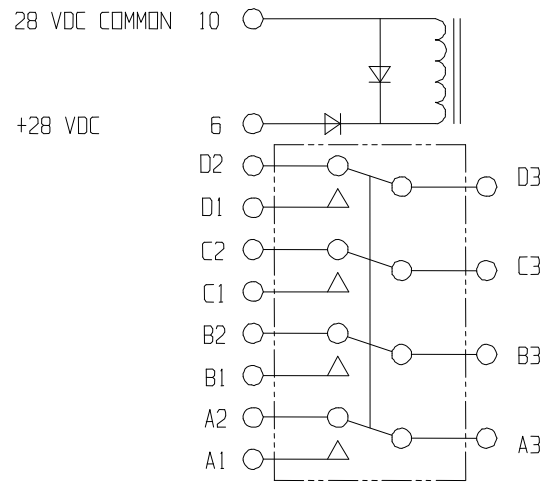

Magnetic Latch Switch Circuit

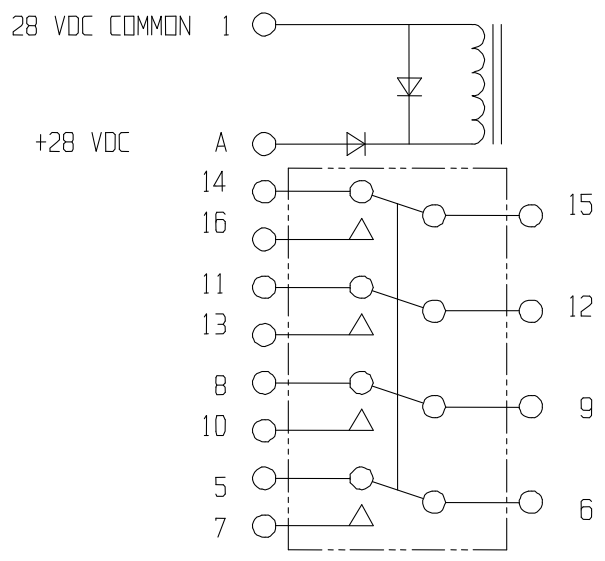

Short Magnetic Latch Switch Circuit

NOTE: Switch and lamp terminal designations may be modified.

Electrical Interface

Removable connector module accepts M39029/57-354 (6-pin) or M39029/22-192 (5-pin) crimp sockets. (See installation instructions for tool part number).

Switch Contact Ratings

Load	Electrical Rating in Amperes at 28 VDC	
	Sea Level	50,000 Feet
Resistive	8 A	4 A
Inductive	4 A	2.5 A
Lamp	2.5 A	2.5 A

Switch may be used on low-level applications. In order to retain their "low current" quality, contacts must switch a current between 1mA and 100mA under low voltage. When subjected to high currents, contacts can lose their low current performance.

Optical

Uniformity

Displays typically meet 2 to 1 uniformity character to character. Text size and length can impact product uniformity.

Photometric Brightness

The table below lists the required brightness (luminance) values when measured at maximum display voltage.

Luminance Values

<i>Legend Type</i>		Color	Minimum Brightness in Foot-Lamberts	<i>Legend Type</i>		Color	Minimum Brightness in Foot-Lamberts
MIL-PRF-22885 Designation	KORRY Designation			MIL-PRF-22885 Designation	KORRY Designation		
N	2G2*	Amber	60	W	2D	Amber	60
		Red	60			Red	60
		Green	60			Green	60
		White	60			White	60
		Blue	30			Blue	30
S	1B	Amber	200	N/A	2F	Amber	150
		Red	200			Red	150
		Green	200			Green	150
		White	200			Blue	40
		Blue	50				
B or C	1C or 2B	Amber	150				
		Red	150				
		Green	150				
		White	150				
		Blue	40				

* Minimum value is not typical for this type of display. Generally, type N displays are used for night visibility and are designed to match the light-plate luminance value.

Contrast

The table below lists the required legend average contrast values when measured at maximum display voltage.

Contrast Values

<i>Legend</i>		ON Contrast	Off Contrast
<i>Type</i>	Color	(Minimum)	(Maximum)
S(1B)	Amber	0.6	±0.1
	Red	0.6	±0.1
	Green	0.6	±0.1
	White	0.6	±0.1
	Filtered White	0.6	±0.1
	Light Blue	0.6	±0.1

Chromaticity

The average color coordinates shall be within the area outlined by the coordinate system specified in the table below, based on the 1931 CIE chromaticity diagram.

Standard Chromaticity Values

<i>Color</i>	x	y	<i>Color</i>	x	y
Red	.670	.334	Warm White	.390	.420
	.670	.310		.390	.370
	.695	.285		.460	.370
	.710	.292		.460	.420
Green	.20	.64	White	.280	.270
	.20	.74		.280	.370
	.32	.74		.340	.370
	.32	.64		.340	.270
Amber	.565	.440	Light Blue	.140	.250
	.605	.395		.140	.150
	.593	.382		.200	.150
	.562	.415		.200	.250

NVIS Colors

MIL-STD-3009 or MIL-L-85762A

NVIS Compatibility

KORRY NVIS products meet the requirements of MIL-L-85762A and MIL-STD-3009.

Legend Types

OFF
CONDITION

ON
CONDITION

S (1B)

HIDDEN LEGEND. LETTERS NOT VISIBLE UNTIL ILLUMINATED. LIGHTED COLORED LETTERS ON OPAQUE BLACK BACKGROUND WHEN ENERGIZED.

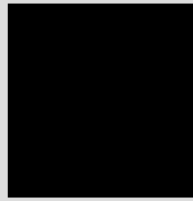

B (1C)

HIDDEN LEGEND. LETTERS NOT VISIBLE UNTIL ILLUMINATED. LIGHTED COLORED BACKGROUND WITH OPAQUE BLACK LETTERS WHEN ENERGIZED.

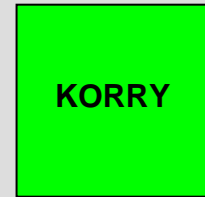
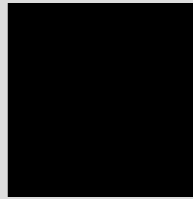

W (2D)

OPAQUE BLACK LETTERS ON WHITE BACKGROUND. BACKGROUND SHOWS COLOR WHEN ENERGIZED.



N (2G2)

WHITE LETTERS ON OPAQUE BLACK BACKGROUND. LETTERS SHOW COLOR WHEN ENERGIZED.

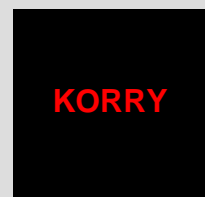

C (2B)

OPAQUE BLACK LETTERS ON COLORED BACKGROUND. LIGHTED COLORED BACKGROUND WHEN ENERGIZED.



(2F)

OPAQUE WHITE LETTERS ON DARK BACKGROUND. BACKGROUND SHOWS COLOR WHEN ENERGIZED.

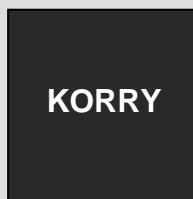

Font Types and Sizes vs. Character Capacities

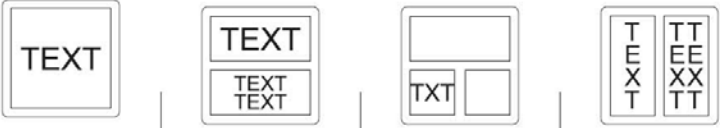

		Number of lines	Number of Characters per line	Number of lines	Number of Characters per line	Number of lines	Number of Characters per line	Number of lines	Number of Characters per line
Futura Medium	Char Ht. .093	1-4	6	1-2	6	1	2	1	4
	Char Ht. .125	1-3	4	1	4	1	2	1	3
Futura Medium Condensed	Char Ht. .093	1-4	9	1-2	9	1	3	1-2	4
	Char Ht. .125	1-3	7	1	7	1	3	1	3
Helvetica Medium	Char Ht. .093	1-4	5	1-2	5	1	2	1	4
	Char Ht. .125	1-3	4	1	4	1	2	1	3
Helvetica Medium Condensed	Char Ht. .093	1-4	7	1-2	7	1	3	1	4
	Char Ht. .125	1-3	5	1	5	1	2	1	3
GORTON NORMAL	Char Ht. .093	1-4	6	1-2	6	1	2	1	4
	Char Ht. .125	1-3	4	1	4	1	2	1	3
GORTON CONDENSED	Char Ht. .093	1-4	7	1-2	7	1	3	1-2	4
	Char Ht. .125	1-3	5	1	5	1	2	1	3
GORTON EXTRA CONDENSED	Char Ht. .093	1-4	9	1-2	9	1	3	1-2	4
	Char Ht. .125	1-3	7	1	7	1	2	1	3
News Gothic	Char Ht. .093	1-4	6	1-2	6	1	2	1-2	4
	Char Ht. .125	1-3	5	1	5	1	2	1	3
DIN 1451 Mittelschrift	Char Ht. .093	1-4	6	1-2	6	1	2	1	4
	Char Ht. .125	1-3	4	1	4	1	2	1	3
DIN 1451 Engshrift	Char Ht. .093	1-4	9	1-2	9	1	3	1-2	4
	Char Ht. .125	1-3	6	1	6	1	2	1	3

Number of characters per line can vary depending upon characters selected.

Environmental

389 Qualification Summary		
Test Name	Specification	Summary
Contact Resistance	MIL-STD-202F, Method 307	The average contact resistance shall not exceed 25 mΩ.
Contact Bounce	MIL-PRF-22885F, 4.7.5	The switch is mechanically operated at a velocity 200 ± 40 mm per second. The contacts under test shall be closed five times. The duration of the contact bounce shall be less than 10 μ seconds. Any contact bounce which exceeds the maximum value specified shall constitute failure. The test is repeated until all sets of contacts have been measured for contact bounce.
Touch Temperature	MIL-S-22885/109A	Touch temperature shall not exceed 45° F
Permanency of Marking	MIL-STD-202F, Method 215J	Test samples are subject to solvents. Markings which are missing in whole or in part, faded, smeared, blurred, or shifted to the extent they cannot be readily identified from a distance of at least 0.1524 meters with normal room lighting without the aid of magnification or with a viewer having a magnification no greater than 3X shall constitute failure.
Strength Of Actuating Means	MIL-PRF-22885F, 4.7.10	After an application of 25 lbs. of force for 60-sec, there shall be no damage that will interfere with the electrical or mechanical performance of the unit.
Thermal Shock	MIL-STD-202F, Method 107G, Condition A	Thermal cycle from -55°C to +85°C, 30 minutes each, 5 times. After testing the cap shall illuminate and there shall be no discoloration or mechanical /electrical damage that interferes with the operation of the unit.
Vibration	MIL-STD-810C, Method 514.2, Category B2, Procedure 1A	Functional PDF of 0.004 G ² /Hz, from 8 Hz to 2000 Hz, Endurance PDF of 0.040 G ² /Hz, from 8 Hz to 2000 Hz. Functional performed for 30 min, endurance for 1 hour, followed by another functional for 30 min. No electrical discontinuity in excess of 50msec, no chatter in excess of 10μsec allowable during random vibration.
Shock	MIL-STD-202F, Method 213B, Condition B	Pulse duration shall be 6 ms and an acceleration of 75 g. A total of 18 pulses are applied. The LEDs shall experience no electrical discontinuity in excess of 50 ms during the shock pulses. The switch contacts shall experience no chatter in excess of 10 μs during the shock pulses.
Moisture Resistance	MIL-STD-202F, Method 106F	With the test samples mounted at 15° from the normal horizontal, the unit is subjected to 25° C ambient and 90% to 100% relative humidity. Insulation resistance shall be at least 10 MΩ when tested within 5 min. after removal from the chamber. Insulation resistance shall be at least 1000 MΩ after a 24-hour drying period. There shall be no corrosion, breaking, cracking, or spalling, and mounting hardware shall be readily removable. Excessive corrosion is defined as that which interferes with the electrical or mechanical performance and has penetrated the plating and has attacked the base material.
Insulation Resistance	MIL-STD-202F, Method 302, condition B	
Dielectric Withstand Voltage	MIL-STD-202F, Method 301 and Method 105C, condition B	Dielectric withstand is checked between all pins and the case, then between mutually isolated circuits. 1000 Vac at a rate of 500 Vac per second is applied with the threshold set at 500μA. The voltage is held at maximum for 60 sec. Reduced atmospheric pressure is tested in an altitude chamber set for 50000 feet. (1.70 psia). This is tested with 400 Vac for 60 sec. With a threshold of 500μA.

389 Qualification Summary

Test Name	Specification	Summary
Salt Spray	MIL-STD-202F, Method 101D, Condition A	<p>The test specimen is set in a salt spray chamber conditioned as follows:</p> <ul style="list-style-type: none"> • Collection rate of 0.5 to 3.0 ml per hour for each 80 cm² of horizontal collecting area. • The pH of the salt solution must be 6.5 to 7.2 when measured at a temperature of 35°C. • The specific gravity of the salt solution must be 5 ±1% when measured at a temperature of 35°C. <p>There shall be no evidence of warping, cracking, excessive corrosion or other damage. Excessive corrosion is defined as that which interferes with the electrical or mechanical performance and has penetrated the plating and has attacked the base material.</p>
Explosion	MIL-STD-202F, Method 109B	<p>The unit operating at 30.3 Vdc within a 71° ± 3°C environment. The fuel used to form an explosive atmosphere shall be aviation gasoline, grade 100/130, conforming to Military Specification MIL-G-5572. The fuel weight necessary to produce an air-vapor ratio of 13 to 1 at the desired altitude shall be determined from consideration of chamber volume, fuel temperature and specific gravity, chamber-air and wall temperature, test altitude, etc. A time of 3 ± 1 minute shall be allowed for introduction and vaporization of the fuel. Air shall be admitted into the chamber until a simulated altitude of 5000 feet above the test altitude is attained. At this time the potential explosiveness of the resulting air-vapor mixture shall be verified. Simulated test altitudes are 50000, 40000, 30000, 20000, 10000, and 5000 feet. The test specimen is actuated several times in this atmosphere. Operation of the test specimen shall not generate an electrical arc sufficient to ignite the explosive atmosphere. The test specimen shall operate electrically and mechanically at the conclusion of the test at normal operating voltage.</p>
Sand and Dust	MIL-STD-202F, Method 110A	<p>The legends shall remain illuminated while exposed to dust. The samples shall operate electrically and mechanically following exposure to the fine dust by completing operating characteristic checks. The dust simulates sharp edged particles up to 150 microns in size.</p>
Overload Cycling	MIL-PRF-22885F, 4.7.27	<p>Test specimens are subject to 7.5 A applied across the switch contacts. The unit completes 50 cycles at a rate of 6 CPM (12 CPM for alternate action). There shall be no electrical or mechanical failure.</p>
Electrical Endurance	MIL-PRF-22885F, 4.7.28	<p>Test specimens are subject to 5 A applied across the switch contacts. In an 85° C environment, the unit must complete 25000 cycles. No switch contact shall fail to open or close its individual circuit in the proper sequence. After the test, the switches shall be electrically and mechanically operative. The legends shall remain illuminated throughout the test and there shall be no deformation, melting, delaminating, blistering of the lens assembly, or legend illegibility following the test.</p>

389 Qualification Summary

Test Name	Specification	Summary
Mechanical Endurance	MIL-PRF-22885F 4.7.29	<p>Test specimens are subject to the following conditions at 100 CPM:</p> <ul style="list-style-type: none"> • 5000 cycles at -55° C • 10000 cycles at +85° C • 85000 cycles at room temperature (momentary) • 35000 cycles at room temperature (alternate action) <p>The cap assemblies shall operate mechanically and electrically upon completion of the test. No contact shall fail to close its individual circuit during the proper sequence. The caps shall show no evidence of damage such as sticking, loose latching of lens assembly, or broken/deformed clips or springs.</p>
Power	RTCA/DO-160D, 16 and 17, Category A	<p>Legends shall remain fully illuminated during the application of power. The brightness may vary with input voltage level but must automatically recover upon return to nominal voltage.</p> <ul style="list-style-type: none"> • Normal steady state voltage as follows: 30.3V (30 min), 22.0V (30 min), 18.0V (30 min) • Normal surge voltage as follows: Surges of 40Vdc applied for 30 msec followed by 15Vdc applied for 30 msec. The surges are applied to a unit running at 27.5Vdc ± 0.5V for 5 minutes before and between surges. Surges are applied 3 times in the sequence described. • Abnormal surge voltage as follows: With the equipment operating under normal voltage, 46.3Vdc for 100 msec and 37.8Vdc applied for 1 sec is injected to the positive input lead. Each voltage is applied 3 times at 10 sec. intervals. • Voltage spike as follows: Injection of 50 transient pulses of each polarity applied within a period of 1 min. Transient voltage is 600V. Waveform source impedance is 50Ω ±10%. Pulse rise time is ≤ 2μsec and total pulse duration is at least 10μsec. During these tests, there shall be no permanent damage, component failure, insulation breakdown, susceptibility degradation, or changes in equipment performance.
Audio Frequency Conducted Susceptibility	RTCA/DO-160D, 18, Category Z	<p>Frequency characteristics of Ripple shall meet the following profile:</p> <ul style="list-style-type: none"> • 0.01KHz to 0.02KHz = 0.2V • 0.02KHz to 1.0KHz = 0.56V • 1.0KHz to 15.0KHz = 1.4V • 15.0KHz to 150.0KHz = roll-off to 0.0015V at 150.0KHz
Magnetic Effect	RTCA/DO-160D, 15, Category Z	<p>The deflection of a free magnet in a uniform magnetic field having a horizontal intensity of 14.4 A/m ±10% when the test specimen is positioned on the east-west line through the pivot of the magnet shall be less than 0.3 meter.</p>
Induced Signal Susceptibility	RTCA/DO-160D, 19, Category Z	<p>Legends function when subjected to the 400Hz field of this test. Slight flickering or fluctuation of the legend brightness is acceptable provided the flicker would not confuse or distract a flight crew. The cap must automatically recover upon removal of the applied field and continue to function properly.</p>
Radio Frequency Susceptibility	RTCA/DO-160D, 20, Category T	<p>The legends shall function when subjected to injected fields from 10KHz to 400 MHz. Slight flickering or fluctuation of the legend brightness is acceptable provided the flicker would not confuse or distract a flight crew. The cap must automatically recover upon removal of the applied field and continue to function properly.</p>

389 Qualification Summary		
Test Name	Specification	Summary
Radio Frequency Emission	RTCA/DO-160D, 21, Category M	The LED circuit shall not generate interference exceeding the category M limits.
Lightning Induced Transient	RTCA/DO-160D, 22, Category XXC3	Cable bundle (unshielded) test. The legends shall function when subjected to the pulses. Slight flickering or fluctuation of the legend brightness is acceptable provided the flicker would not confuse or distract a flight crew. The cap must automatically recover upon removal of the applied field and continue to function properly.
Temperature - Altitude	MIL-STD-810C, Method 504.1, Category 1	The samples shall not visually deteriorate under the test conditions. When required for the step, the samples shall illuminate and cycle normally following varying temperature and altitude cycling.
Field of View	MIL-PRF-2 2885F, 4.7.39	The test specimen is viewed under a 45-degree template. The legend shall be easily recognized as being illuminated from a distance of 3 feet. The legend shall not be restricted or obscured, and all characters, symbols, and markings shall remain visible.
Stray Light	MIL-PRF-22885F, 4.7.38	With the illuminated surface of the cap covered by an opaque surface, the test specimen is inspected for stray light emitting from the cap. Any stray light shall not exceed 0.20 foot-Lamberts in any direction.

Reliability

The Chromalux 389 has an MTBF 1.5 million hours, which varies by configuration and application. The 1.5 million hour MTBF is for a standard, full display assuming a 20° C ambient operating temperature and 3000 flying hours per year. This prediction was performed using 217 Plus from RiAC software.

Installation

Tools Required

- Cap Extraction Tool: 29082-001
- 5-Pin Connector (25687-XXX) Removal Tool: 29082-002
- 6-Pin Connector (19854-XXX) Removal Tool: 29082-003
- Connector (28196-XXX) Removal Tool: M22885/108T8234
- Crimping Tool: M22520/7-01 and Positioner Tool: M22520/7-20 used to crimp Socket P/N M39029/22-192 to a 20, 22, or 24 gage wire
- Socket Installation and Removal Tool: M81969/14-10

Recommended Mounting Panel Cutouts

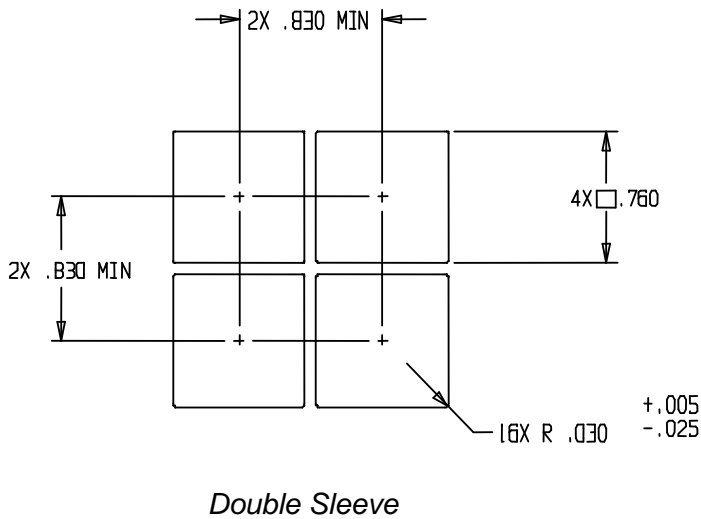
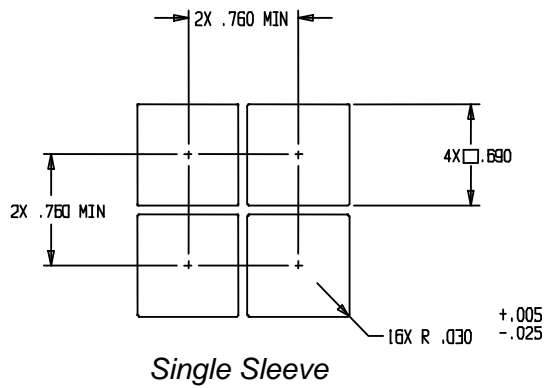

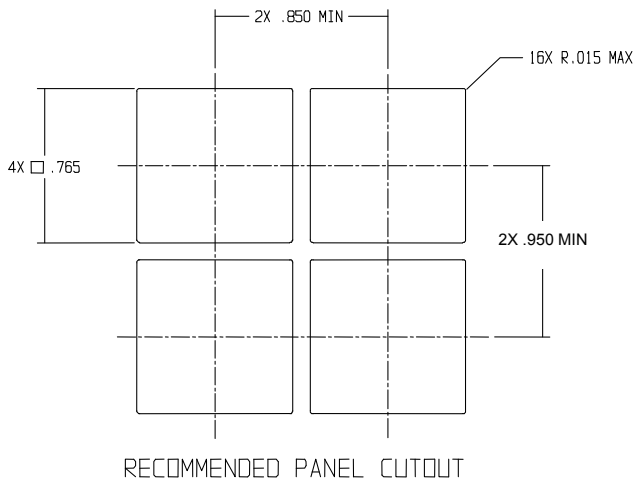
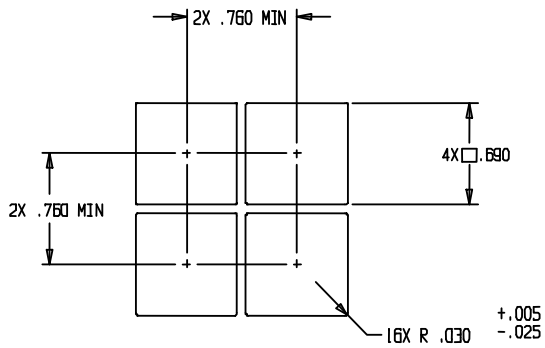
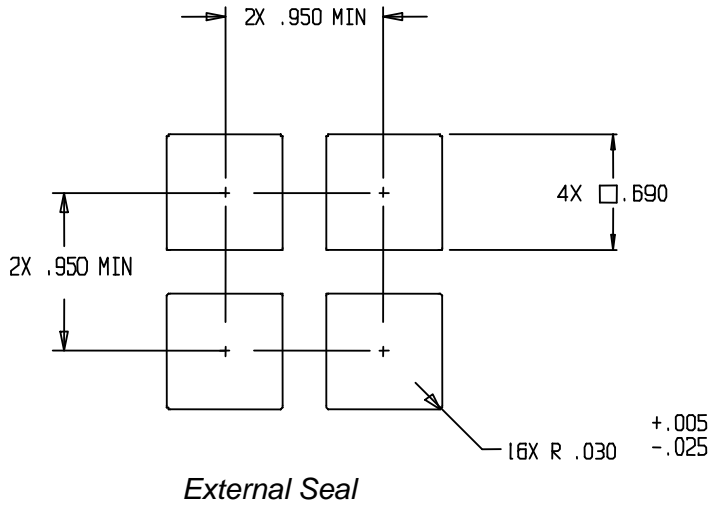

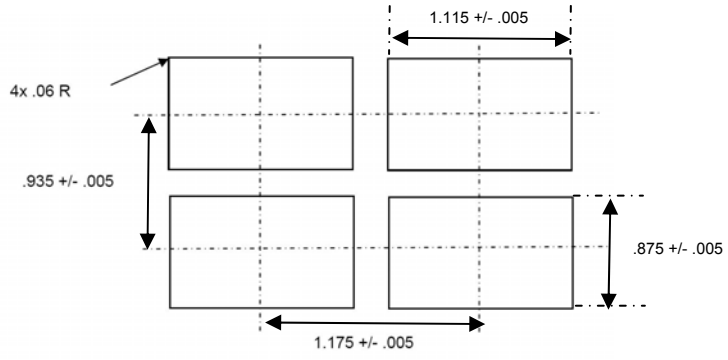

1380

Single-Sleeve Installation Procedure

This procedure applies to single-sleeve units and requires access to the back of the mounting panel. Once a single-sleeve unit is installed, any future replacement of the switch will also require access to the back of the mounting panel. If the capability to remove a pushbutton switch without having access to the back of the mounting panel is required, double-sleeve mounting or mounting with floating nut brackets and mounting screws should be used. Single-sleeve units are available with printed-wiring-board or solder-less connector module termination. The connector module can be configured to accept either M39029/57-354 or M39020/22-192 crimp sockets. A single-sleeve assembly comprises a pushbutton switch, spacer, mounting sleeve, and a connector module, if specified. The spacer is used to set the height of the cap assembly above the mounting panel. Single-sleeve mounting offers smaller center-to-center spacing of adjacent pushbuttons than double-sleeve mounting.

CAUTION: Disconnect all lighting and operating power to a panel before working on any switches in that panel.

- **The display circuits may be active even if displays are not illuminated. Unless lighting power is first disconnected, probing with metal tools may cause a short circuit.**
- **Switch actuation may activate a system and damage equipment or injure personnel.**

1. Grasp the cap with thumb and forefinger and pull it straight out from the base. The Chromalux 389 requires approximately 2-5 pounds of force to remove the cap from the base. The cap is permanently attached to the base with a flex circuit.

CAUTION: Do not crease flex circuit.

2. Rotate the cap to the side of the base opening. Two mounting-screw heads will be visible.

3. Rotate both mounting screws counterclockwise to move the mounting cams to the bottom of the mounting screws and into the recessed area.

4. Slide the base through the spacer if used.

5. Orient the pushbutton switch so that TOP is in the correct position, then insert it into the panel cutout and seat the spacer or mounting flange against the panel.

6. Orient the mounting sleeve so that TOP is in the correct position and slide it over the pushbutton switch from the back of the mounting panel. Make sure the mounting cams are visible through the mounting sleeve cutouts.

7. From the front of the mounting panel, rotate the mounting screws clockwise to draw up the mounting cams and capture the mounting sleeve. Torque each mounting screw to 16-20 inch-ounces. Do not over-tighten.

8. Wire the switch as required. If using a pushbutton switch with a connector module, it can be wired before installing the switch. The connector module can then be snapped

into the rear of the mounting sleeve. The connector module accepts the applicable M39029 crimp socket. Use the insertion/removal tool specific to your application.

9. Rotate the cap back into position and insert it into the base, pressing firmly until it seats with a snap. Cycle the pushbutton a few times to ensure smooth actuation.

10. Perform applicable functional procedures.

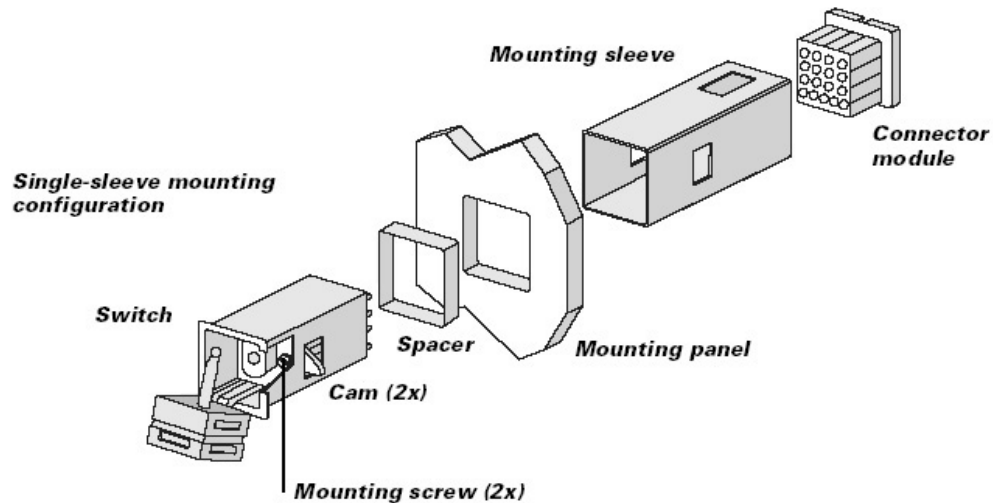

Double-Sleeve Installation Procedure

This procedure applies to double-sleeve units and requires access to the back of the mounting panel for initial installation. Once installed, a double-sleeve unit is a line-replaceable unit (LRU), so any future replacement of the switch is performed from the front of the mounting panel without affecting any wiring or termination. Double-sleeve units are available with printed-wiring-board or solder-less connector module termination. The connector module can be configured to accept either M39029/57-354 or M39020/22-192 crimp sockets. A double-sleeve assembly comprises a pushbutton switch, inner mounting sleeve, outer mounting sleeve, spacer, and a connector panel. The spacer is used to set the height of the cap assembly above the mounting panel.

CAUTION: Disconnect all lighting and operating power to a panel before working on any switches in that panel.

- **The display circuits may be active even if displays are not illuminated. Unless lighting power is first disconnected, probing with metal tools may cause a short circuit.**
- **Switch actuation may activate a system and damage equipment or injure personnel.**

1. Grasp the cap with thumb and forefinger and pull it straight out from the base. The Chromalux 389 requires approximately 2-5 pounds of force to remove the cap from the base. The cap is permanently attached to the base with a flex circuit.

CAUTION: Do not crease flex circuit.

2. Rotate the cap to the side of the base opening. Two mounting-screw heads will be visible.
3. Rotate both mounting screws counterclockwise to move the mounting cams to the bottom of the mounting screws and into the recessed area.
4. Slide the inner mounting sleeve through the spacer. Orient the inner mounting sleeve and spacer so that TOP is in the correct position. Insert the inner mounting sleeve spacer into the panel cutout seating the spacer against the mounting panel.
5. Orient the outer mounting sleeve so that TOP is in the correct position and the locking tab is mated with the cutout on the inner mounting sleeve. Slide the outer mounting sleeve over the inner mounting sleeve from the back of the panel. The locking tab on the outer sleeve will engage with the mating cutout on the inner sleeve prior to the outer sleeve touching the back of the mounting panel.
6. Orient the pushbutton switch so that TOP is in the correct position and insert it into the inner mounting sleeve. Verify the mounting cams are visible through the cutouts in both mounting sleeves.
7. From the front of the mounting panel, rotate the mounting screws clockwise to draw up the mounting cams and capture the mounting sleeve. Torque each mounting screw to 16-20 inch-ounces. Do not over tighten.
8. Wire the switch as required. If using a pushbutton switch with a connector module, it can be wired before installing the switch. The connector module can then be snapped into the rear of the mounting sleeve. The connector module accepts the applicable M39029 crimp socket. Use the insertion/removal tool specific to your application.
9. Rotate the cap back into position and insert it into the base, pressing firmly until it seats with a snap. Cycle the pushbutton a few times to ensure smooth actuation.
10. Perform applicable functional procedures.

389 Product Order Form

Email completed form to Carrie Anderson at carrie.anderson@esterline.com or by fax to (425) 297-9870.

Termination Type

- Poke-home connector (.040 dia. – 5 pin)
Accepts M39029/22-192 crimp pins
- Poke-home connector (.030 dia. – 6 pin) Accepts
M39029/57-354 crimp pins
- Header with PC type terminals

Mounting Style

- Universal sleeve (For 5 pin only)
- Single sleeve with connector module
- Double sleeve with connector module (not available
for external seal configuration)

Mounting-panel thickness

Specify thickness: _____

Switch action

- Alternate
- Momentary
- Indicator

Cap type

- Standard cap (.640 inch)
- 0.740 inch mushroom cap
- 0.812 inch mushroom cap
- Cap with External seal (.860 inch)
- Rectangular Cap (380 series)

Connector Module

- Included with switch assembly (standard)
- To be purchased separately

Input Voltage

- 28 VDC (standard)
- Other: _____

Dimming control Interface

- No dimming control required
- Discrete voltage inputs (Bright/Dim)
- PWM with varying duty cycle
- Constant current regulation
- Custom dimming (noted) _____

Other Options

Crimp Pins

- Not furnished with assembly (standard)
- To be included with switch assembly (at additional
cost)

Spacer

- Spacer height: _____
(.140" + Spacer = cap height above panel, only for
standard cap)

Flip Guard Assembly

- To be purchased separately
- To be included with switch assembly

Lens Configuration (circle one)

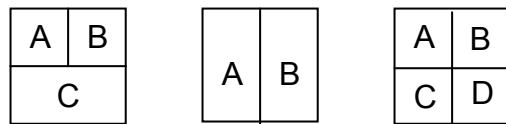
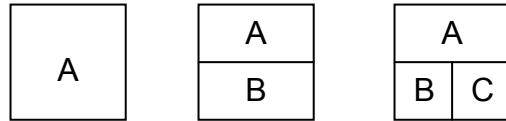

*

*

* Requires installation of switch in rotated position.

Legend Nomenclature

A _____ B _____ C _____ D _____

Legend type (others available on request)

- | | | | | |
|--------------------------|--------------------------|--------------------------|--------------------------|--|
| <input type="checkbox"/> | <input type="checkbox"/> | <input type="checkbox"/> | <input type="checkbox"/> | S (1B) (Sunlight readable, hidden legend – lighted characters) |
| <input type="checkbox"/> | <input type="checkbox"/> | <input type="checkbox"/> | <input type="checkbox"/> | B (1C) (Black characters, hidden legend – lighted background) |
| <input type="checkbox"/> | <input type="checkbox"/> | <input type="checkbox"/> | <input type="checkbox"/> | W (2D) (White background, black characters – lighted background) |
| <input type="checkbox"/> | <input type="checkbox"/> | <input type="checkbox"/> | <input type="checkbox"/> | N (2G2) (White letters, black background– lighted characters) |
| <input type="checkbox"/> | <input type="checkbox"/> | <input type="checkbox"/> | <input type="checkbox"/> | C (2B) (Colored background, black characters – lighted background) |
| <input type="checkbox"/> | <input type="checkbox"/> | <input type="checkbox"/> | <input type="checkbox"/> | (N LIGHT) (Lighted Letters) |
| <input type="checkbox"/> | <input type="checkbox"/> | <input type="checkbox"/> | <input type="checkbox"/> | (Custom Legend Noted) |

Font (others available on request)

- | | | | | |
|--------------------------|--------------------------|--------------------------|--------------------------|-------------------------------|
| <input type="checkbox"/> | <input type="checkbox"/> | <input type="checkbox"/> | <input type="checkbox"/> | Gorton Normal Gothic |
| <input type="checkbox"/> | <input type="checkbox"/> | <input type="checkbox"/> | <input type="checkbox"/> | Gorton Condensed Gothic |
| <input type="checkbox"/> | <input type="checkbox"/> | <input type="checkbox"/> | <input type="checkbox"/> | Gorton Extra Condensed Gothic |
| <input type="checkbox"/> | <input type="checkbox"/> | <input type="checkbox"/> | <input type="checkbox"/> | Futura Medium |
| <input type="checkbox"/> | <input type="checkbox"/> | <input type="checkbox"/> | <input type="checkbox"/> | Futura Medium Condensed |
| <input type="checkbox"/> | <input type="checkbox"/> | <input type="checkbox"/> | <input type="checkbox"/> | Best fit by KORRY |
| <input type="checkbox"/> | <input type="checkbox"/> | <input type="checkbox"/> | <input type="checkbox"/> | Other (Noted) _____ |

- | | | | | | | | | | |
|--------------------------|--------------------------|--------------------------|--------------------------|-------------------------|--------------------------|--------------------------|--------------------------|--------------------------|--------------------|
| A | B | C | D | Character Height | A | B | C | D | NVIS Colors |
| <input type="checkbox"/> | <input type="checkbox"/> | <input type="checkbox"/> | <input type="checkbox"/> | 0.156 inch | <input type="checkbox"/> | <input type="checkbox"/> | <input type="checkbox"/> | <input type="checkbox"/> | NVIS Green A |
| <input type="checkbox"/> | <input type="checkbox"/> | <input type="checkbox"/> | <input type="checkbox"/> | 0.125 inch | <input type="checkbox"/> | <input type="checkbox"/> | <input type="checkbox"/> | <input type="checkbox"/> | NVIS Green B |
| <input type="checkbox"/> | <input type="checkbox"/> | <input type="checkbox"/> | <input type="checkbox"/> | 0.109 inch | <input type="checkbox"/> | <input type="checkbox"/> | <input type="checkbox"/> | <input type="checkbox"/> | NVIS Yellow |
| <input type="checkbox"/> | <input type="checkbox"/> | <input type="checkbox"/> | <input type="checkbox"/> | 0.090 inch | <input type="checkbox"/> | <input type="checkbox"/> | <input type="checkbox"/> | <input type="checkbox"/> | NVIS Red |
| <input type="checkbox"/> | <input type="checkbox"/> | <input type="checkbox"/> | <input type="checkbox"/> | 0.072 inch | <input type="checkbox"/> | <input type="checkbox"/> | <input type="checkbox"/> | <input type="checkbox"/> | NVIS White |
| <input type="checkbox"/> | <input type="checkbox"/> | <input type="checkbox"/> | <input type="checkbox"/> | Best fit by KORRY | | | | | |

- | | | | | | | | | | |
|--------------------------|--------------------------|--------------------------|--------------------------|--------------|--------------------------|--------------------------|--------------------------|--------------------------|----------------------------|
| A | B | C | D | Color | A | B | C | D | NVIS Type and Class |
| <input type="checkbox"/> | <input type="checkbox"/> | <input type="checkbox"/> | <input type="checkbox"/> | Red | <input type="checkbox"/> | <input type="checkbox"/> | <input type="checkbox"/> | <input type="checkbox"/> | Type I Class A |
| <input type="checkbox"/> | <input type="checkbox"/> | <input type="checkbox"/> | <input type="checkbox"/> | Blue | <input type="checkbox"/> | <input type="checkbox"/> | <input type="checkbox"/> | <input type="checkbox"/> | Type II Class A |
| <input type="checkbox"/> | <input type="checkbox"/> | <input type="checkbox"/> | <input type="checkbox"/> | Amber | <input type="checkbox"/> | <input type="checkbox"/> | <input type="checkbox"/> | <input type="checkbox"/> | Type I Class B |
| <input type="checkbox"/> | <input type="checkbox"/> | <input type="checkbox"/> | <input type="checkbox"/> | White | <input type="checkbox"/> | <input type="checkbox"/> | <input type="checkbox"/> | <input type="checkbox"/> | Type II Class B |
| <input type="checkbox"/> | <input type="checkbox"/> | <input type="checkbox"/> | <input type="checkbox"/> | Green | <input type="checkbox"/> | <input type="checkbox"/> | <input type="checkbox"/> | <input type="checkbox"/> | Type I/II Class A |
| | | | | | <input type="checkbox"/> | <input type="checkbox"/> | <input type="checkbox"/> | <input type="checkbox"/> | Type I/II Class B |

KORRY COMPLETE ASSEMBLY PART NO.	
CHROMALUX SERIES	CHROMALUX 389 - INTEGRATED LED
CUSTOMER PART NO.	
TERMINATION TYPE	TBD
MOUNTING STYLE	TBD
MOUNTING PANEL THICKNESS (REF.)	TBD
SWITCH ACTION TYPE	TBD
SWITCH CONTACT RATING (MAX)	8 AMP RESISTIVE LOAD @ 28 VDC
LED CIRCUIT TYPE	TBD
CAP TYPE	TBD
LENS CONFIGURATION	TBD
INPUT VOLTAGE (ENTER IF OTHER THAN 28VDC)	28 VDC (STANDARD)
DIMMING CONTROL INTERFACE	TBD

REVISIONS			
LETTER	DESCRIPTION	DATE	APPROVAL

OPTIONAL COMPONENTS	INFORMATION
CRIMP PINS	NOT FURNISHED WITH UNIT
SPACER	NO HEIGHT:
FLIP GUARD	NO
CONNECTOR MODULE	INCLUDED WITH SW ASSY (STNDRD)

"TOP" location (▽)

LENS CONFIGURATION 1

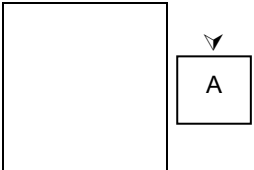

LENS CONFIGURATION 2

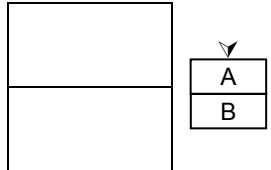

LENS CONFIGURATION 3

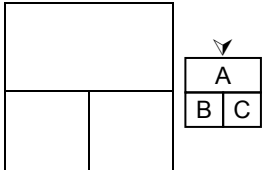

LENS CONFIGURATION 4

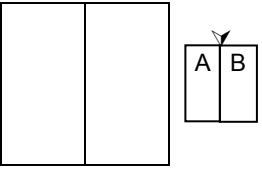

LENS CONFIGURATION 5

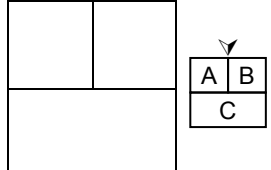

LENS CONFIGURATION 6

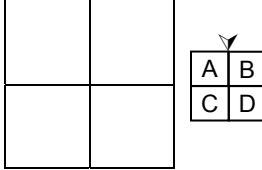

OTHER DISPLAY CHARACTERISTICS					
SEG-MENT	LEGEND TYPE	FONT TYPE	FONT HEIGHT	ILLUMINATED COLOR	NVIS TYPE & CLASS
A	TBD	TBD	---	TBD	TBD
B	---	---	---	---	TBD
C	---	---	---	---	TBD

NOTE: To determine COMPLETE configuration REFER TO CORRESPONDING KORRY drawing 389XX
 ADDITIONAL NOTES

Glossary

Actuation Force: Actuation force is defined as the highest force necessary to move the cap from its resting, off position, to the point of switch contact transfer, to actuate the switch.

Actuation Travel: Total travel of the cap assembly is the distance between the unlatched cap height and the position of the cap while fully depressed under a load of 5 pounds.

Alternate Actuation: Subminiature switch state changes when the cap is fully pressed. Subminiature state stays at new state when cap is released. Subminiature state changes back to original state when cap is fully pressed again and released.

Bi-Polarity Circuitry: KORRY incorporates a special feature in the switch lamp contacts that allows the installation power and ground (common) to be interchanged. The circuitry feature allows the installer to apply power or ground to either of the two contacts that illuminate a section of the cap assembly.

Cap Extraction Force: The force necessary to remove the cap assembly from the base assembly.

Contact Bounce: Rebounding of moving contact against stationary contact during transfer.

Contact Resistance: Resistance between the contacts (generally about 25 milliohms).

Drip Proof: A drip proof switch is one that has a cap seal that will prevent dripping water from penetrating the switch.

Electrical Life: MIL-PRF-8805 yields 50,000 cycles at rated load.

Gold Contacts: Gold plated contacts for current below 1 amp.

Inductive Load: Power distribution circuit.

Latched Cap Height: Latched cap height is the distance from the underside of the flange at the top of the switch base (equivalent to the mounting surface) to the top rim of the cap, when the cap is latched in its actuated position. Applies only to alternate actuation switch.

Make-Before-Break: The moving contacts of a double throw switch interrupt one circuit before completing another.

Moisture Proof: A moisture proof switch is one that will withstand high humidity and limited exterior environment such as rain.

Momentary Actuation: Subminiature switch state changes when the cap is fully pressed. Subminiature state returns to original state when cap is released.

Over-Travel: The distance the cap assembly travels to end of cap assembly travel.

Pre-Travel: The distance the cap assembly travels from free position to subminiature state transfer point.

Resistive Load: Loads that result in resistive heating of an element.

Silver Contacts: Silver-plated contacts for currents above 1 amp, generally up to 7 amps.

Splash Proof: A splash proof switch is one that will withstand a heavy rain stream of water.

Subminiature Switch Types (MIL-PRF-8805/109)

SPDT (Form C): Single Pole Double Throw Switch: Pushbutton switches will contain 1 to 4 of the subminiature switch type shown. Indicators do not contain a subminiature switch.

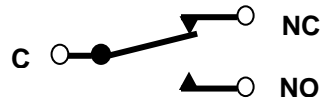

Tactile Response: The switch feature that indicates when the subminiature switch state change has taken place.

Touch Temperature: The stabilized temperature of the legend after the lamps have been energized.

Unlatched Cap Height: Unlatched cap height is the distance from the underside of the flange at the top of the switch base (equivalent to the mounting surface) to the top rim of the cap, when the cap is resting on its un-actuated position.

For more information about KORRY 389 switches or other control products:

425-297-9700

korry.sales@esterline.com

www.esterline.com/controlsystems

11910 Beverly Park Road
Everett, WA 98204
Tel: 425-297-9700
Email: korry.sales@esterline.com

