

Bulletin 801: Clamp, Flat Cable Restraint

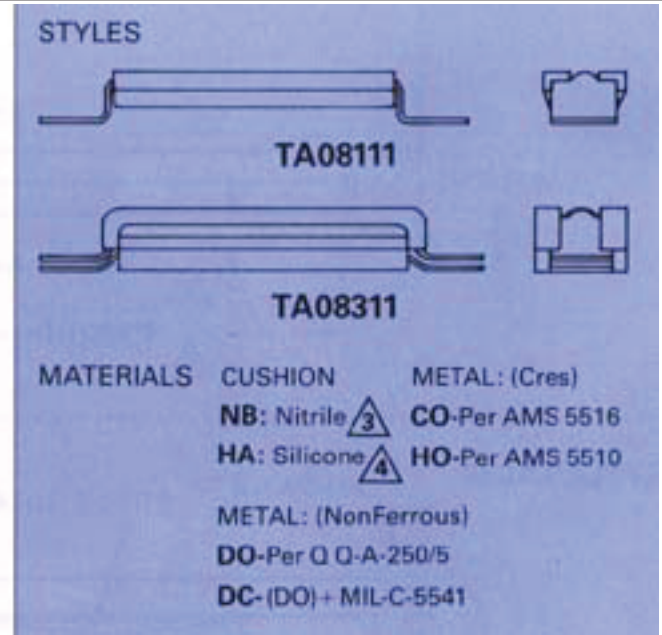

Part Numbering System

ex: TA08311CO0248HA = Flat cable clamp, double mounting with base bar, stainless steel bands with silicone cushion for 3" wide flat cable.

Breakdown:

Part number shown below is separated for clarity. When ordering, do not show spaces.

TA08311 CO 02 48 HA

- TA08311 = Basic Part Number
- CO = Metal (From Above)
- 02 = "A" Dimension – Height*: -01 (0 to 1/8), -02 (1/8 to 1/4)
- 48 = "B" Dimension – Width*: -16, -32, -48
- HA = Cushion (From Above)

* For optional "A" & "B" dimensions, consult TA Engineering department

Packaging note:

Item TA8111 will be bulk packed.

DIMENSIONS

STYLE TA081

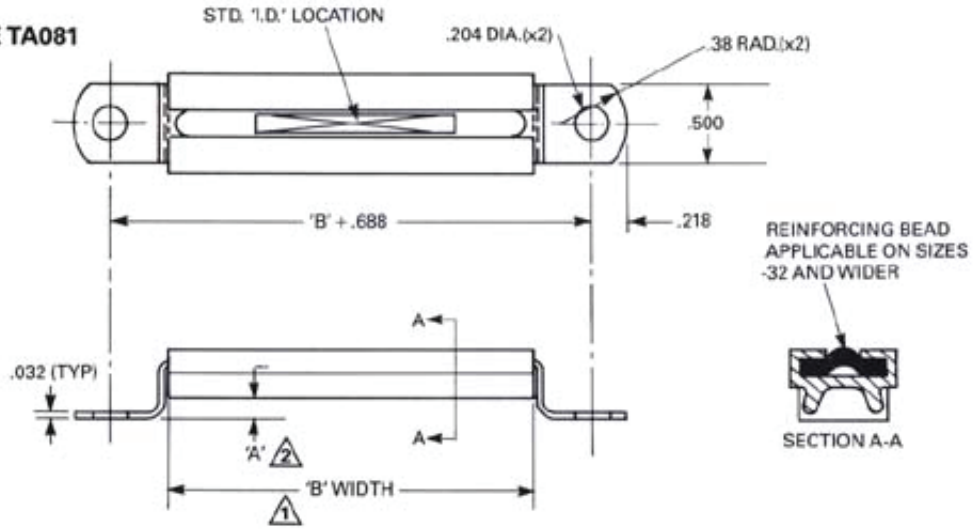

STYLE TA083

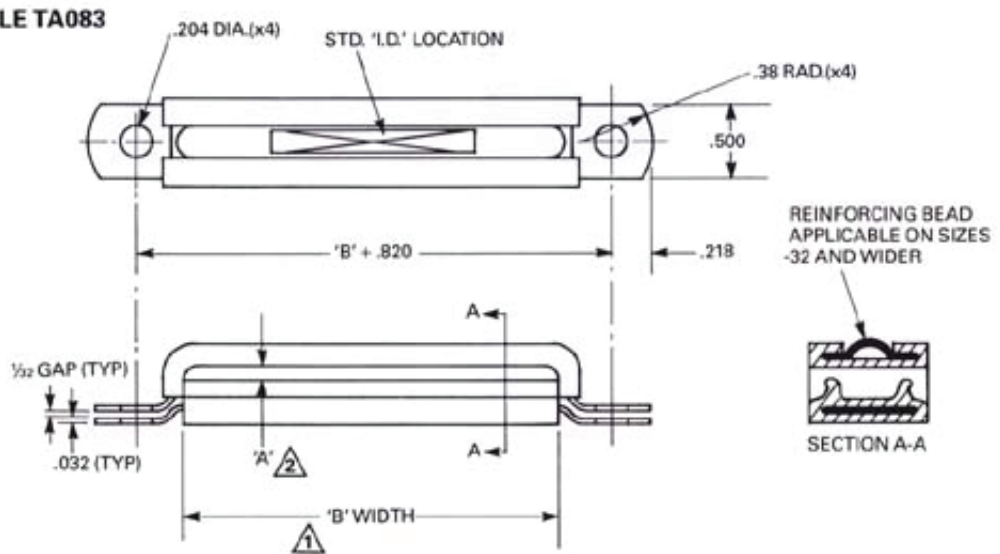

Notes:

- 1 Dimension "B" width in 1/16" increments i.e. -16(1"), -32(2"), -48(3"), etc.
- 2 Stacking heights variable with lengths of mounting screws
- 3 Self extinguishing material per UL94V-0 & FAA 25,853 (App F).Color – Yellow
- 4 Temperature range -65° to +400°F. Color – White

This document is the property of Kirkhill-TA and is conveyed with the express condition that it and the information contained in it are not to be used, disclosed or reproduced in whole or in part, for any purpose without the express written consent of Kirkhill-TA; and that no right is granted to disclose or so use any information contained in said document. These restrictions do not apply to vendor proprietary parts.