



Control &  
Communication Systems

### Korry® WXR Controller

Return-to-service test-equipment set for the Honeywell RDR-4000 weather radar (WXR) controller

## Complete test-equipment set now available for the Korry RDR-4000 WXR Controller



Esterline supports Honeywell's RDR-4000 Weather Radar System with a number of Korry WXR control-panel configurations. We are now making available to the airlines the complete test-equipment set as part of the WXR Controller Component Maintenance Manual (CMM). Our test equipment supports the products and CMMs shown in Table 1.

**Table 1 - RDR-4000 WXR Controller Support Documentation**

Honeywell document number	Document description
930-5101-001	Control Panel (CP-1A)
930-5102-001	Control Panel (CP-1A)
930-6101-001	Control Panel (CP-1B)
930-6201-001	Control Panel (CP-2B)
930-6201-002	Control Panel (CP-2B)
34-41-83	CMM CP-2B Controller
34-41-87	CMM CP-1A Controller
34-41-79	CMM CP-1B Controller

The test equipment includes the TVS Test Equipment and Functional Test Equipment shown in Figures 1 and 2 (back page). The complete set of equipment is shown in Table 2 (back page).

**Please contact us for availability and price at [korry.sales@esterline.com](mailto:korry.sales@esterline.com) or 425-297-9700.**

# Korry RDR-4000 WXR Controller Test Equipment

**Figure 1 - TVS Test-Equipment Setup**

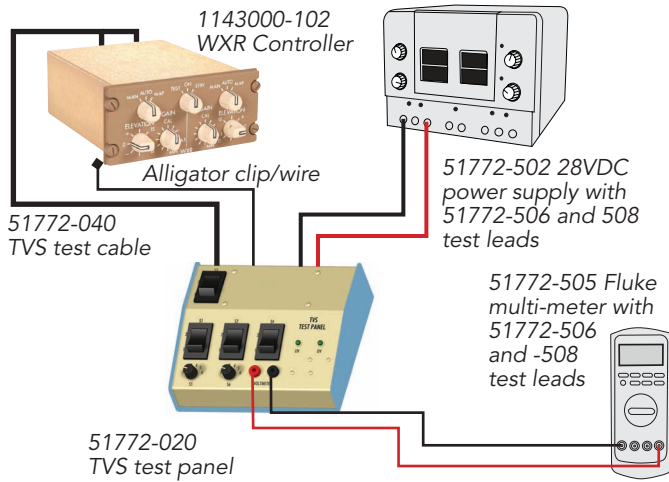

**Figure 2 - Functional Test-Equipment Setup**

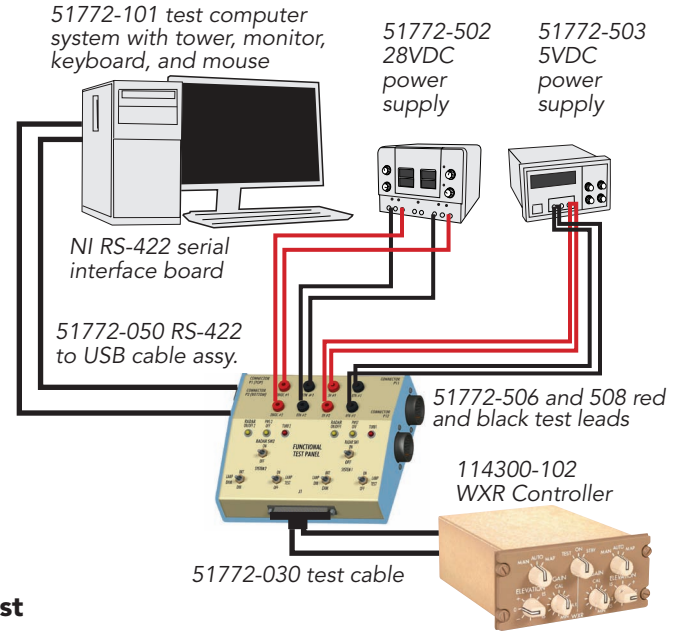

**Table 2 - RDR-4000 WXR Controller Test-Equipment List**

Part number	Description	Qty.	Manufacturer
51772-010	Functional test panel, RDR-4000	1	Esterline
51772-020	TVS test panel, RDR-4000	1	Esterline
51772-030	Functional test cable, RDR-4000	1	Esterline
51772-040	TVS test cable, RDR-4000	1	Esterline
51772-050	Dual serial cable, RDR-4000	1	Esterline
51772-070	Shipping container, 4.2 cu. ft.	2	Pelican, IM2975
51772-071	Shipping container, 6.0 cu. ft.	1	Pelican, 0370
51772-080	Misc. shroud component, RDR-4000	1	Esterline
P51772	Test software (P1143218-002)	1	Esterline
51772-101	Computer, monitor, keyboard, and mouse	1	OptiPlex 3020 mini tower; monitor: 17in. min. E1715S; keyboard: Dell KB212-B Quietkey; mouse: USB optical mouse MS111
51772-501	Kelvin probes assembly	1	Pomona
51772-502	BK Precision 1672 28VDC power supply	1	BK Precision
51772-503	BK Precision 1621A 5VDC power supply	1	BK Precision
51772-504	Micro-ohmmeter assembly	1	AMPTECH
51772-505	Fluke-87V/IMSK multi-meter	1	Fluke
51772-506	Red test lead assembly	4	Pomona
51772-507	6-in. digital calipers assembly	1	Mitutoyo
51772-508	Black test lead assembly	4	Pomona
51772-509	Plug set, supply conversion	1	Targus

For more information, please email us at [korry.sales@esterline.com](mailto:korry.sales@esterline.com) or call 425-297-9700.

Esterline  
11910 Beverly Park Road  
Everett, WA 98204  
425-297-9700  
[www.esterline.com](http://www.esterline.com)

**Esterline**  
Control & Communication Systems

Approved for public release; distribution is unlimited.

© 2016, Esterline Technology Corporation. "Korry" is a registered trademark of Esterline Technologies Corporation.