

MIL-PRF-6106 SOLENOID SERIES



Applications

- Aerospace
- Ground Vehicle
- Military
- Industrial

Features

- Compact Design
- High Reliability
- Gasket Sealed
- Fast Operate Time
- Low Contact Voltage Drop
- Hot-switch Life Tested

Benefits

- Max. Weight: 2.6 lbs
- Rated for 50,000 operations
- Helps Prevent FOD
- Max. Operate Time: 40 mS
- Max. Voltage Drop: 175 mV
- Make, Carry, & Break of Rated Load

Part Number Cross Reference & Mounting Styles

MIL SPEC PN	LEACH PN	BRACKET	FORM FACTOR / CURRENT
MS24187-D1	7064-423	BOTTOM	1P DT NO – 50/25 Amp
MS24187-D2	7064-424	BOTTOM	1P DT NO – 50/25 Amp
MS24166-D1	7064-4653	BOTTOM	1P ST NO – 50 Amp
MS24166-D2	7064-238	SIDE	1P ST NO – 50 Amp
MS24178-D1	7064-4656	BOTTOM	2 PST NO – 55 Amp
MS24171-D1	7264-4654	BOTTOM	1P ST NO – 200 Amp
MS24171-D2	7264-283	SIDE	1P ST NO – 200 Amp
MS24172-D1	7264-4655	BOTTOM	1P ST NO – 200 Amp
MS24172-D2	7264-332	SIDE	1P DT NO – 200 Amp
MS24185-D1	7401-4658	BOTTOM	1P ST NO – 400 Amp
MS24185-D2	7401-C	SIDE	1P ST NO – 400 Amp
MS24179-D1	7401-9444	BOTTOM	1P ST NO – 400 Amp
MS24179-D2	7401-1	SIDE	1P ST NO – 400 Amp

* 7064-423 and 7064-424 differentiated by mechanical life rating

General Dimensions

7064 Series

STUD, THD .138-32 UNC-2A
 NUT, .138-32 UNC-2B, CORROSION RESISTANT
 SPRING WASHER, NO. 6, CORROSION RESISTANT
 FLAT WASHER, NO. 6, CORROSION RESISTANT
 2 EACH REQUIRED

STUD, THD .190-32 UNF-2A
 NUT, .190-32 UNF-2B, CORROSION RESISTANT
 SPRING WASHER, NO. 10, CORROSION RESISTANT
 FLAT WASHER, NO. 10, CORROSION RESISTANT
 4 EACH REQUIRED

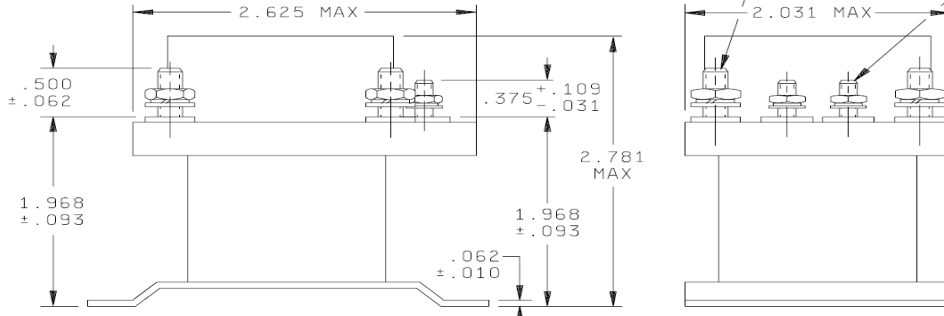

7264 Series

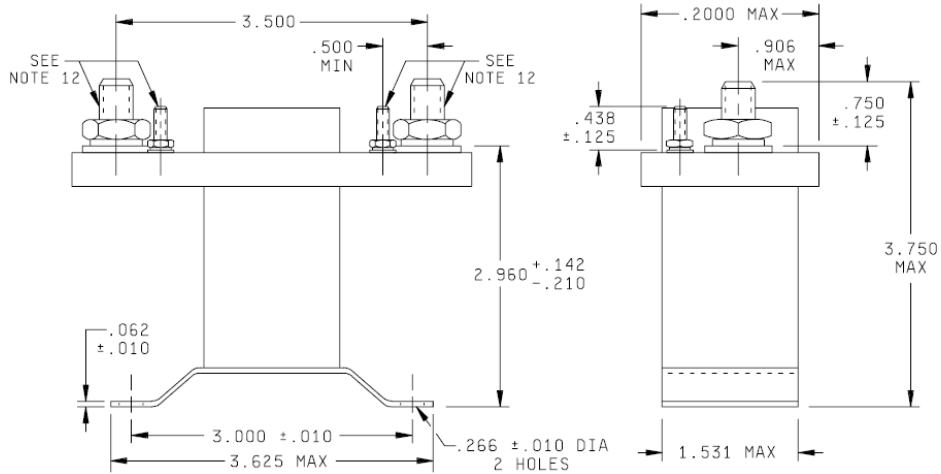

7401 Series

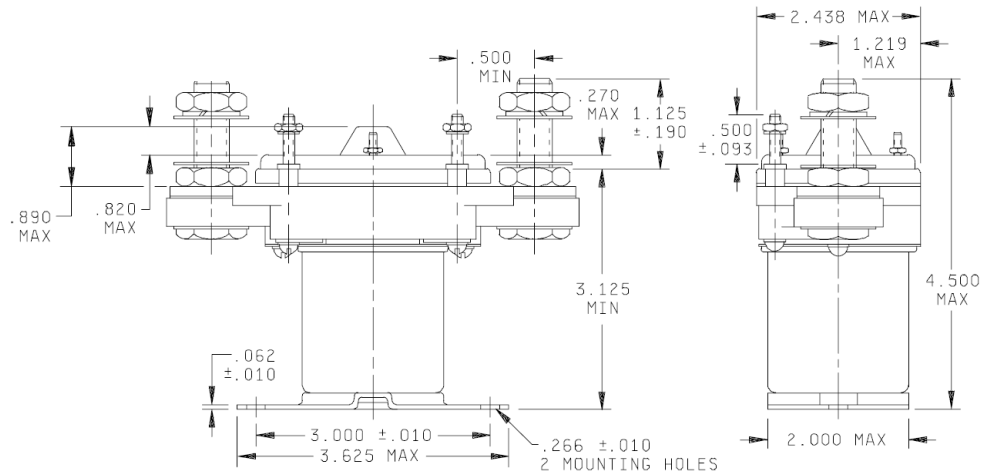

Worldwide Locations

North America

6900 Orangethorpe Avenue
 Buena Park, CA 90622-5032
 Phone: (714) 736-7599
www.esterline.com/powersystems

Asia-Pacific

Unit 602-603 6/F Lakeside 1
 No 8 Science Park West Avenue
 Phase Two Hong Kong Science Park
 Tai Po, N.T., Hong Kong
 Phone: (852) 2 191 3830

Europe

2 Rue Goethe
 F-57430 Sarralbe
 France
 Phone: (33) 3 87 97 98 97

Esterline
 Power Systems