

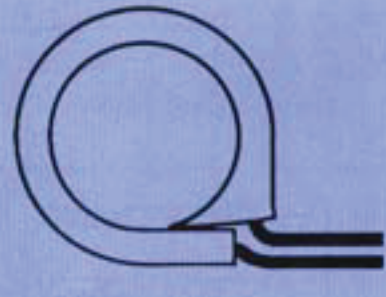

Bulletin 270 and 271: Clamp, Loop Style General Purpose

FAA TSO-C171

		<p>270</p> <p>TA027000 Cushioned Sizes -02 thru -66</p>
		<p>271</p> <p>TA027001 Insert Sizes -01 thru -05</p>

Part Numbering System

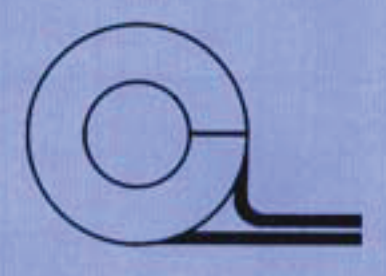
ex: TA027000HO_16HB = Loop style clamp with silicone "HB" cushion/wedge and stainless steel band for 1.00" diameter

Breakdown:

Part number shown below is separated for clarity. When ordering, do not show spaces.

TA027000 HO 16 HB

- TA027000 = Basic Part Number
- HO = Metal Material Code ⁴
- = Snap-Loc Foot/Code "L" or Foot Reinforcing Tab/Code "R" See Bulletin 130 (Omit if not required) ⁴
- 16 = "D" Diameter in 1/16" Increments
- HB = Elastomer Cushion Code ⁴

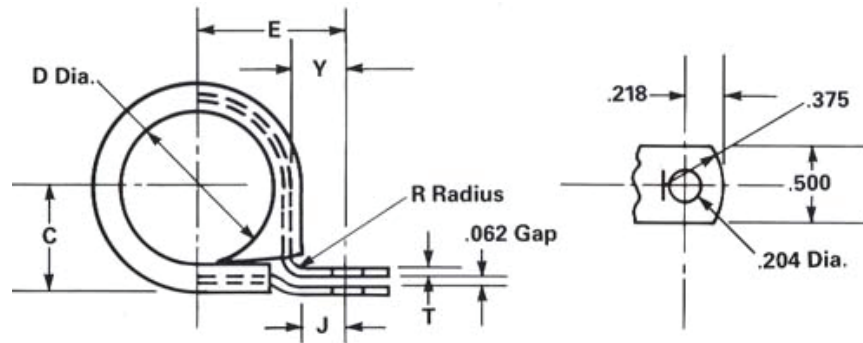
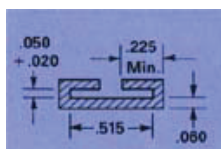

Diagram ID	▶	D	E	T		C	J	R	Y	Weight lbs. / 100 pcs.	
				Steel	Alum.					Steel	Alum.
	Cushioning Elastomer	Nom.	+/- .015	Steel	Alum.	Ref.	Ref.	+/- .010	Ref.	Steel	Alum.
Part Number											
TA027000()02()	Cushion Only ^{1,2}	.125	.405 + D/2	.020	.030	.130 + D/2	.235	.090	.325	.95	.65
TA027000()03()	Cushion Only ^{1,2}	.188	.405 + D/2	.020	.030	.130 + D/2	.235	.090	.325	1.05	.75
TA027000()04()	Cushion Only ^{1,2}	.250	.405 + D/2	.020	.030	.130 + D/2	.235	.090	.325	1.15	.85
TA027000()05()	Cushion Only ^{1,2}	.312	.405 + D/2	.020	.030	.130 + D/2	.235	.090	.325	1.23	.93
TA027000()06()	Cushion + Full Contour Wedge M85052 Equiv. ^{1,2,3}	.375	.405 + D/2	.020	.030	.130 + D/2	.235	.090	.325	1.32	1.03
TA027000()07()	Cushion + Full Contour Wedge M85052 Equiv. ^{1,2,3}	.438	.405 + D/2	.020	.030	.130 + D/2	.235	.090	.325	1.43	1.13
TA027000()08()	Cushion + Full Contour Wedge M85052 Equiv. ^{1,2,3}	.500	.405 + D/2	.020	.030	.130 + D/2	.235	.090	.325	1.50	1.20
TA027000()09()	Cushion + Full Contour Wedge M85052 Equiv. ^{1,2,3}	.562	.460 + D/2	.030	.050	.140 + D/2	.256	.125	.368	2.30	2.00
TA027000()10()	Cushion + Full Contour Wedge M85052 Equiv. ^{1,2,3}	.625	.460 + D/2	.030	.050	.140 + D/2	.256	.125	.368	2.50	2.20
TA027000()11()	Cushion + Full Contour Wedge M85052 Equiv. ^{1,2,3}	.688	.460 + D/2	.030	.050	.140 + D/2	.256	.125	.368	2.65	2.35
TA027000()12()	Cushion + Full Contour Wedge M85052 Equiv. ^{1,2,3}	.750	.460 + D/2	.030	.050	.140 + D/2	.256	.125	.368	2.80	2.50
TA027000()13()	Cushion + Full Contour Wedge M85052 Equiv. ^{1,2,3}	.812	.460 + D/2	.030	.050	.140 + D/2	.256	.125	.368	2.91	2.61
TA027000()14()	Cushion + Full Contour Wedge M85052 Equiv. ^{1,2,3}	.875	.460 + D/2	.030	.050	.140 + D/2	.256	.125	.368	3.10	2.80
TA027000()15()	Cushion + Full Contour Wedge M85052 Equiv. ^{1,2,3}	.938	.460 + D/2	.030	.050	.140 + D/2	.256	.125	.368	3.30	3.00
TA027000()16()	Cushion + Full Contour Wedge M85052 Equiv. ^{1,2,3}	1.000	.460 + D/2	.030	.050	.140 + D/2	.256	.125	.368	3.50	3.20
TA027000()17()	Cushion + Full Contour Wedge M85052 Equiv. ^{1,2,3}	1.062	.470 + D/2	.040	.060	.150 + D/2	.262	.125	.370	3.80	3.50
TA027000()18()	Cushion + Full Contour Wedge M85052 Equiv. ^{1,2,3}	1.125	.470 + D/2	.040	.060	.150 + D/2	.262	.125	.370	4.20	3.90
TA027000()19()	Cushion + Full Contour Wedge M85052 Equiv. ^{1,2,3}	1.188	.470 + D/2	.040	.060	.150 + D/2	.262	.125	.370	4.35	4.05
TA027000()20()	Cushion + Full Contour Wedge M85052 Equiv. ^{1,2,3}	1.250	.470 + D/2	.040	.060	.150 + D/2	.262	.125	.370	4.50	4.20
TA027000()21()	Cushion + Full Contour Wedge M85052 Equiv. ^{1,2,3}	1.312	.470 + D/2	.040	.060	.150 + D/2	.262	.125	.370	4.65	4.35
TA027000()22()	Cushion + Full Contour Wedge M85052 Equiv. ^{1,2,3}	1.375	.470 + D/2	.040	.060	.150 + D/2	.262	.125	.370	4.80	4.50
TA027000()23()	Cushion + Full Contour Wedge M85052 Equiv. ^{1,2,3}	1.438	.470 + D/2	.040	.060	.150 + D/2	.262	.125	.370	4.95	4.65
TA027000()24()	Cushion + Full Contour Wedge M85052 Equiv. ^{1,2,3}	1.500	.470 + D/2	.040	.060	.150 + D/2	.262	.125	.370	5.10	4.80

Diagram ID	▶	D	E	T		C	J	R	Y	Weight	
				Steel	Alum.					lbs. / 100 pcs.	Steel
	Cushioning Elastomer	Nom.	+/- .015	Steel	Alum.	Ref.	Ref.	+/- .010	Ref.	Steel	Alum.
Part Number											
TA027000(J25(Cushion + Wedge ¹	1.562	.470 + D/2	.040	.060	.150 + D/2	.262	.125	.370	5.28	4.95
TA027000(J26(Cushion + Wedge ¹	1.625	.470 + D/2	.040	.060	.150 + D/2	.262	.125	.370	5.46	5.10
TA027000(J27(Cushion + Wedge ¹	1.688	.470 + D/2	.040	.060	.150 + D/2	.262	.125	.370	5.64	5.25
TA027000(J28(Cushion + Wedge ¹	1.750	.470 + D/2	.040	.060	.150 + D/2	.262	.125	.370	5.82	5.40
TA027000(J29(Cushion + Wedge ¹	1.812	.470 + D/2	.040	.060	.150 + D/2	.262	.125	.370	6.00	5.55
TA027000(J30(Cushion + Wedge ¹	1.875	.470 + D/2	.040	.060	.150 + D/2	.262	.125	.370	6.18	5.70
TA027000(J31(Cushion + Wedge ¹	1.938	.470 + D/2	.040	.060	.150 + D/2	.262	.125	.370	6.39	5.85
TA027000(J32(Cushion + Wedge ¹	2.000	.470 + D/2	.040	.060	.150 + D/2	.262	.125	.370	6.57	6.00
TA027000(J33(Cushion + Wedge ¹	2.062	.470 + D/2	.040	.060	.150 + D/2	.262	.125	.370	6.75	6.15
TA027000(J34(Cushion + Wedge ¹	2.125	.470 + D/2	.040	.060	.150 + D/2	.262	.125	.370	6.93	6.30
TA027000(J35(Cushion + Wedge ¹	2.188	.470 + D/2	.040	.060	.150 + D/2	.262	.125	.370	7.11	6.45
TA027000(J36(Cushion + Wedge ¹	2.250	.470 + D/2	.040	.060	.150 + D/2	.262	.125	.370	7.29	6.60
TA027000(J37(Cushion + Wedge ¹	2.312	.470 + D/2	.040	.060	.150 + D/2	.262	.125	.370	7.47	6.75
TA027000(J38(Cushion + Wedge ¹	2.375	.470 + D/2	.040	.060	.150 + D/2	.262	.125	.370	7.65	6.90
TA027000(J39(Cushion + Wedge ¹	2.438	.470 + D/2	.040	.060	.150 + D/2	.262	.125	.370	7.83	7.05
TA027000(J40(Cushion + Wedge ¹	2.500	.470 + D/2	.040	.060	.150 + D/2	.262	.125	.370	8.00	7.20
TA027000(J41(Cushion + Wedge ¹	2.562	.470 + D/2	.040	.060	.150 + D/2	.262	.125	.370	8.18	7.35
TA027000(J42(Cushion + Wedge ¹	2.625	.470 + D/2	.040	.060	.150 + D/2	.262	.125	.370	8.36	7.50
TA027000(J43(Cushion + Wedge ¹	2.688	.470 + D/2	.040	.060	.150 + D/2	.262	.125	.370	8.54	7.65
TA027000(J44(Cushion + Wedge ¹	2.750	.470 + D/2	.040	.060	.150 + D/2	.262	.125	.370	8.72	7.80
TA027000(J45(Cushion + Wedge ¹	2.812	.470 + D/2	.040	.060	.150 + D/2	.262	.125	.370	8.90	7.95
TA027000(J46(Cushion + Wedge ¹	2.875	.470 + D/2	.040	.060	.150 + D/2	.262	.125	.370	9.08	8.10
TA027000(J47(Cushion + Wedge ¹	2.938	.470 + D/2	.040	.060	.150 + D/2	.262	.125	.370	9.26	8.25
TA027000(J48(Cushion + Wedge ¹	3.000	.470 + D/2	.040	.060	.150 + D/2	.262	.125	.370	9.44	8.40
TA027000(J49(Cushion Only ¹	3.062	.480 + D/2	.050	.060	.160 + D/2	.262	.125	.370	12.50	8.55
TA027000(J50(Cushion Only ¹	3.125	.480 + D/2	.050	.060	.160 + D/2	.262	.125	.370	12.75	8.70
TA027000(J51(Cushion Only ¹	3.188	.480 + D/2	.050	.060	.160 + D/2	.262	.125	.370	13.00	8.85
TA027000(J52(Cushion Only ¹	3.250	.480 + D/2	.050	.060	.160 + D/2	.262	.125	.370	13.25	9.00
TA027000(J53(Cushion Only ¹	3.312	.480 + D/2	.050	.060	.160 + D/2	.262	.125	.370	13.50	9.15
TA027000(J54(Cushion Only ¹	3.375	.480 + D/2	.050	.060	.160 + D/2	.262	.125	.370	13.75	9.30
TA027000(J55(Cushion Only ¹	3.438	.480 + D/2	.050	.060	.160 + D/2	.262	.125	.370	14.00	9.45
TA027000(J56(Cushion Only ¹	3.500	.480 + D/2	.050	.060	.160 + D/2	.262	.125	.370	14.25	9.60
TA027000(J57(Cushion Only ¹	3.562	.480 + D/2	.050	.060	.160 + D/2	.262	.125	.370	14.50	9.75
TA027000(J58(Cushion Only ¹	3.625	.480 + D/2	.050	.060	.160 + D/2	.262	.125	.370	14.75	9.90
TA027000(J59(Cushion Only ¹	3.688	.480 + D/2	.050	.060	.160 + D/2	.262	.125	.370	15.00	10.05
TA027000(J60(Cushion Only ¹	3.750	.480 + D/2	.050	.060	.160 + D/2	.262	.125	.370	15.25	10.20
TA027000(J61(Cushion Only ¹	3.812	.480 + D/2	.050	.060	.160 + D/2	.262	.125	.370	15.50	10.35
TA027000(J62(Cushion Only ¹	3.875	.480 + D/2	.050	.060	.160 + D/2	.262	.125	.370	15.75	10.50
TA027000(J63(Cushion Only ¹	3.938	.480 + D/2	.050	.060	.160 + D/2	.262	.125	.370	16.00	10.65
TA027000(J64(Cushion Only ¹	4.000	.480 + D/2	.050	.060	.160 + D/2	.262	.125	.370	16.25	10.80
TA027000(J65(Cushion Only ¹	4.062	.480 + D/2	.050	.060	.160 + D/2	.262	.125	.370	16.50	10.95
TA027000(J66(Cushion Only ¹	4.125	.480 + D/2	.050	.060	.160 + D/2	.262	.125	.370	16.75	11.10

Notes



1 Cushion
Cushion (no wedge) on sizes -02 thru -05 and -49 thru -66. Cushion (with full contour wedge) on sizes -06 thru -24. -24 wedge size will be used on sizes -25 thru -48.



3 Snap-Loc Foot Option
(See Bulletin 130)
Dimensionally interchangeable with M85052, sizes -02 thru -24.

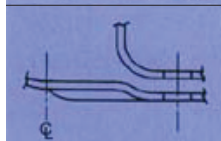

2 Stiffening Bead
Stiffening bead (full flowing on sizes -04 thru -24. -24 bead size will be used on sizes -25 thru -66.

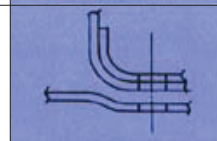

4 Reinforcing Foot Option
(See Bulletin 130)
All Materials may be selected from Bulletins 120 and Options from Bulletin 130.

ELASTOMER INSERT ALTERNATIVE TO BULLETIN 270 FOR SIZES -01 THRU -05 ONLY

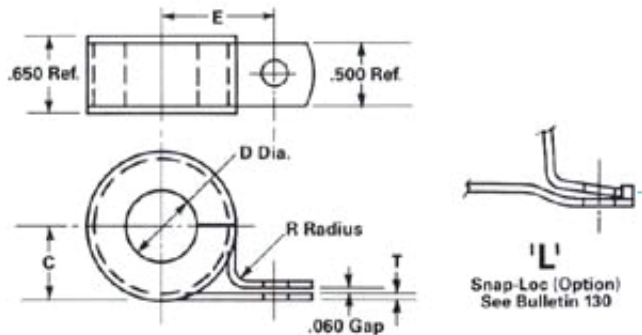

	Diagram ID ▶	D	E	T	T	C	R	Weight lbs. / 100 pcs.
		Nom.	+/- .015	Steel	Alum.	Ref.	+/- .010	Approx.
Part Number	Applicable Insert See Bulletin 130							
TA027001()01()	TA71100002()01	.062	.593	.020	.030	.250	.090	1.15
TA027001()02()	TA71100002()02	.125	.593	.020	.030	.250	.090	1.00
TA027001()03()	TA71100002()03	.188	.593	.020	.030	.250	.090	0.90
TA027001()04()	TA71100003()04	.250	.655	.020	.030	.310	.090	1.65
TA027001()05()	TA71100003()05	.312	.655	.020	.030	.310	.090	1.50

For sizes -06 thru -24, use Bulletin 270 (Previous pages)

Materials: Refer to Bulletin 120

Inserts: Refer to Bulletin 130

Part Numbering System

ex: **TA027001HO_04NB** = Loop style clamp with nitrile insert, stainless band for .250 diameter.

Breakdown:

Part number shown below is separated for clarity. When ordering, do not show spaces.

TA027001 HO 04 NB

TA027001 = Basic Part Number

HO = Metal Material Code ⁴

— = Snap-Loc Foot/Code "L". See Bulletin 130 (Omit if not required) ⁴

16 = "D" Diameter in 1/16" Increments

HB = Elastomer Cushion Code ⁴

© 2003 Kirkhill-TA Co.

This document is the property of Kirkhill-TA and is conveyed with the express condition that it and the information contained in it are not to be used, disclosed or reproduced in whole or in part, for any purpose without the express written consent of Kirkhill-TA; and that no right is granted to disclose or so use any information contained in said document. These restrictions do not apply to vendor proprietary parts.