

Bulletin 1400: Flip-Loc® Double Offset Mount Hinged

Mounting Bracket Fixed

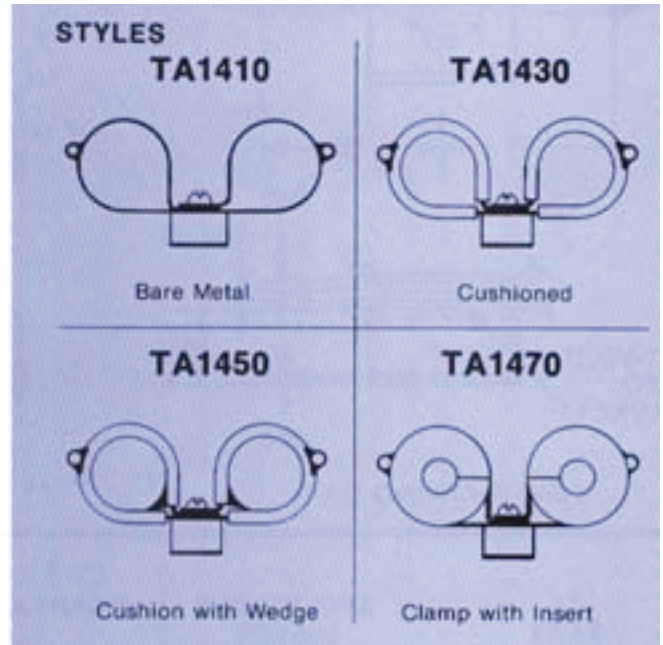
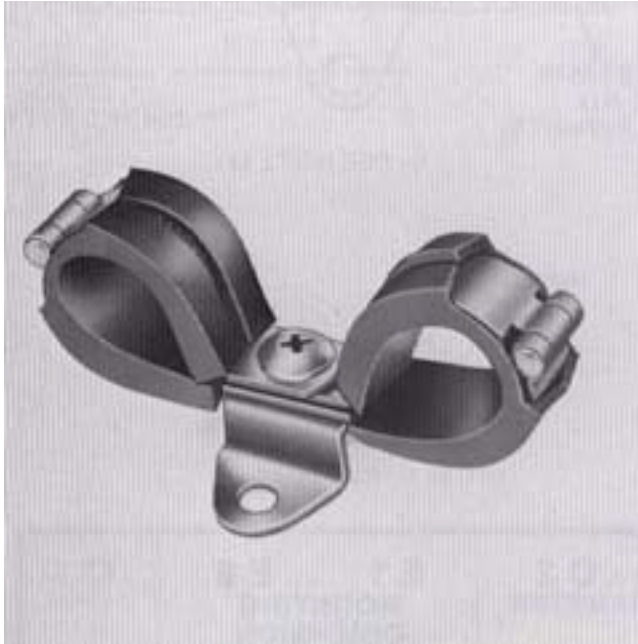

Part Numbering System

ex: TA1430--20HB2001 = Flip-Loc clamp double loop stainless steel x 1/2 wide band with 2 hole mounting bracket. Silicone (HB) cushion, slot head screw (1/4 turn lock), for tube size 1-1/4 diameter (both loops).

Breakdown:

Part number shown below is separated for clarity. When ordering, do not show spaces.

Note: By combining above styles, sizes of each loop can range from --01 to --32.
See below for Part Numbers and details of possible configurations.

TA1430 -- 20 HB 20 01

- TA1430 = Basic Part Number
- = Bracket as Shown (For options, see Bulletin 1000A)
- 20 = D1 Tube Diameter in 1/16" increments (Show as a minimum of 2 digits)
- HB = Cushion or Insert Material Code (See Bulletins 120 and 130)
- 20 = D2 Tube Diameter in 1/16" Increments (Show as a minimum of 2 digits)
- 01 = Screw Head Option (See Bulletin 1000A)

Specifications

DIMENSIONS

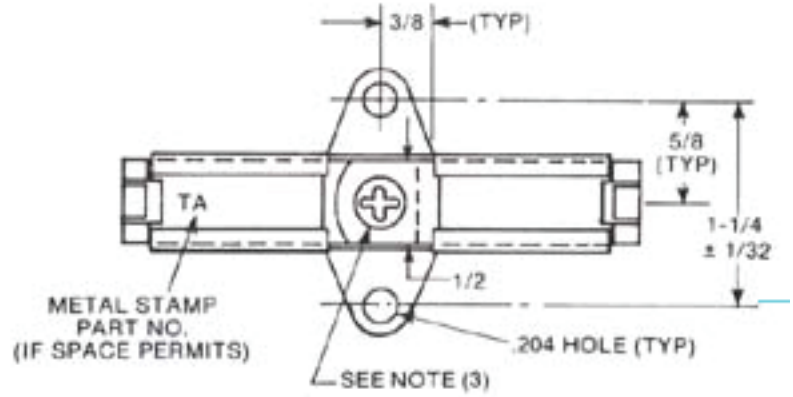
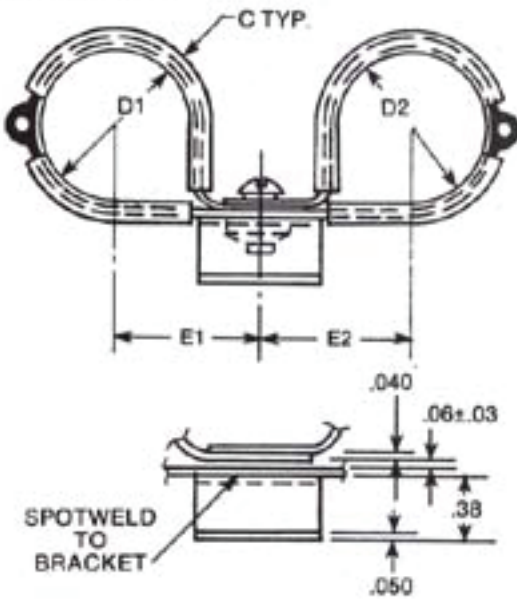

VIEW SHOWING GAP



Diagram ID	Applicable Insert See Note 1	Nominal Diameter Expressed in 1/16" increments		Mounting Dimensions		C
		D_1	D_2	E_1	E_2	
Tolerances				$\pm .015$		Ref.
Part Number						
TA1410-- ()--()	N/A	-08	-32	$C/2 + .461$		N/A
TA1430-- ()()()	N/A	-08	-32	$C/2 + .523$.210
TA1450-- ()()()	N/A	-08	-32	$C/2 + .523$.210
TA1470-- ()()()	TA71100003	-01	-05	.711		N/A
TA1471-- ()()()	TA71100004	-02	-07	.773		N/A
TA1472-- ()()()	TA71100003	-01 thru -05	No Wedge -08 thru -32 Wedge	.711	$D/2 + .523$	
TA1473-- ()()()	TA71100003	-01 thru -05	No Wedge -08 thru -32 Wedge	.711	$D/2 + .523$	
TA1474-- ()()()	TA71100004	-02 thru -07	No Wedge -08 thru -32 Wedge	.773	$D/2 + .523$	
TA1475-- ()()()	TA71100004	-02 thru -07	No Wedge -08 thru -32 Wedge	.773	$D/2 + .523$	

Material: Band and bracket: 321 stainless steel, annealed, per AMS 5510

Finish: Ball burnished and passivated per AMS 2700

Note 1: Synthetic rubber inserts are required and supplied when specifying style TA1470, TA1471, TA1472 for nominal diameters within the limits shown. Applicable insert part numbers are shown for reference only. See Bulletins 120 and 130 for insert configurations and materials available. "N/A" shown in this column indicates that standard cushion configurations and materials will be supplied as applicable for styles TA1430 and TA1450.

Note 2: Styles TA1472 thru TA1475 combines TA1430 or TA1450 with TA1470 or TA1471 providing a minimum and a maximum size per double clamp.

Note 3: Plastic inserts are an available option. Contact TA Product Engineering Dept.

Note 4: Screw head options, see Bulletin 1000A Screw size (not optional) per strap width, 10-32 screws are used on 1/2 wide strap clamps, 1/4-28 screws are used on larger widths.