

Bulletin 110: Clamp Installation Guide

While many engineers and mechanics consider a clamp, an insignificant piece of hardware, its correct selection and installation can mean the difference between a successful trouble free installation, and system failures involving high maintenance costs. In an attempt to aid in the effort to improve clamping techniques and logistics, we have developed a completely new line of clamps and materials described in this catalogue and the amending bulletins.

In the past, the majority of Rubber Insulation Materials were of one color, black. You will note from our Materials Selection Guide that all have now been color coded to insure that the correct clamp is installed in the correct environment. Also, as a result of complete material testing program, we can now safely recommend their service limitations. However, we recognize that we cannot answer all questions in a catalog, so we encourage you to consult with TA's Engineering Department on those unanswered questions, or our recommendations and comments on your clamp selection. Also, if any of the clamp styles do not fully meet your requirements, keep in mind we can and will engineer modified versions and new configurations.

To aid you in determining the best and most economical clamp for your needs, we are listing some of the questions which should be answered prior to selection of any systems installation hardware.

INFORMATION NECESSARY FOR SATISFACTORY CLAMP ENGINEERING

1. Item or system to be secured

a. Shape and size _____

2. Environment

a. Temperature: High _____ Low _____ Operating _____ Continuous _____

b. Fluids: Type of fluid _____ immersion _____ splash _____

c. Vibration and Shock: High _____ Low _____ Medium _____ None _____

d. Area of use: Interior _____ Exterior _____

3. Structural Considerations

a. Available mounting area and clearance _____

b. Position of mounting – inverted, horizontal, vertical _____

c. Possible external forces applicable (such as line surge and structure flex) _____

d. Size of stud or bolt used for mounting _____

e. Is there danger of abrasion or galling? _____

4. Installation Technique

a. Will the clamp be installed in the structure prior to placement of the tube or wire bundle? _____

b. Will the clamp be placed on the wiring or tube prior to installation on the structure? _____

c. Will the clamp and wiring or tube be installed simultaneously? _____

5. Cost

Will the item permit the use of the "All Problem Solver" or must the commercial approach be taken? _____

TUBE INSTALLATIONS

Fit

Selecting the correct size clamp for the installation is vital for a dependable installation. A loose clamp will permit abrasion and often cause clamp breakage or even result in tube and/or fitting failure. The use of too small a clamp will almost always result in a broken clamp and subsequent tubing or fitting failure. We recommend a 25 pound minimum tension for tubes where no movement is desired, and a 10 pound maximum tension where movement is required.

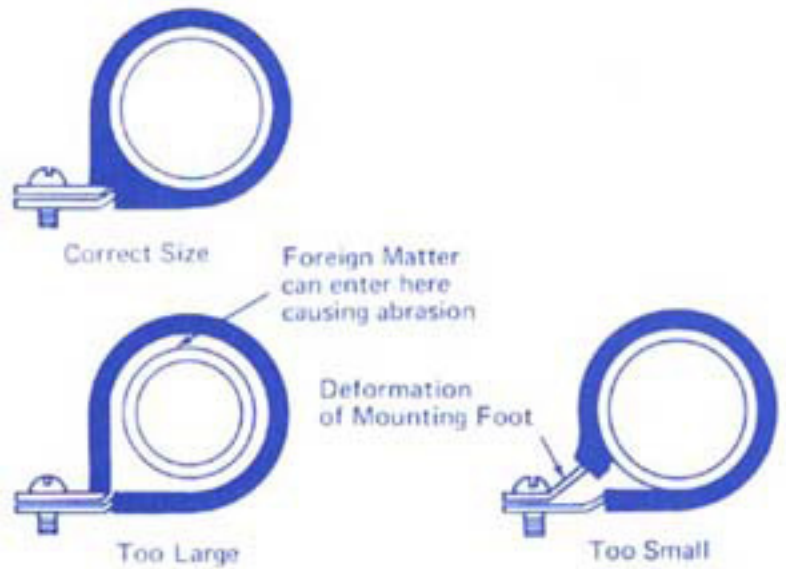

Position

The position of the clamp relative to the tube must be at 90° at installation to prevent built-in preload and subsequent clamp distortion and failure. Also clamp misalignment will cause abrasion or tearing of the cushion material resulting in a metal-to-metal condition, and a far greater abrasion problem. In some instances due to flexure or line surge, clamp swivel is experienced causing the condition shown. It is then necessary to substitute a clamp with 2 hole mounting to eliminate this condition. We recommend either TA's Regent, Flip-Loc, Saddle Style Clamps or Line Support Block. Consult TA's Engineering Department for the style best suited for your installation.

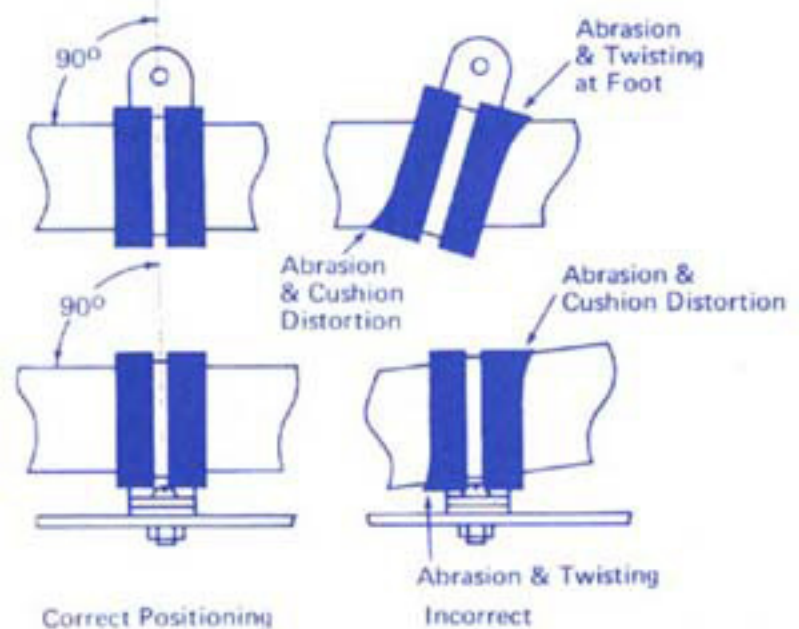

Tubing should be supported to rigid structure as close to the tube bends as possible as this is an area of pressure build-up and surge, especially in hydraulic and fuel systems. As tubing is no longer perfectly round after bending, the mechanic should check the tube for roundness, before positioning the clamp and securing it to the structure. **DO NOT** clamp on the tube bend or out of round areas in any case as this will distort the clamp causing abrasion and subsequent clamp and tube failure. Also, where possible the clamp mounting should be located to the inside of the bend for the best structural advantage.

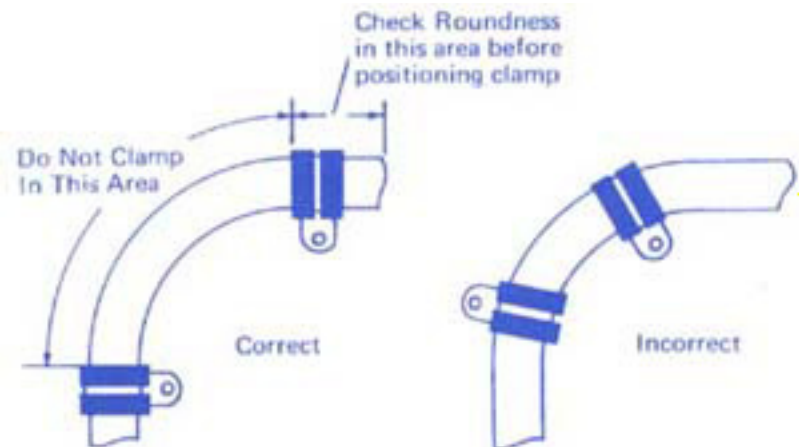

Mounting & Spacing

Spacing of clamps must be determined for each and every tube installation taking into consideration load, flexure, vibration, surges and other operational factors. Specification MIL-H-5440, notes maximum spacing and other criteria for aircraft hydraulic installations however, it too must be only used as a guide in view of the other variables which can be involved.

When mounting tubes to vertical structure the static load force should not oppose the mounting foot and bolt when using a single mounting point clamp. If the tube is mounted with the bolt below the tube, bending or distortion can and probably will result from either static load or personnel using the tubing as a handhold.

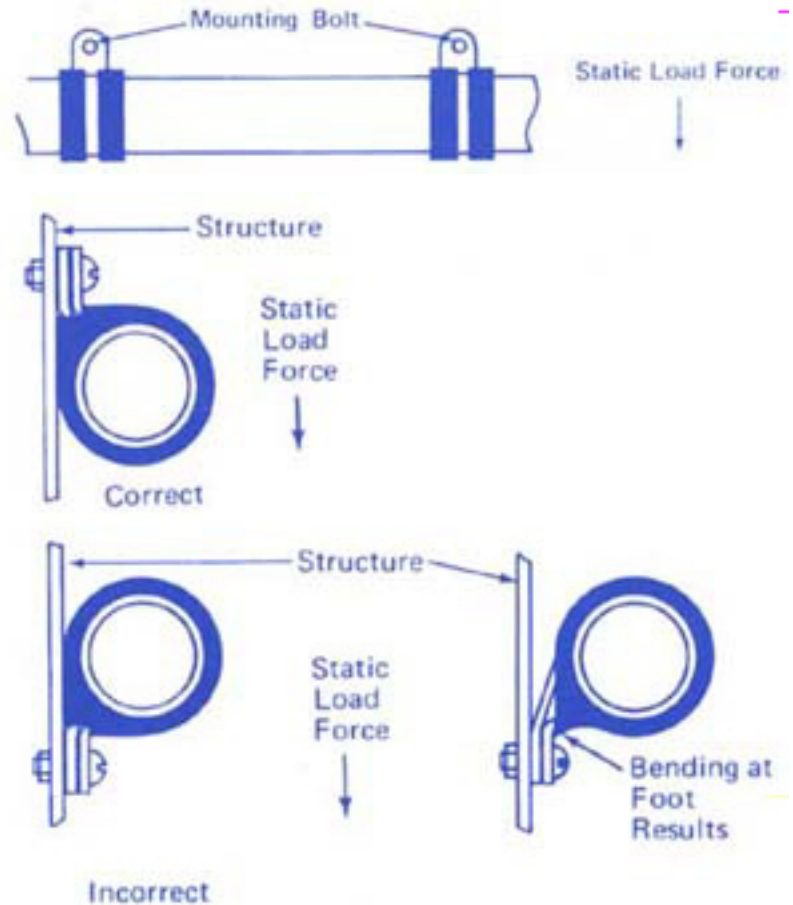

When surges, loads or flexure occur on installations to vertical or horizontal structure, it is good practice to alternate the mounting points to provide maximum support in both directions. If conditions are severe a Saddle Style Clamp may be necessary. If surge or flexure is in only one direction, the mounting should oppose the force.

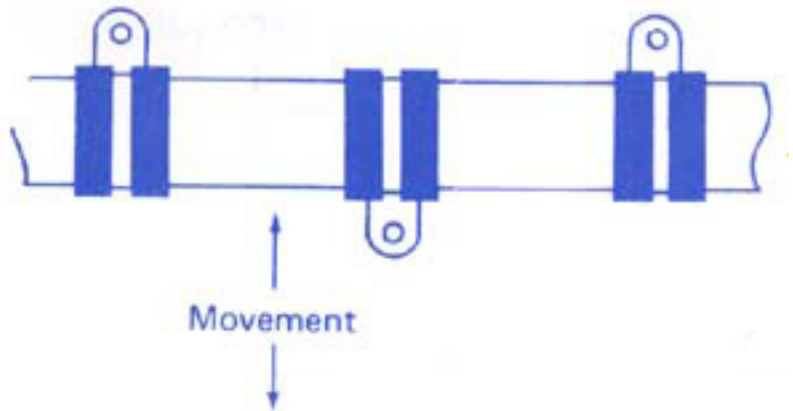

When surges or movement is parallel to the centerline of the tube, and the forces are sufficient to produce swiveling of single mounting point clamps, it becomes necessary to use 2 hole mountings. TA recommends the Regent Vibration Isolation Clamp, Section G, Saddle Type, Section G, Flip-Loc® Hinged Clamps, Section G or Line Support Block, Section H.

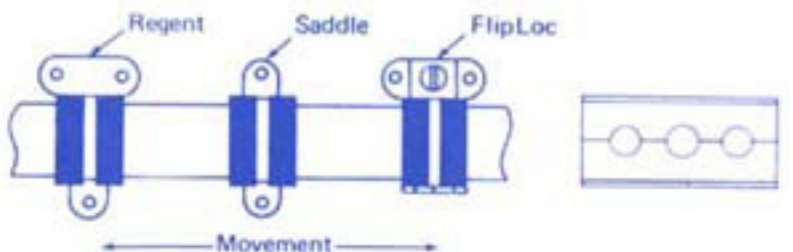

Stand-offs and Brackets are necessary for many tubing and wiring installations due to available structure and the line or cable separation required. Brackets are preferred over Stand-offs since they provide more support for the clamp and eliminate another piece of loose hardware, a principle cause of F.O.D. damage. Stand-offs should not be used under high vibration and surge conditions as swiveling, cocking and the high degree of clamp movement experienced with this cantilever type of mounting will ultimately result in clamp breakage. This same problem can result from cantilever mounting from brackets however to a lesser degree since the bracket will provide greater support under the clamp foot. See Section K for a wide variety of bracketry.

The common practice of mounting two or more clamps with a single bolt, known as "Butterflying", should be kept to a minimum. It not only increases maintenance costs, but in some cases requires Stand-offs accentuating the problems described above. Here again brackets or base mounting are preferred.

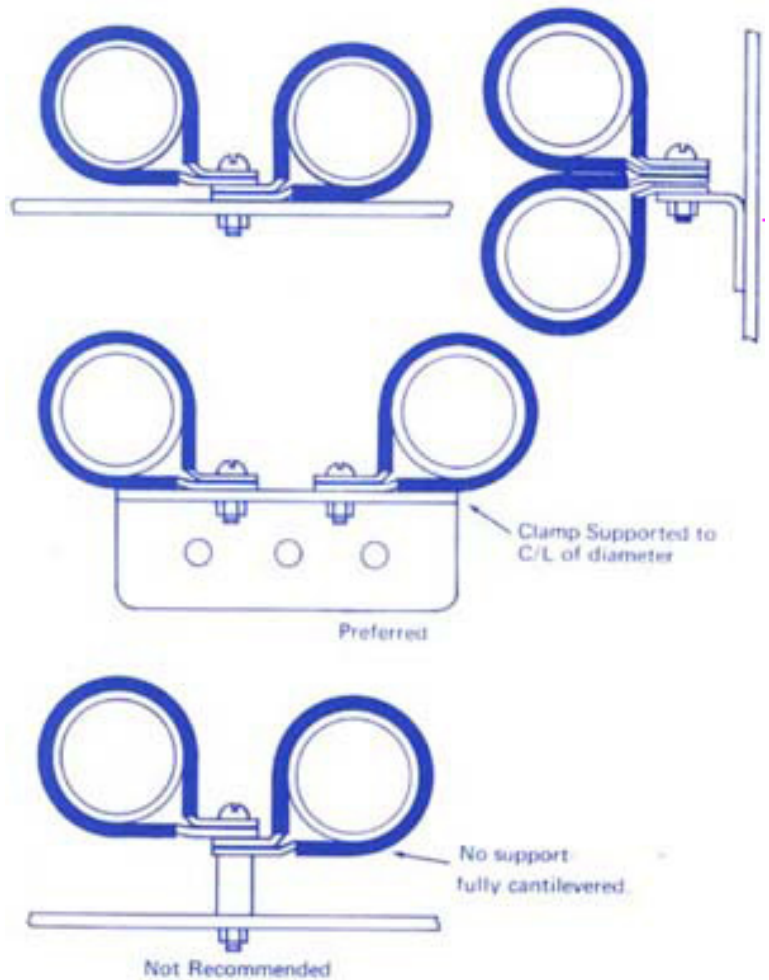
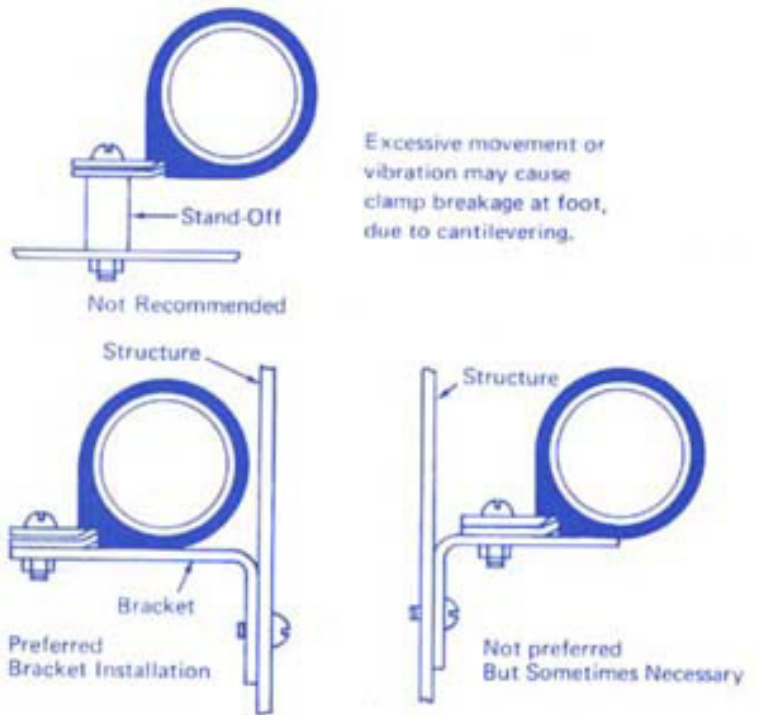

WIRING INSTALLATIONS

While the above discussions may be applicable to both tube and wire and cable installations, there are various situations common only to wire and cable installations. We will attempt to show and describe many of these conditions, however, we suggest consulting Specification MIL-W-5088 before proceeding with the design and installation of any wiring.

Bend Radius

The most common problem in wiring is a too small bend radii. This can be particularly critical on coaxial cable installations where crimping of the cable can cause multiple system failures. Another result of too small a bend radius is abrasion, which can result in electrical fires.

TA has upgraded the majority of their clamp cushion insulation materials to incorporate self-extinguishing fire requirements of the FAA and/or Underwriters Laboratories (See *Material Selection Guide*).

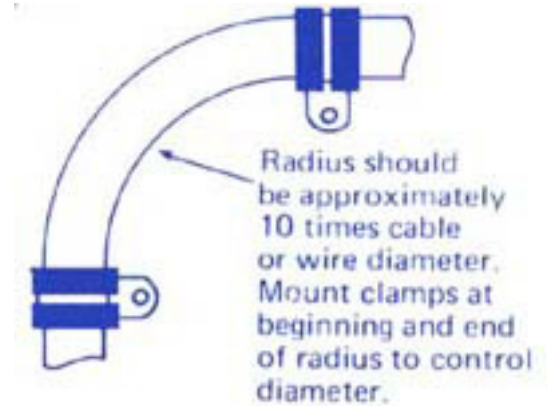

Fit

The tightness or fit of the clamp on the cable, wire or wire bundles is as important as with tubing installations. It depends on the location of the clamp, the area of installation and the systems being installed. For instance, cable restraint is desired just before terminal points whereas in high flex areas, where expansion loops are employed, a snug fit is sufficient.

For coaxial cable, snug clamping is desired, however care should be exercised NOT to exert too much pressure as it will degrade the installation. TA has incorporated a lower durometer rubber insulation into their standard materials (HA) for these low pressure clamping requirements. (See *Materials Selection Guide*)

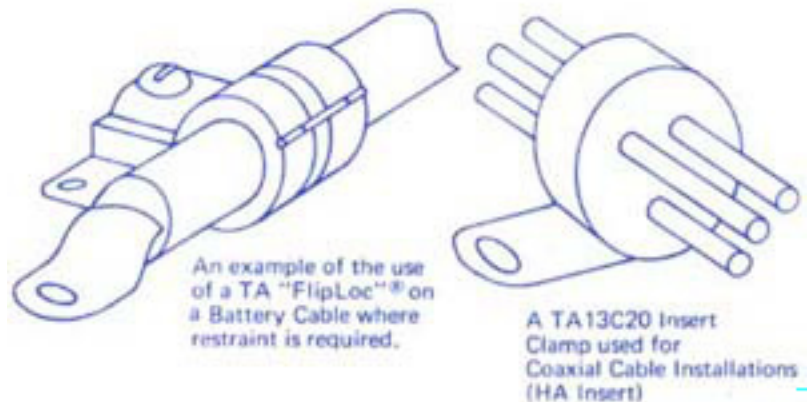

Clamp Spacing

Per Specification MIL-W-5088 spacing intervals of wires, cables and high density wire harnesses should not exceed 24 inches. However, here again the static weight, area of clamping and environment may dictate modification of this spacing.

Size and Configuration

Loop Style Clamps are not recommended for wire bundle installations over 1" diameter as the weight usually exceeds the structural capabilities of this style. Also, the use of too many wires per clamp, the more difficult and costly the maintenance. If, under some circumstances a large wire bundle is required, we suggest the use of a clamp with two hole mounting. See Sections G & H.

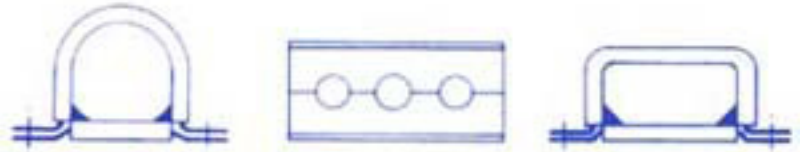

Many applications require the addition or removal of wires from bundles at frequent intervals. To make this type of maintenance less costly, we recommend the proven TA Quick Release Clamps, "Flip-Locs®", (See Section G) and our variable diameter cushion configuration, Page B2 of this Bulletin.



Of course, one feature of wiring clamp configuration which has become an industry standard is "WedgeSeal" (TA Patent No. 2,692,746). This feature insures against the trapping of wires under the clamp foot and assures even pressure over 360° of the tube or wiring installation.

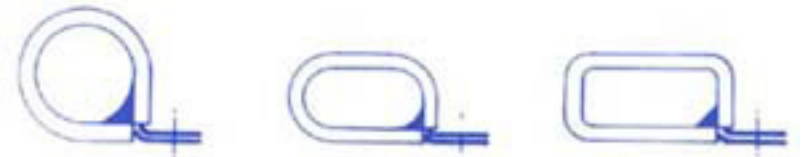

The use of wire ties has been costly and in some cases the cause of fires due to abrasion. Since bench preparation of wire bundles is necessary and clamps are always necessary for bundle installation, TA has developed a system eliminating the wire tie completely. It involves the pre-installation of a bracket and the use of a variety of Quick Release Flip-Loc® Clamps, (Section G). This system eliminates the possibility of F.O.D. damage as it employs all captive hardware. Consult your TA Representative for the Flip-Loc® Clamp best suited for your wiring installation.

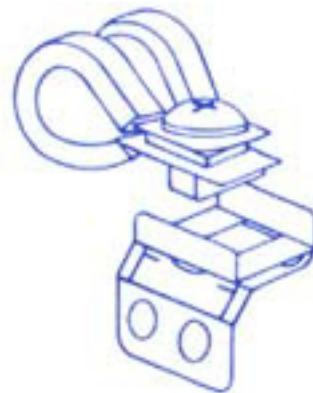

Clamp Reuse

The reuse of clamps may be satisfactory in many applications, however, before reinstalling check the condition of the cushion insulation, metal clamp band and the mounting hole. If the mounting hole or the metal clamp band is deformed in any way, the clamp should be scrapped and one of the identical configuration and Part Number used as a replacement. The substitution of “similar” clamps can cause major problems such as misalignment and pre-load, and lack of environmental computability.

There are areas and environments in which it is never a wise practice to reuse clamps. These are on engines, particularly aircraft turbojets, where they have been subject to thousands of hours of heat cycling and vibration. Both of these conditions tend to fatigue the metal, and breakdown of the rubber structure. This same condition to varying degrees may prevent clamp reuse in other areas such as on the pressure lines of hydraulic systems, and hydraulic and wiring clamps in aircraft engine pylons and wings.

TA has endeavored to develop clamps which will permit reuse after maintenance functions and until major overhaul Service experience and tests have proven the TA “Flip-Loc®” Hinged Clamps will accomplish this feat in the most rugged turbofan engine environments. The use of 17-7PH Precipitation Harden Stainless Steel provides a clamp which will not deform readily, thus permitting many reuse cycles. Tests have also proven that the use of our new Regent Vibration Isolation Cushions, even on the simple loop style clamps will increase the metal band life by approximately 250%. See Section G, Bulletin 2000.