

Bulletin 1800: FLIP-LOC RECTANGULAR HINGED MOUNTING BRACKET FIXED

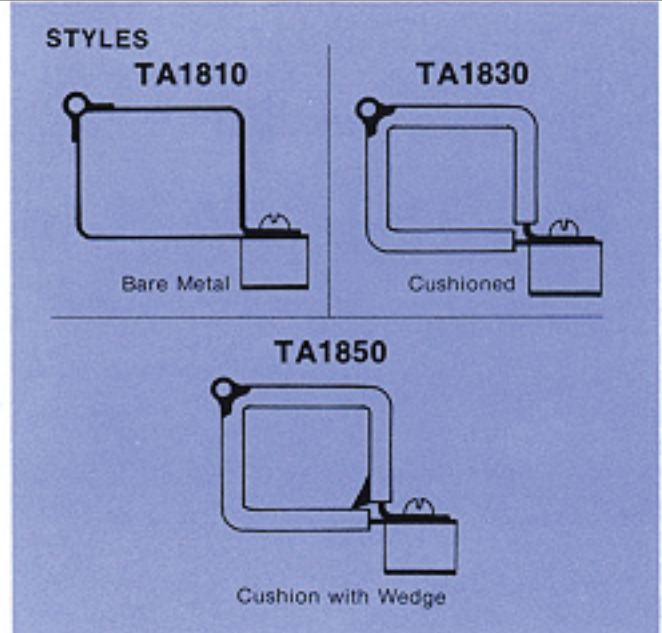
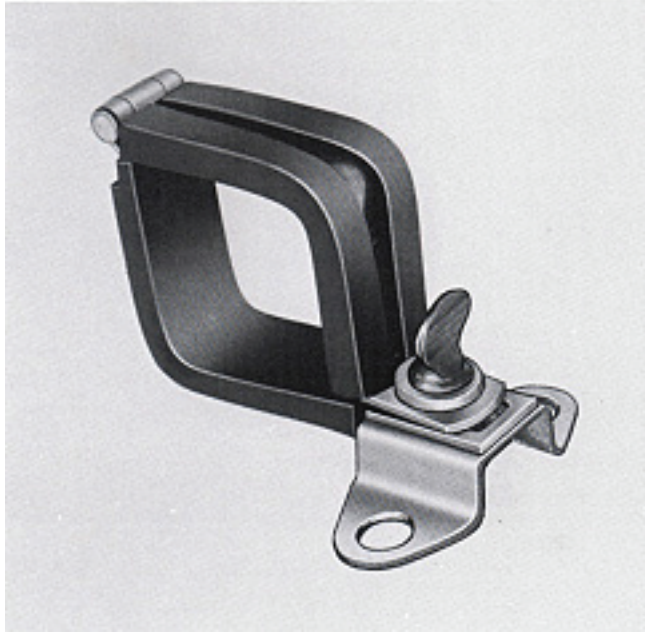

Part Numbering System

ex: **TA1830-20HB2001** = Flip Loc clamp, rectangular, hinged, stainless steel, 1/2 wide band with 2 hole mounting bracket, Silicone (HB) cushion, slot head screw (1/4 turn lock), for tube size 1-1/4 square.

Breakdown:

Part number shown below is separated for clarity. When ordering, do not show spaces.

TA1830 = 20 HB 20 01

- TA1830 = Basic Part Number
- = Bracket as Shown (For options, see Bulletin 1000A)
- 20 = Size A in 1/16" Increments (Show as a minimum of 2 digits)
- HB = Cushion or Insert Material Code (See Bulletins 120 and 130) (Use dash (-) for Style TA 1810)
- 20 = Size B in 1/16" Increments (Show as a minimum of 2 digits)
- 01 = Screw Head Option (See Bulletin 1000A)

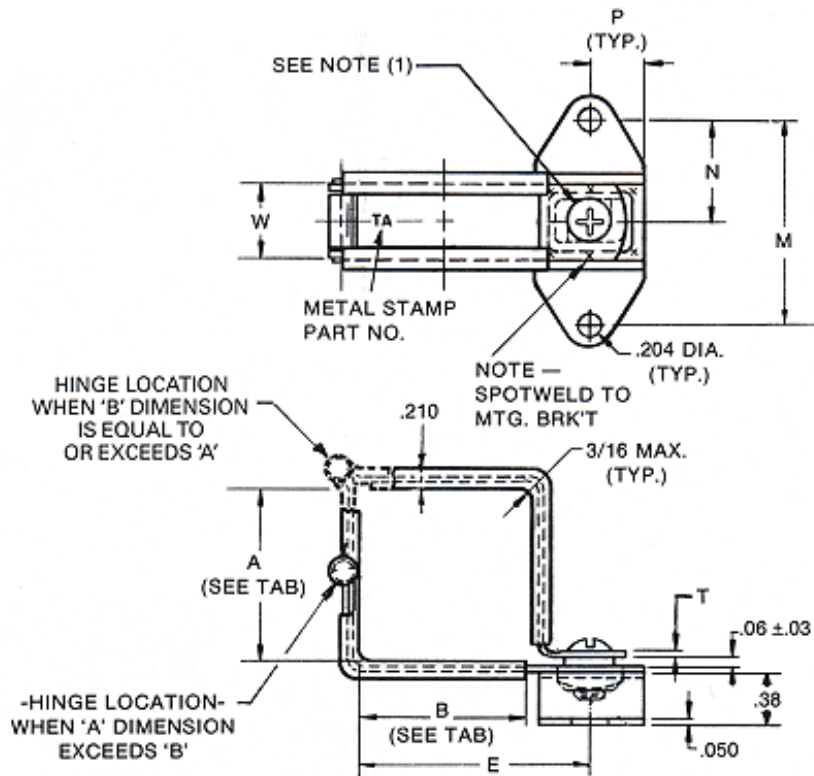

Diagram ID ▶	Corner Hinge (min.)		Center Hinge (min.)		Strap Width W	Metal Gauge T	Mounting Dimension E	M	N	P
	A	B	A	B						
Tolerances ▶					+/- .005	per spec	+/- .030	+/- 1/32	+/- .015	+/- .015
Part Number										
TA1810 -()()()	-06	-06	-14	-06	1/2	.040	B+.463	1-1/4	5/8	3/8
TA1830 ¹ -()()()	-06	-06	-14	-06	1/2	.040	B+.523	1-1/4	5/8	3/8
TA1850 ¹ -()()()	-06	-06	-14	-06	1/2	.040	B+.523	1-1/4	5/8	3/8
TA1811 ² -()()()	-08	-08	-16	-08	3/4	.050	B+.473	1-3/4	7/8	13/32
TA1831 ¹ -()()()	-08	-08	-16	-08	3/4	.050	B+.533	1-3/4	7/8	13/32
TA1851 ¹ -()()()	-08	-08	-16	-08	3/4	.050	B+.533	1-3/4	7/8	13/32

- 1 Non-cushioned
- 2 Cushioned

Material: Band and bracket: 321 stainless steel, annealed per AMS 5510
Finish: Ball burnished and passivated per AMS 2700

Note 1: Screw head options, see Bulletin 1000A.

Screw size (not optional) per strap width, 10-32 screws are used on 1/2 wide strap clamps, 1/4-28 screws are used on larger widths.

Dimensions in inches

This document is the property of Kirkhill-TA and is conveyed with the express condition that it and the information contained in it are not to be used, disclosed or reproduced in whole or in part, for any purpose without the express written consent of Kirkhill-TA; and that no right is granted to disclose or so use any information contained in said document. These restrictions do not apply to vendor proprietary parts.