



SPECIFICATION

For

SWITCHING POWER SUPPLY

M/N: MPD-F113-1

Revision History

REV.	Jan. 7 th 2010	Updated mechanical drawing for adding position of fixing holds.
REV.	Mar. 4 th 2010	Update the description of efficiency, inrush current and the criteria of EMI.
REV.	Mar. 17 th 2010	Update the EMS specification.
REV.	Mar. 28 th 2011	Updated safety approvals status.
REV.	Nov. 25 th 2011	Revised the initial setting accuracy.
REV.	Jul. 5 th 2012	Updated safety approvals status.
REV.	Jun. 4 th 2013	Added recommended torque of input connector.
REV.	Nov. 25 th 2015	a)Added vibration test b) Added "or equivalent" after "Molex" and " Dinkle"
REV.	Dec.21 th 2015	Changed Over Voltage Protection 15V to 16V
REV.	Dec 20 th 2016	1. Changed 60950-1 to A2: 2013 2. Changed IEC 61000-4-3: 2002 to 10V/m 3. Changed IEC 61000-4-6: 2006 to 10V
REV.	Mar 08 th 2017	Added 50°C and 70°C input derating drawing



FEATURES

- 110W isolated DC/DC converter with 11.7 CFM forced air-cooling, 70W convection cooled
- Fully isolated primary and secondary
- Wide input range 9-32VDC
- Compact size 2 x 5 inch
- Low inrush current to prevent power adapter turn on issue
- Input polarity reversed protection
- Built in DC input on/off switch controller
- High efficiency up to 89%
- UL 60950-1 2nd edition approved



1. Description

The MPD-F113-1 is a 110W single output DC/DC converter. It is a compact size 2 x 5" and wide input range from 9-32VDC. Fully isolated primary to secondary avoid disturbed noise to affect secondary side. The low inrush current is 3A max. for preventing turn on issue and protecting the power supply. The built in DC input on/off switch controller can use with a normal on/off switch, instead of high rated current switch, and TTL signal control is available as well (see 8. application note). In addition, design in polarity reverse protection to avoid wrong input polarity.

Output Voltage	Min. Output Current	Rated Output Current	Max. output Current ^(Note 1)	Line Regulation	Load Regulation	Ripple & Noise p-p ^(Note 2)	Initial Setting Accuracy ^(Note 3)
+12V	0A	5.8A	9.2A	±1%	±1%	120mV	11.76V to 12.24V

Total Output Power: 110W at 50°C environment temperature^(Note 4).

Note: 1) When output current above 5.8A, it has to force air cooling 11.7 CFM.

2) Measured by a 20MHz bandwidth limited oscilloscope and the each output is connected with a 10µF Electrolytic capacitor and a 0.1µF Ceramic Capacitor.

3) At factory, all outputs in 60% rated load. The +12V output is set to between 11.88V and 12.12V.

4) The total DC continuous power shall be kept with 70W at input from 18V to 32VDC; 65W at input from 12V-17.9VDC; 60W at input from 9-11.9VDC convection cooled and 110W at input from 12 to 32VDC; 95W at input from 9 to 11.9VDC with force air cooling 11.7 CFM.

2. Input Specification

Parameter	Conditions/Description	Min.	Nom.	Max.	Units
Input Voltage	Continuous input range.	9	12/24	32	VDC
Input Current	DC Input Voltage 10VDC, rated load.			13	A
Inrush Current ^(Note)	Nominal DC Input Voltage (12/24VDC), cold start at 25°C.			3	A

Note: No output voltage during this period. (see as below)

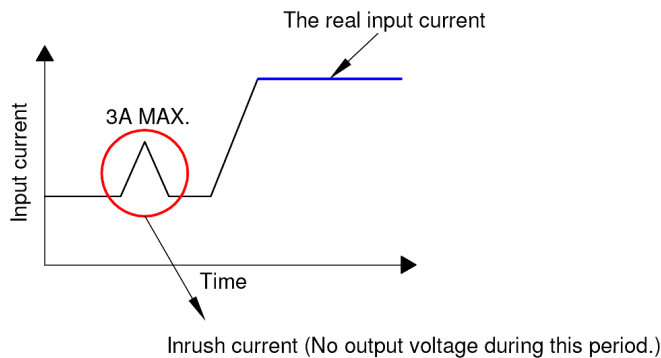



3. Output Specification

Parameter	Conditions/Description	Min.	Nom.	Max.	Units
Efficiency	At input voltage 12/24V, rated load condition.		88	89	%
Minimum load					See Chart of Description
Ripple & Noise	Rated load, 20MHz bandwidth				See Chart of Description
Output Power	Continuous output power.				See Chart of Description
Line Regulation	Less than $\pm 1\%$ at rated load with $\pm 10\%$ changing in input voltage +12V and +24V.				See Chart of Description
Load Regulation	Measured from 60% to 100% rated load and from 60% to 20% rated load ($60\% \pm 40\%$ rated load) for each output, and others voltage setting at 60%.				See Chart of Description

4. Interface Signals and Internal Protection

Parameter	Conditions/Description
Short Circuit or Over Load Protection	The power supply will go into hiccup mode against short circuit or over load conditions, and will auto-recovery while fault conditions moved.
Input On/Off switch	(1) Use a switch to short pin1 and pin2 of SW1 to turn on the power supply. (2) Or, it can use TTL signal to control the power on/off (please see more detail at Application Note).
Over Voltage Protection	For some reason the power supply fails to control itself, the build-in over voltage protection circuit will shut down the outputs to prevent damaging external circuits. The trigger point is from 12.8V to 16V.

5. Safety Approvals, EMI and EMS Specification

Parameter	Conditions/Description	Min.	Nom.	Max.	Units
Approvals	IEC 60950-1: 2005+A2: 2013, 2 nd				CE (LVD) approved
	EN 60950-1: 2006+A2: 2013				
	UL 60950-1, 2 nd Edition, 2011-12-19				UL, cUL approved ^(Note 3)
	CSA C22.2 No.60950-1-07, 2 nd Edition, 2011-12				
Radiation ^(Note 1, 2)	EN 55022 / CISPR 22 & FCC Part 15	A			Class
Conduction	EN 55022 / CISPR 22 & FCC Part 15	B			
EMS	IEC 61000-4-2: 2001, 8KV air discharge, 6KV contact discharge	A			Criteria
	IEC 61000-4-3: 2002, 10V/m	A			
	IEC 61000-4-4: 2004, 0.5KV line & PE	A			
	IEC 61000-4-5: 2001, 0.5KV line to line	A			
	IEC 61000-4-6: 2006, 10V	A			

Note: 1) As a build-in type power supply, the power supply needs to be installed in a suitable enclosure to pass the EMI/EMC tests. The final assembly has to comply with the valid EMI/EMC and safety.

2) With Class B radiation is required an additional ferrite core (Erocore / A8H142150090, please contact with us.) string on input (+, -) wires.

3) 70W output power certified.

6. Environment Specification

Parameter	Conditions/Description	Min.	Nom.	Max.	Units
Operating Temperature	Derate linearly above 50°C by 1.5% per °C At 100% load:	-10		+50	°C
	to a maximum temperature of 70°C At 70% load:			+70	
Storage Temperature		-20		+75	°C
Relative Humidity	Non-condensing.	10		90	%RH
Altitude	Operating			2K	meter

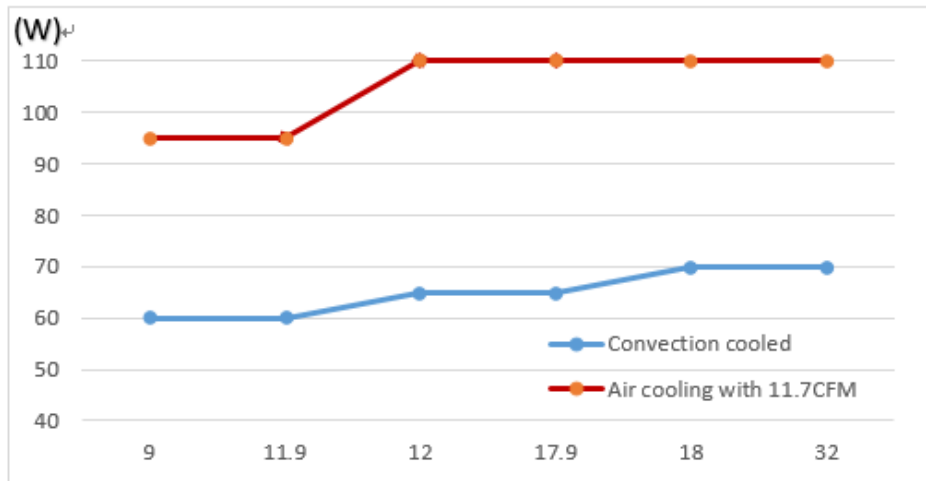

Input Voltage (VDC)

Performance curves of MPD-F113-1 (12V output @ 50°C)

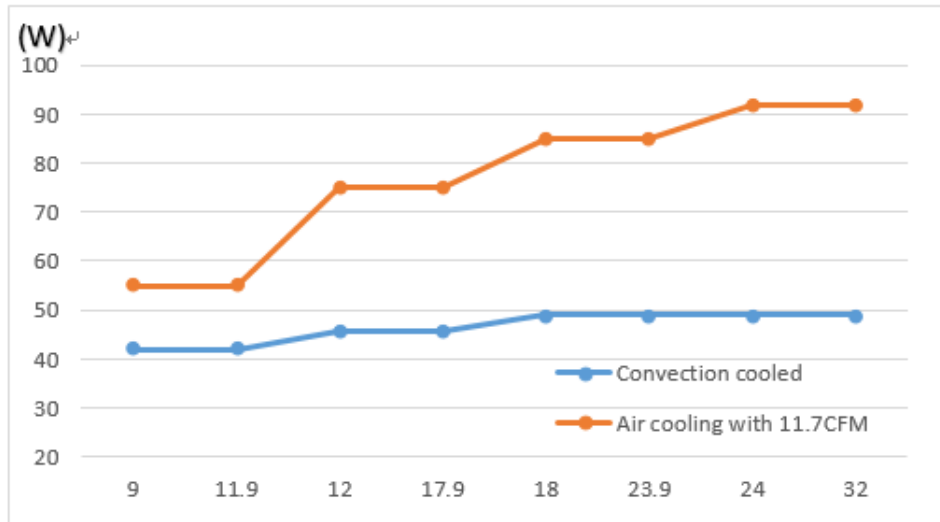

Input Voltage (VDC)

Performance curves of MPD-F113-1 (12V output @ 70°C)

7. Mechanical Specification

Parameter	Conditions/Description				
Dimension	50.8 (L) x 127 (W) x 31.5 (H) mm, Tolerance +/- 0.5mm.				
Connector	CN1 --- DC input: Dinkle ED500V-02 Terminal blocks or equivalent. CN2 --- DC output: Molex 5273-04A or equivalent. FAN --- Output: Molex 5045-02A or equivalent. SW1 --- Remote on/off Molex 5045-02A or equivalent.				
Pin Assignment	CN1	Pin	1. +	2. -	(With max. torque=0.4N*m)
	CN2	Pin	1. +12V	3. GND	
			2. +12V	4. GND	
	FAN	Pin	1. +12V	2. GND	
	SWITCH	Pin	1. +	2. -	



Dimension

50.8 (L) x 127 (W) x 31.5 (H) mm, Tolerance +/- 0.5mm.

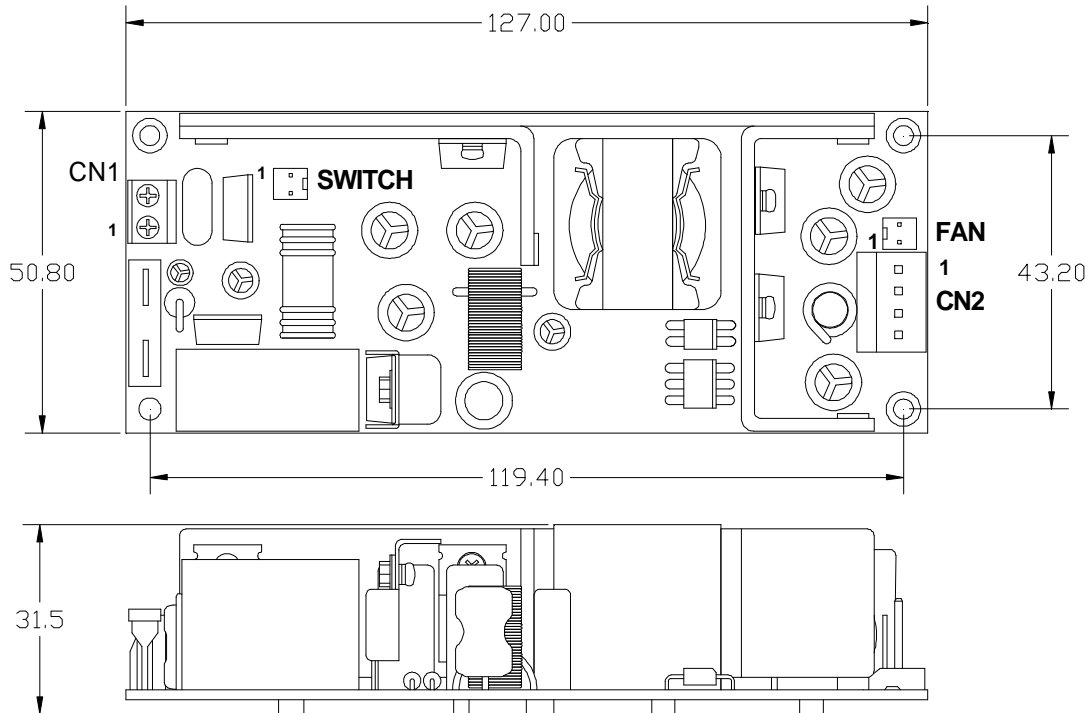

8. Application Note

Please refer circuit below when use TTL to control the PSU turning on/off.

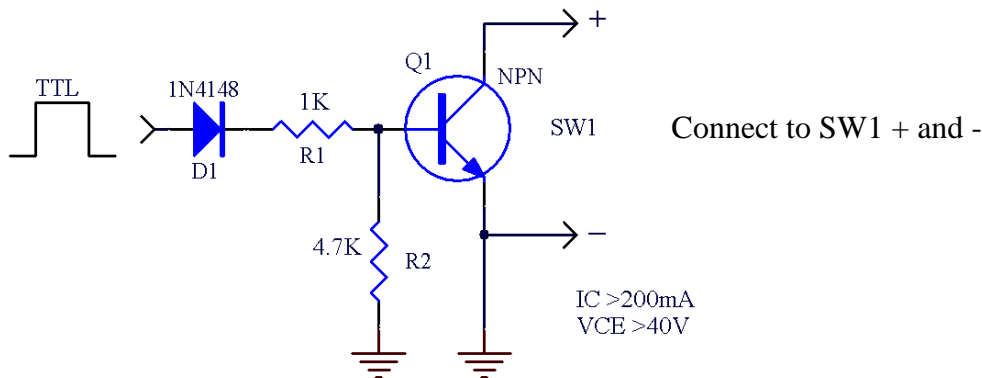

9. Vibration Test

Parameter	Conditions/Description
Ambiance Condition	Temperature : 20~35°C Humidity : 50~75 %RH
Test Standard	IEC 60068-2-6
Test Condition	Frequency Type : Sweep Frequency Frequency Range : 10~55 Hz Sweep Rate : 60 minute / cycle Number of cycle : 1 cycle / axis Direction : X , Y and Z axis