



1.0 INTRODUCTIONS

MPD-830C is an off-line DC 24V input switching power supply. It is ideal for use in ATX personal computers, workstations, and equivalent systems. This power supply has designed to meet UL, CSA, and TUV safety approvals.

2.0 INPUT SPECIFICATIONS

2.1 Input Voltage

The range of input voltage is from +19VDC to +32VDC.

2.2 Input current

The maximum input current is 20A at +24VDC input.

2.3 Inrush current

The inrush current will not exceed 5A at +24VDC input cold start 25°C.

3.0 OUTPUT SPECIFICATIONS

3.1 The load range

Output voltage	Min. load	Rated load	Max. load	Voltage accuracy
+5V	2A	25A	30A	4.80V to 5.20V
+12V	0.1 A	10A	15A	11.40V to 12.60V
-12V		1A	2A	-11.40V to -12.60V
-5V		1A	2A	-4.75V to -5.25V
+3.3V		8A	15A	3.13V to 3.40V
+5Vsb		0.72A	1.2A	4.75V to 5.25V

At factory, all outputs in 60% rated load condition; the +5V output is set to between 4.90V and 5.10V the other outputs can be used single and checked to be within the specified voltage accuracy range.

3.2 Output power

The total DC continuous power shall be kept within 300W ambient temperature of 30°C below, and input voltage at +24V ~ +32V. When input voltage is +19V ~ +23V the total DC continuous power shall be kept within 250W. The maximum total combined output power on the 3.3V and 5V rails is 150W.

3.3 Ripple & Noise

The peak to peak ripple and noise for +5V, +3.3V output is less than 50mV, and other output is less than 100mV of output voltage at rated load. Measuring is done by 15MHz bandwidth limited oscilloscope and terminated each output with a 0.47μF capacitor.

3.4 Line regulation

The line regulation for each output is less than +/-1% while measuring at rated load and +19V to +32V of input voltage changing.



3.5 Load regulation

The output voltage load regulation is less than the value in the following table by changing each output load +/-40% from 60% from rated load, and keep all other outputs at 60% rated load.

Output	#1	+/-3%	#4	+/-2%
	#2	+/-5%	#5	+/-2%
	#3	+/-2%	#6	+/-3%

4.0 GENERAL FEATURES

4.1 Efficiency

The efficiency is higher than 65% while measuring at nominal line and rated output.

4.2 Protection

4.2.1 Over voltage protection

For some reasons the power supply might fail to control itself, the build-in crowbar circuit will automatically shut down the outputs to avoid damaging the external circuits. The trip point of O.V.P. circuit is around 5.7V to 7.0V.

4.2.2 Short circuit protection

The power supply will go into hiccup mode function against short circuit or over load conditions. If the faults condition removed, the power supply will restart automatically.

4.3 Power good signal

When power start-up, the power good signal will go between 100ms to 500ms high after all output DC voltages are within regulation limits.

4.4 Power fail signal

The power fail signal will low down at least 1ms before any of the output voltages fall below the regulation limits.

4.5 Power ON signal

This TTL compatible signal (active low) is use to switch ON the main output. When Power on is disconnected from secondary common, all outputs except +5Vsb shall turn off.



5.0 ENVIRONMENT SPECIFICATIONS

5.1 Operating temperature

0°C to 70°C (-20°C can start up)

The output power should be derated as following curve:

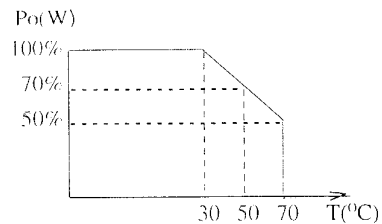

5.2 Storage temperature

-40°C to +75°C

5.3 Operating humidity

The power supply can operate from 5% humidity to 95% humidity non-condensing at 40°C.

5.4 Altitude

Will operate properly at any altitude between 0 to 10000ft.

6.0 INTERNATIONAL STANDARDS

6.1 Safety standards

Designed to meet the following standards:

UL 1950

CSA 22.2 No. 234

EN 60950

6.2 EMI standards

Designed to meet the following radiated limits:

FCC class "B"

EN55022 class "B"

6.3 EMS standards

Designed to meet the following standards:

IEC-801-2 8KV air discharge

IEC-801-3 3V/M

IEC-801-4 2KV



7.0 MECHANICAL SPECIFICATION

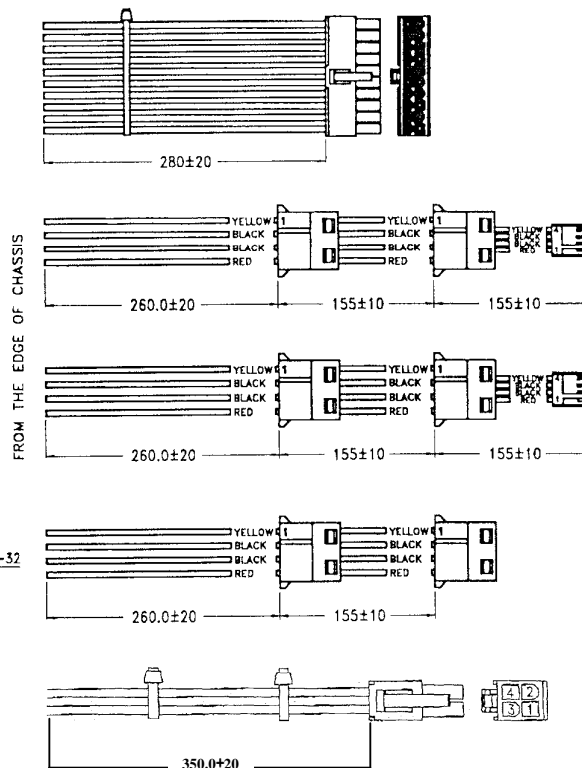
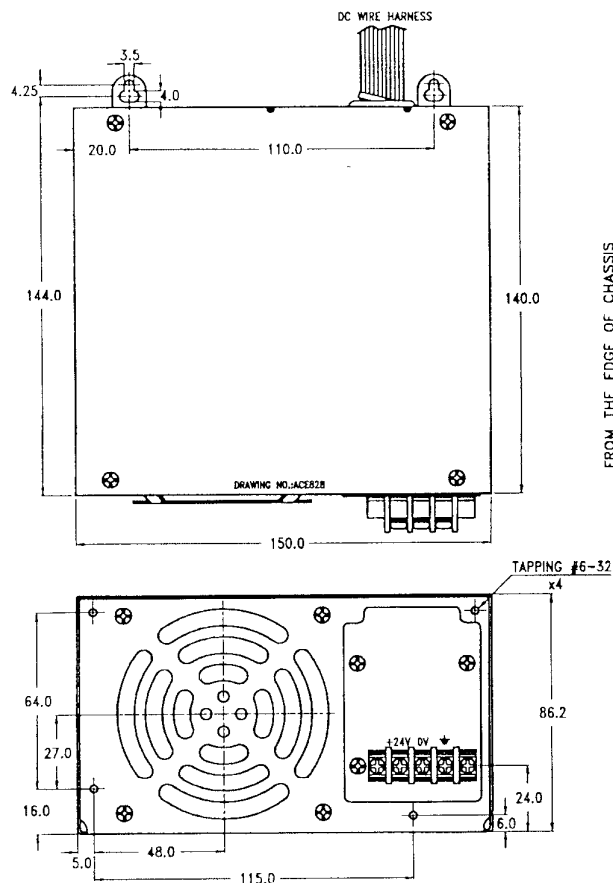

Wire Color	VOLTAGE
ORANGE	3.3V
RED	5V
YELLOW	12V
BLUE	-12V
GREY	P.G.
WHITE	-5V
BLACK	GND
PURPLE	+5Vsb
GREEN	POWER ON

7.1 Dimensions

Dimensions are shown in mm as above

Tolerance specified is +/-0.4mm between mounting holes, +/-0.8mm for other dimensions.

7.2 DC Connectors

3 positions terminal blocks

7.3 DC connectors

- ATX : Molex 39-01-2200 or equivalent.
- Disk drive : AMP 1-480424-0 or equivalent.
- 3 1/2" floppy driver : AMP 171822-4 or equivalent.
- P4 : Molex 39-01-2045 or equivalent.