

MARKING

Fagor Electrónica Semiconductores

LEGEND

MC: Fagor Marking code

WW: Week code

Y: Year code

: Fagor logo

: UL mark (When required)

: Circuit diagram

HALOGEN FREE

: HF: In Axial=>Add suffix HF in Fagor Marking code when Halogen Free is required.
 H: In all other packages => Add suffix H in front of WW (Week code) when Halogen Free is required. HWW

+: Positive polarity

-: Negative polarity

~: Alternate

Week code: Manufacturing week => 01/02/03/04/05/06/07/08/09/10/11/...../52/

Year code:

Calendar	2001	2002	2003	2004	2005	2006	2007	2008	2009	2010	2011	2012	2013	2014	2015	2016	2017	2018	2019	2020	
Year code	A	B	C	D	E	F	H	J	K	L	M	N	P	R	S	T	U	V	W	X	A

MARKING

Fagor Electrónica Semiconductores

DIODES

AXIAL MARKING

DIODES

Package: DO-35 / A-405 / DO-41M / DO-204AL (DO-41) / DO-204AC (DO-15) / DO-201AE / DO-201AD (DO-27) / P-6 / R-6

Package: DO-35

DO-35

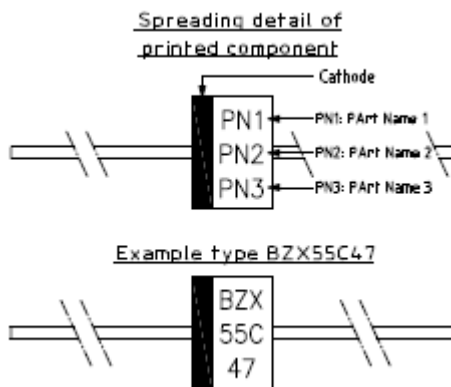

DO-41 MINI

Spreading printing detail

Example

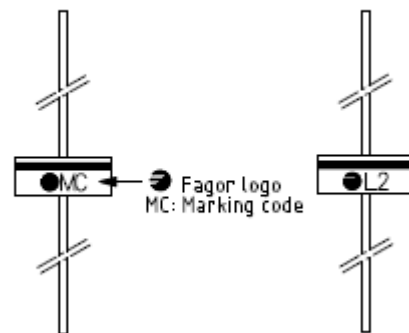

A-405 / DO-204AL (DO-41) / DO-204AC (DO-15) / DO-201AE / DO-201AD (DO-27) / P-6 / R-6

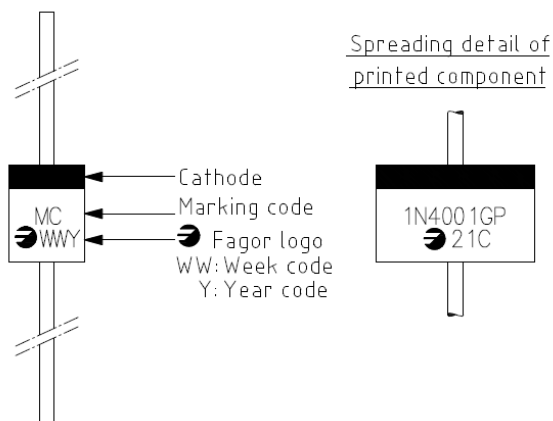

* No cathode band for bidirectional.

* HF: Halogen free products MC finished in HF; eg.1N4001GPH

MARKING

Fagor Electrónica Semiconductores

SMD MARKING

DIODES

Package: DO-214AC (SMA) / DO-214AA (SMB) / DO-214AB (SMC) / SOD123W / SOD128 / POWER SMD1 / DO-213AA (MINIMELF) / TO-263AB (D2PAK) / TO-252AA (DPAK)

DO-214AC (SMA)/DO-214AA (SMB)/DO-214AB (SMC)

SOD123W/SOD128/POWER SMD1

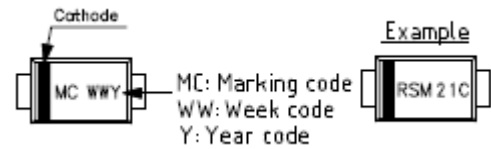
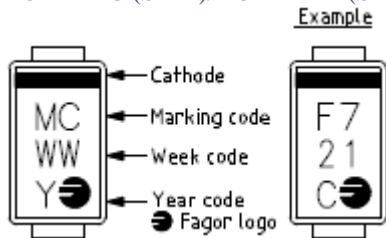

DO-213AA (MINIMELF)

TO-263AB (D2PAK) / TO-252AA (DPAK)

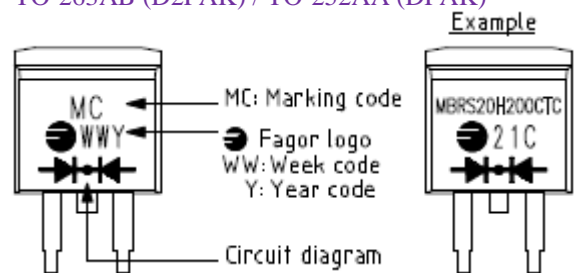
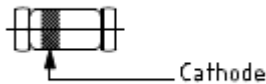

* No cathode band for bidirectional.

* H: Halogen free products add suffix H before WW week code; eg.H21

POWER PACK MARKING

DIODES

Package: TO-220AC / TO-220AB / ITO-220AC / ITO-220AB / TO-247AD (TO-3P)

TO-220AC / ITO-220AC

TO-220AB / ITO-220AB

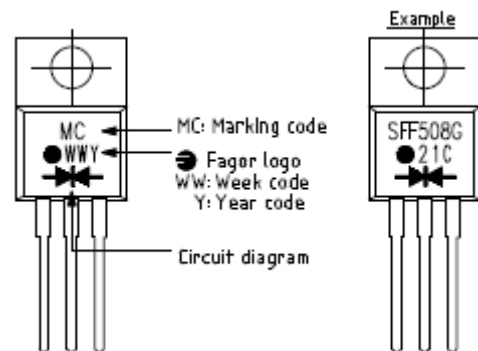
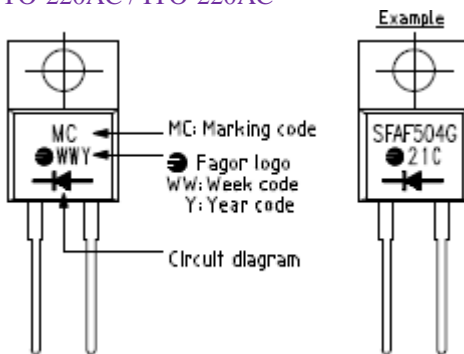

TO-247AD (TO3P)

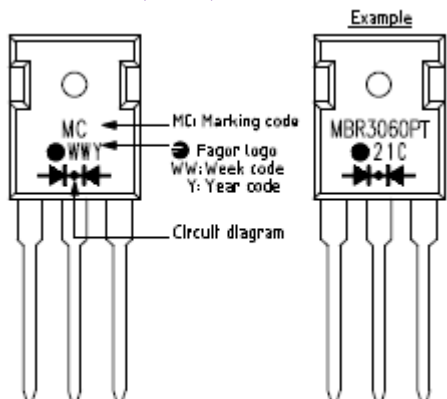

MARKING

Fagor Electrónica Semiconductores

BRIDGES

IN LINE MARKING

BRIDGES

Package: GBL / GBU / DSB MEDIUM IN LINE / DXB BIG IN LINE

GBL

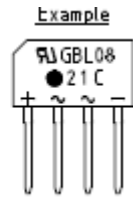
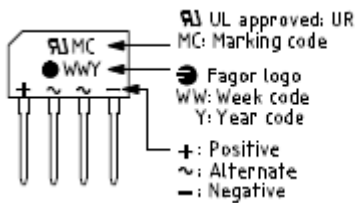

GBU

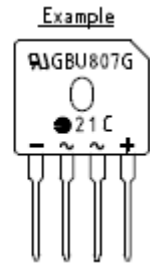
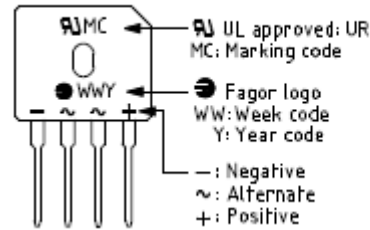

DSB MEDIUM IN LINE

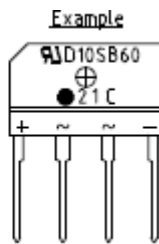
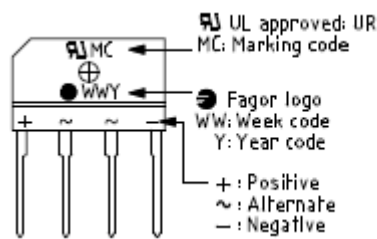

DXB BIG IN LINE

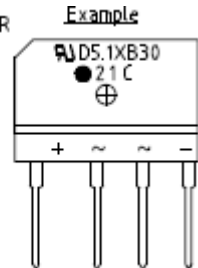
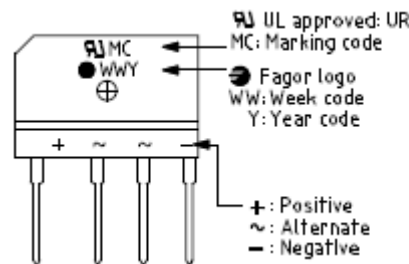

SMD MARKING

BRIDGES

Package: TO-269AA (MBS) / DFS / THIN DFS / THIN MINI DIP

TO-269AA (MBS)

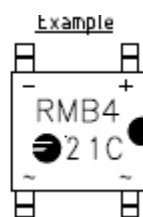
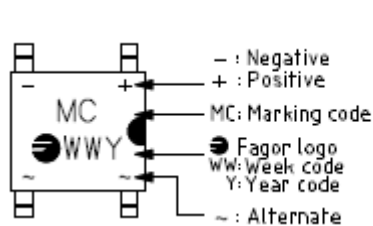

DFS / THIN DFS

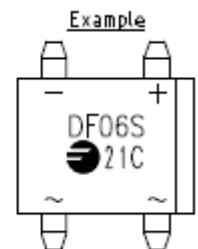
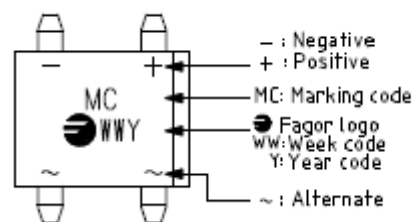

THIN MINI DIP

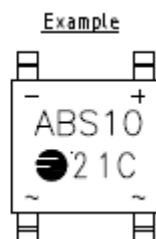
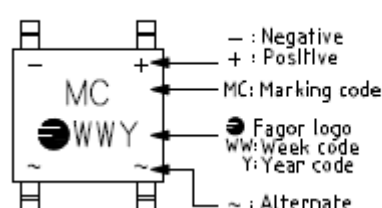

MARKING

Fagor Electrónica Semiconductores

RADIAL/THROUGH HOLE MARKING

BRIDGES

Package: DFM / THIN DFM

DFM / THIN DFM

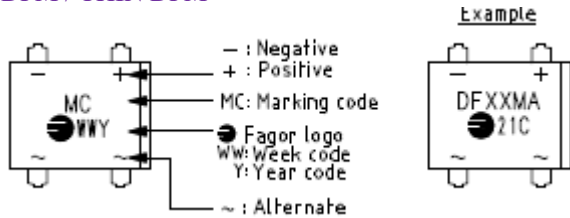

FASTON/WIRED MARKING

BRIDGES

Package: POWER / POWER L

POWER

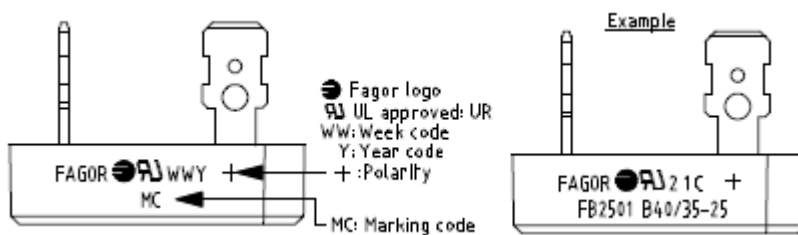

POWER L

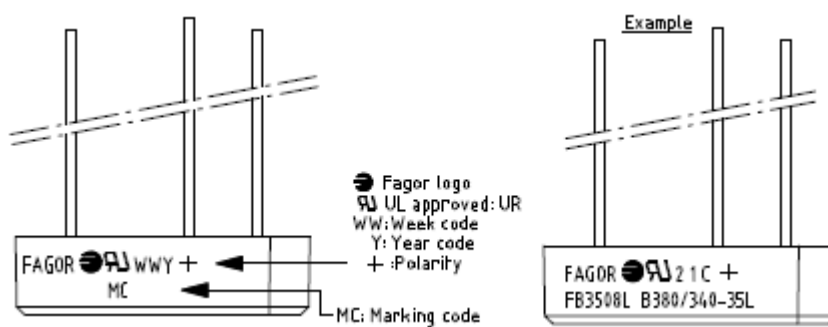

MARKING

Fagor Electrónica Semiconductores

THYRISTORS

AXIAL MARKING

THYRISTORS

Package: DO-35

DO-35 DIAC

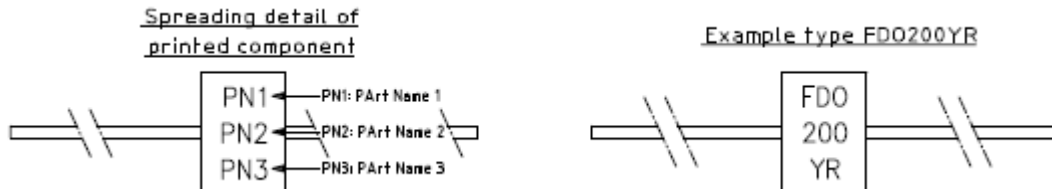

SMD MARKING

THYRISTORS

Package: TO-261AA (SOT-223) / TO-236AB (SOT-23 3L) / TO-252AA (DPAK) / TO-263AB (D2PAK) / DO-213AA (MINIMELF)

TO-261AA (SOT-223)

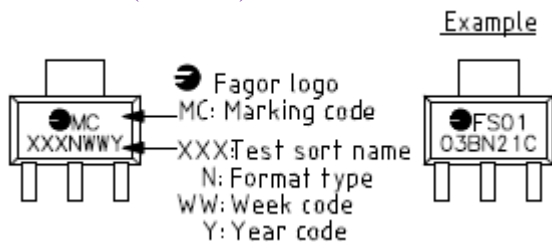

TO-236AB (SOT-23 3L)

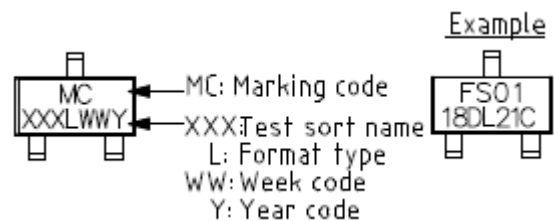

TO-252AA (DPAK)

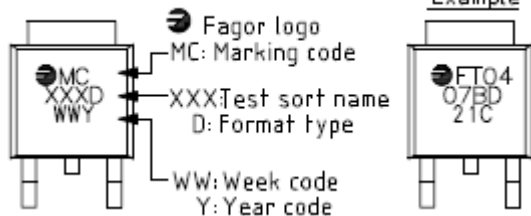

TO-263AB (D2PAK)

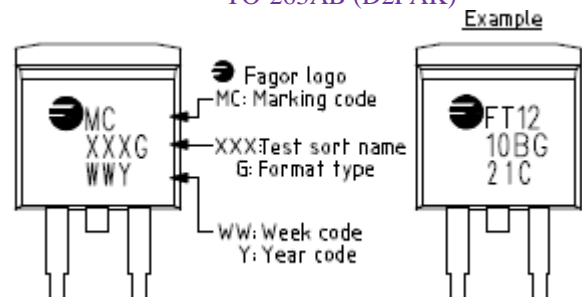

DO-213AA (MINIMELF)

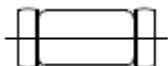

MARKING

Fagor Electrónica Semiconductores

THROUGH HOLE MARKING

THYRISTORS

Package: TO-226AA (TO-92) / TO-251 (IPAK)

TO-226AA (TO-92)

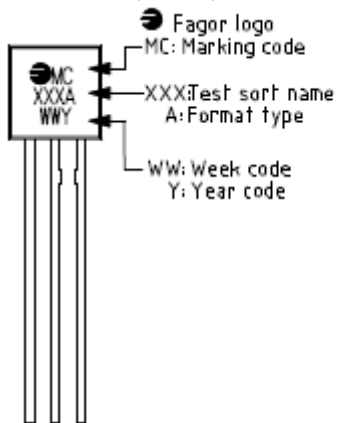

Example

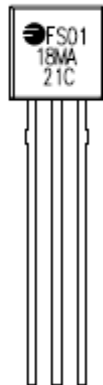

TO-251 (IPAK)

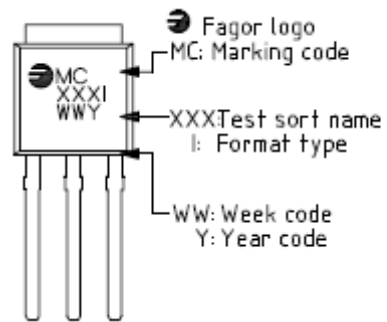

Example

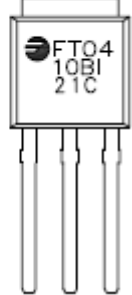

POWER PACK MARKING

THYRISTORS

Package: / TO-220 AB / TO-220 AB INSULATED / TO-220 F / TO-3P INSULATED / TO-3P FP

TO-220 AB

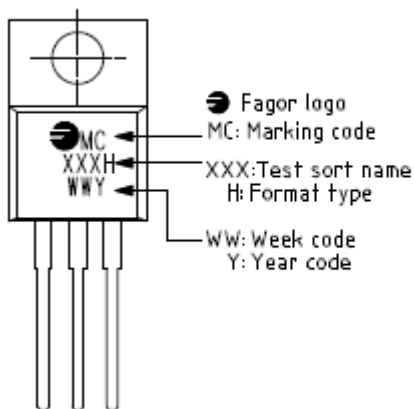

Example

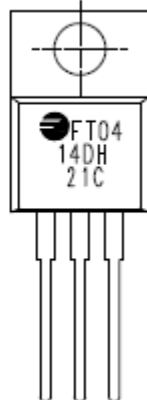

TO-220 AB INSULATED

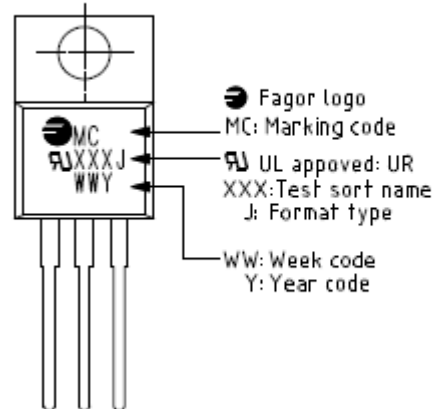

Example

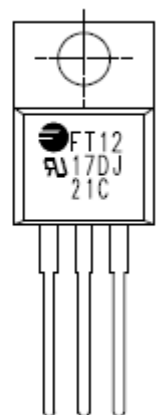

MARKING

Fagor Electrónica Semiconductores

TO-220 F

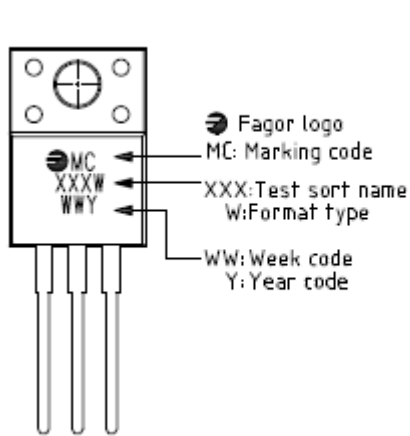

Example

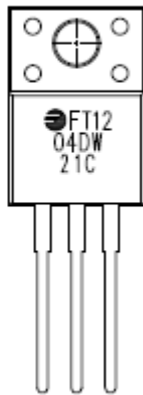

TO-3P FP

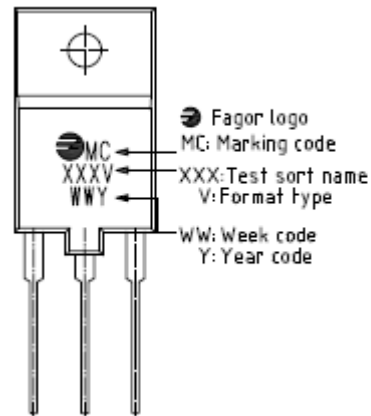

Example

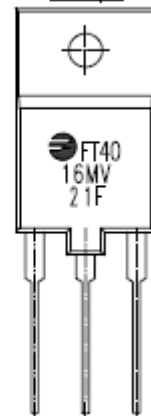

TO-3P INSULATED

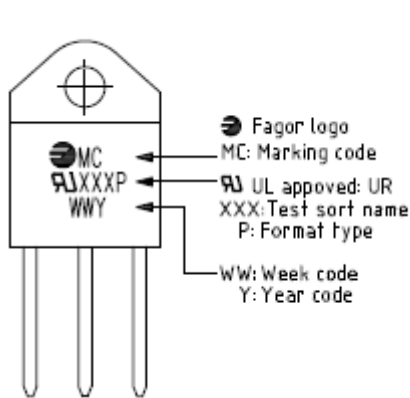

Example

