



Is Now Part of



**ON Semiconductor®**

To learn more about ON Semiconductor, please visit our website at  
[www.onsemi.com](http://www.onsemi.com)

ON Semiconductor and the ON Semiconductor logo are trademarks of Semiconductor Components Industries, LLC dba ON Semiconductor or its subsidiaries in the United States and/or other countries. ON Semiconductor owns the rights to a number of patents, trademarks, copyrights, trade secrets, and other intellectual property. A listing of ON Semiconductor's product/patent coverage may be accessed at [www.onsemi.com/site/pdf/Patent-Marking.pdf](http://www.onsemi.com/site/pdf/Patent-Marking.pdf). ON Semiconductor reserves the right to make changes without further notice to any products herein. ON Semiconductor makes no warranty, representation or guarantee regarding the suitability of its products for any particular purpose, nor does ON Semiconductor assume any liability arising out of the application or use of any product or circuit, and specifically disclaims any and all liability, including without limitation special, consequential or incidental damages. Buyer is responsible for its products and applications using ON Semiconductor products, including compliance with all laws, regulations and safety requirements or standards, regardless of any support or applications information provided by ON Semiconductor. "Typical" parameters which may be provided in ON Semiconductor data sheets and/or specifications can and do vary in different applications and actual performance may vary over time. All operating parameters, including "Typicals" must be validated for each customer application by customer's technical experts. ON Semiconductor does not convey any license under its patent rights nor the rights of others. ON Semiconductor products are not designed, intended, or authorized for use as a critical component in life support systems or any FDA Class 3 medical devices or medical devices with a same or similar classification in a foreign jurisdiction or any devices intended for implantation in the human body. Should Buyer purchase or use ON Semiconductor products for any such unintended or unauthorized application, Buyer shall indemnify and hold ON Semiconductor and its officers, employees, subsidiaries, affiliates, and distributors harmless against all claims, costs, damages, and expenses, and reasonable attorney fees arising out of, directly or indirectly, any claim of personal injury or death associated with such unintended or unauthorized use, even if such claim alleges that ON Semiconductor was negligent regarding the design or manufacture of the part. ON Semiconductor is an Equal Opportunity/Affirmative Action Employer. This literature is subject to all applicable copyright laws and is not for resale in any manner.



## CMOS Linear Applications

PNP and NPN bipolar transistors have been used for many years in "complementary" type of amplifier circuits. Now, with the arrival of CMOS technology, complementary P-channel/N-channel MOS transistors are available in monolithic form. The MM74C04 incorporates a P-channel MOS transistor and an N-channel MOS transistor connected in complementary fashion to function as an inverter. Due to the symmetry of the P- and N-channel transistors, negative feedback around the complementary pair will cause the pair to self bias itself to approximately 1/2 of the supply voltage. Figure 1 shows an idealized voltage transfer characteristic curve of the CMOS inverter connected with negative feedback. Under these conditions the inverter is biased for operation about the midpoint in the linear segment on the steep transition of the voltage transfer characteristics as shown in Figure 1.

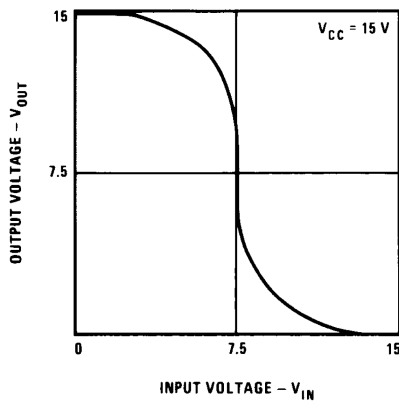

FIGURE 1. Idealized Voltage Transfer Characteristics of an MM74C04 Inverter

Under AC Conditions, a positive going input will cause the output to swing negative and a negative going input will have an inverse effect. Figure 2 shows 1/6 of a MM74C04 inverter package connected as an AC amplifier.

The power supply current is constant during dynamic operation since the inverter is biased for Class A operation. When the input signal swings near the supply, the output signal will become distorted because the P-N channel devices are driven into the non-linear regions of their transfer characteristics. If the input signal approaches the supply voltages, the P- or N-channel transistors become saturated and supply current is reduced to essentially zero and the device behaves like the classical digital inverter.

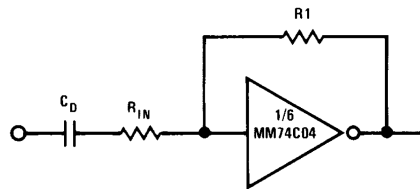

FIGURE 2. A 74CMOS Inverter Biased for Linear Mode Operation

Figure 3 shows typical voltage characteristics of each inverter at several values of the  $V_{CC}$ . The shape of these transfer curves are relatively constant with temperature. Temperature affects for the self-biased inverter with supply voltage is shown in Figure 4. When the amplifier is operating at 3 volts, the supply current changes drastically as a function of supply voltage because the MOS transistors are operating in the proximity of their gate-source threshold voltages.

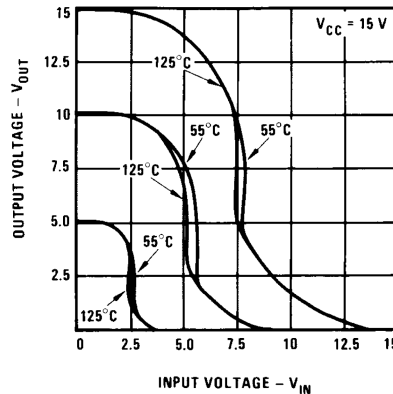
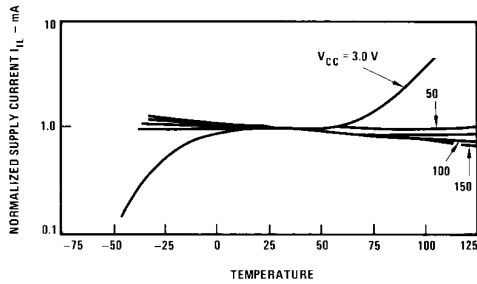
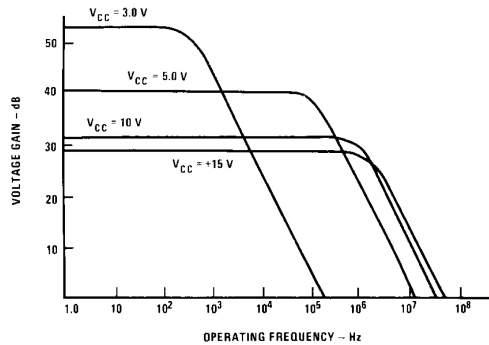

FIGURE 3. Voltage Transfer Characteristics for an Inverter Connected as a Linear Amplifier



**FIGURE 4. Normalized Amplifier Supply Current Versus Ambient Temperature Characteristics**

Figure 5 shows typical curves of voltage gain as a function of operating frequency for various supply voltages. Output voltages can swing within millivolts of the supplies with either a single or a dual supply.

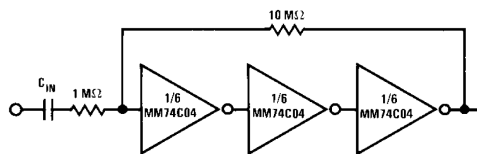

**FIGURE 5. Typical Voltage Gain Versus Frequency Characteristics for Amplifier Shown in Figure 2**

## Applications

### Cascading Amplifiers for Higher Gain

By cascading the basic amplifier block shown in Figure 2 a high gain amplifier can be achieved. The gain will be multiplied by the number of stages used. If more than one inverter is used inside the feedback loop (as in Figure 6) a higher open loop gain is achieved which results in more accurate closed loop gains.



**FIGURE 6. Three CMOS Inverters Used as an X10 AC Amplifier**

### Post Amplifier for Op Amps

A standard operational amplifier used with a CMOS inverter for a Post Amplifier has several advantages. The operational amplifier essentially sees no load condition since the input impedance to the inverter is very high. Secondly, the CMOS inverters will swing to within millivolts of either supply. This gives the designer the advantage of operating the operational amplifier under no load conditions yet having the full supply swing capability on the output. Shown in Figure 7 is the LM4250 micropower Op Amp used with a 74C04 inverter for increased output capability while maintaining the low power advantage of both devices.

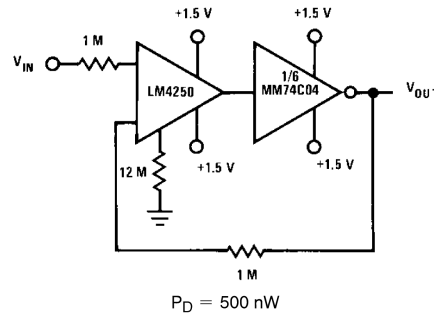

**FIGURE 7. MM74C04 Inverter Used as a Post Amplifier for a Battery Operated Op Amp**

The MM74C04 can also be used with single supply amplifier such as the LM324. With the circuit shown in Figure 8, the open loop gain is approximately 160 dB. The LM324 has 4 amplifiers in a package and the MM74C04 has 6 amplifiers per package.

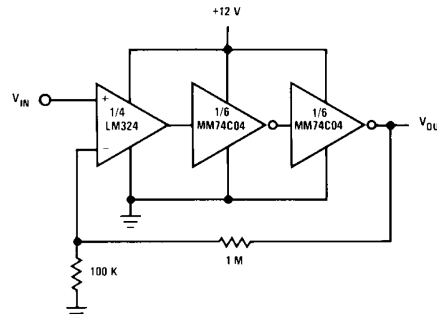
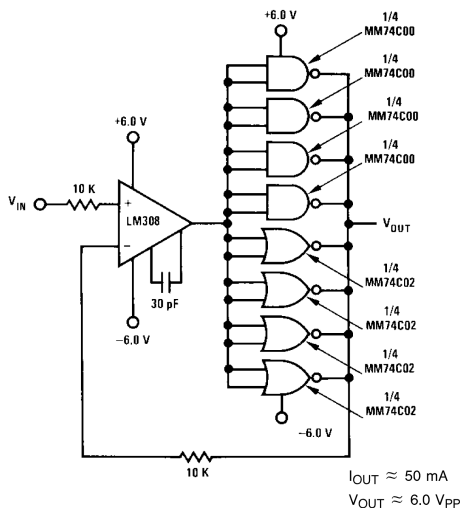

**FIGURE 8. Single Supply Amplifier Using a CMOS Cascade Post Amplifier with the LM324**

**Applications** (Continued)

CMOS inverters can be paralleled for increased power to drive higher current loads. Loads of 5.0 mA per inverter can be expected under AC conditions.

Other 74C devices can be used to provide greater complementary current outputs. The MM74C00 NAND Gate will provide approximately 10 mA from the  $V_{CC}$  supply while the MM74C02 will supply approximately 10 mA from the negative supply. Shown in Figure 9 is an operational amplifier using a CMOS power post amplifier to provide greater than 40 mA complementary currents.



**FIGURE 9. MM74C00 and MM74C02 Used as a Post Amplifier to Provide Increased Current Drive**

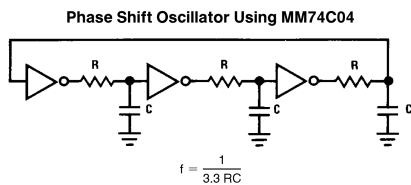

**Integrator Using Any Inverting CMOS Gate**

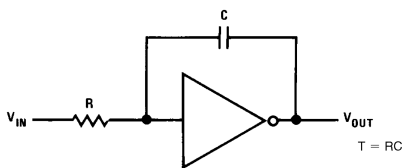

**Square Wave Oscillator**

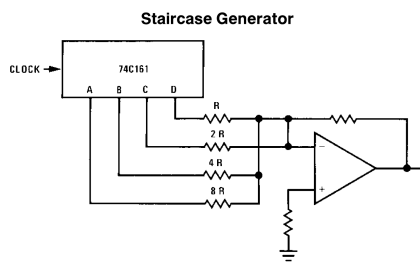
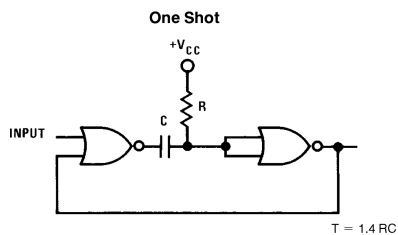
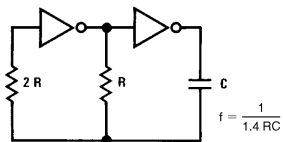

**FIGURE 10. Variety of Circuit Ideas Using CMOS Devices**

## Conclusion

Careful study of CMOS characteristics show that CMOS devices used in a system design can be used for linear building blocks as well as digital blocks.

Utilization of these new devices will decrease package count and reduce supply requirements. The circuit designer now can do both digital and linear designs with the same type of device.

Fairchild does not assume any responsibility for use of any circuitry described, no circuit patent licenses are implied and Fairchild reserves the right at any time without notice to change said circuitry and specifications.

### LIFE SUPPORT POLICY

FAIRCHILD'S PRODUCTS ARE NOT AUTHORIZED FOR USE AS CRITICAL COMPONENTS IN LIFE SUPPORT DEVICES OR SYSTEMS WITHOUT THE EXPRESS WRITTEN APPROVAL OF THE PRESIDENT OF FAIRCHILD SEMICONDUCTOR CORPORATION. As used herein:

1. Life support devices or systems are devices or systems which, (a) are intended for surgical implant into the body, or (b) support or sustain life, and (c) whose failure to perform when properly used in accordance with instructions for use provided in the labeling, can be reasonably expected to result in a significant injury to the user.
2. A critical component in any component of a life support device or system whose failure to perform can be reasonably expected to cause the failure of the life support device or system, or to affect its safety or effectiveness.

[www.fairchildsemi.com](http://www.fairchildsemi.com)

ON Semiconductor and  are trademarks of Semiconductor Components Industries, LLC dba ON Semiconductor or its subsidiaries in the United States and/or other countries. ON Semiconductor owns the rights to a number of patents, trademarks, copyrights, trade secrets, and other intellectual property. A listing of ON Semiconductor's product/patent coverage may be accessed at [www.onsemi.com/site/pdf/Patent-Marking.pdf](http://www.onsemi.com/site/pdf/Patent-Marking.pdf). ON Semiconductor reserves the right to make changes without further notice to any products herein. ON Semiconductor makes no warranty, representation or guarantee regarding the suitability of its products for any particular purpose, nor does ON Semiconductor assume any liability arising out of the application or use of any product or circuit, and specifically disclaims any and all liability, including without limitation special, consequential or incidental damages. Buyer is responsible for its products and applications using ON Semiconductor products, including compliance with all laws, regulations and safety requirements or standards, regardless of any support or applications information provided by ON Semiconductor. "Typical" parameters which may be provided in ON Semiconductor data sheets and/or specifications can and do vary in different applications and actual performance may vary over time. All operating parameters, including "Typicals" must be validated for each customer application by customer's technical experts. ON Semiconductor does not convey any license under its patent rights nor the rights of others. ON Semiconductor products are not designed, intended, or authorized for use as a critical component in life support systems or any FDA Class 3 medical devices or medical devices with a same or similar classification in a foreign jurisdiction or any devices intended for implantation in the human body. Should Buyer purchase or use ON Semiconductor products for any such unintended or unauthorized application, Buyer shall indemnify and hold ON Semiconductor and its officers, employees, subsidiaries, affiliates, and distributors harmless against all claims, costs, damages, and expenses, and reasonable attorney fees arising out of, directly or indirectly, any claim of personal injury or death associated with such unintended or unauthorized use, even if such claim alleges that ON Semiconductor was negligent regarding the design or manufacture of the part. ON Semiconductor is an Equal Opportunity/Affirmative Action Employer. This literature is subject to all applicable copyright laws and is not for resale in any manner.

## PUBLICATION ORDERING INFORMATION

### LITERATURE FULFILLMENT:

Literature Distribution Center for ON Semiconductor  
19521 E. 32nd Pkwy, Aurora, Colorado 80011 USA  
**Phone:** 303-675-2175 or 800-344-3860 Toll Free USA/Canada  
**Fax:** 303-675-2176 or 800-344-3867 Toll Free USA/Canada  
**Email:** [orderlit@onsemi.com](mailto:orderlit@onsemi.com)

**N. American Technical Support:** 800-282-9855 Toll Free  
USA/Canada  
**Europe, Middle East and Africa Technical Support:**  
Phone: 421 33 790 2910  
**Japan Customer Focus Center**  
Phone: 81-3-5817-1050

**ON Semiconductor Website:** [www.onsemi.com](http://www.onsemi.com)  
**Order Literature:** <http://www.onsemi.com/orderlit>  
For additional information, please contact your local  
Sales Representative