



Is Now Part of



ON Semiconductor®

To learn more about ON Semiconductor, please visit our website at
www.onsemi.com

ON Semiconductor and the ON Semiconductor logo are trademarks of Semiconductor Components Industries, LLC dba ON Semiconductor or its subsidiaries in the United States and/or other countries. ON Semiconductor owns the rights to a number of patents, trademarks, copyrights, trade secrets, and other intellectual property. A listing of ON Semiconductor's product/patent coverage may be accessed at www.onsemi.com/site/pdf/Patent-Marking.pdf. ON Semiconductor reserves the right to make changes without further notice to any products herein. ON Semiconductor makes no warranty, representation or guarantee regarding the suitability of its products for any particular purpose, nor does ON Semiconductor assume any liability arising out of the application or use of any product or circuit, and specifically disclaims any and all liability, including without limitation special, consequential or incidental damages. Buyer is responsible for its products and applications using ON Semiconductor products, including compliance with all laws, regulations and safety requirements or standards, regardless of any support or applications information provided by ON Semiconductor. "Typical" parameters which may be provided in ON Semiconductor data sheets and/or specifications can and do vary in different applications and actual performance may vary over time. All operating parameters, including "Typicals" must be validated for each customer application by customer's technical experts. ON Semiconductor does not convey any license under its patent rights nor the rights of others. ON Semiconductor products are not designed, intended, or authorized for use as a critical component in life support systems or any FDA Class 3 medical devices or medical devices with a same or similar classification in a foreign jurisdiction or any devices intended for implantation in the human body. Should Buyer purchase or use ON Semiconductor products for any such unintended or unauthorized application, Buyer shall indemnify and hold ON Semiconductor and its officers, employees, subsidiaries, affiliates, and distributors harmless against all claims, costs, damages, and expenses, and reasonable attorney fees arising out of, directly or indirectly, any claim of personal injury or death associated with such unintended or unauthorized use, even if such claim alleges that ON Semiconductor was negligent regarding the design or manufacture of the part. ON Semiconductor is an Equal Opportunity/Affirmative Action Employer. This literature is subject to all applicable copyright laws and is not for resale in any manner.

A180W, 100KHz Forward Converter Using QFET

by I.S. Yang

Introduction

The inherent performance advantage of power MOSFETs makes their use very attractive in switched mode power supplies. The fundamental advantage of the power MOSFET is the operation at fast switching speeds and high frequencies. Higher operating frequency allows further reduction in the size of the filter and magnetic components. The recent introduction of Fairchild Semiconductor's QFET power MOSFETs provide a significant improvement in the reliability of switching power supplies. This application note illustrates ways in which QFET power MOSFETs may be used in switched mode power supplies. It describes a 100KHz, 180W simple off-line power supply with three regulated DC voltages.

Description of the SMPS

The power supply employs a single ended forward topology. (see Figure 3) The targeted performance figures for the supply are as follows:

Input voltage: 220V AC
Output Voltage and current: $V_{O1} = +5V/20A$
$V_{O2} = +12V/6A$
$V_{O3} = -12V/0.8A$
Full load efficiency: 75% (79% at half load)
Switching frequency: 100KHz
Output Regulation: 5% (1/2 full load to full load)

The control circuit is implemented by the use of the current-mode controller IC, KA3842 which is very popular in controlling power supplies. A single 800V/7A rated power QFET in a TO-220 package is used as the main switching device. The performance of a power supply is dependent on various factors such as layout and transformer construction etc. Because of this the above performance data should be regarded as a guide to what may be achieved.

The stated purpose of this application note is not to offer an optimum design but to provide some guidelines on using QFETs for switched mode power supplies.

Basic Circuit Description

In order to take full advantage of the characteristics of the power MOSFET, it is necessary to review the basic circuit concepts of single ended forward converter. The basic schematic for the operation of a single ended forward converter is shown in Figure 1. The operating waveforms describe the idealized voltage and current across the MOSFET. When the MOSFET turns on, the current is transferred from the primary DC power source through the secondary transformer to the output circuit. During the MOSFET's off period, the magnetizing energy in the primary transformer winding is discharged into the clamp and reset circuits. There are two main techniques, RCD type and reset winding, to properly clamp and reset the forward con-

verter's primary transformer to prevent a potential saturation problem. In this application note a RCD type clamp circuit is used. According to the different values of RCD components, the clamp voltage is developed variably in the primary winding. Usually, high voltage with twice the input DC voltage is used to obtain the maximum 50% duty ratio for resetting the transformer flux during the MOSFET's off period at low input DC voltage and full load. That means the peak voltage of twice the primary DC voltage is developed across the MOSFET during the off period. For a nominal line of 220V AC, the peak voltage could reach to at least 660V. This is the reason for a minimum voltage rating of at least 800V.

Simple equations for selecting power MOSFET are as follows:

$$BV_{dss} \geq V_{in(max)} \frac{1}{1 - D_{max}} + \left\{ \begin{array}{l} \text{leakage} \\ \text{inductance} \\ \text{spike} \end{array} \right\}$$

$$I_{d(max)} \geq \frac{1.2P_o}{\eta V_{in(min)} D_{(max)}}$$

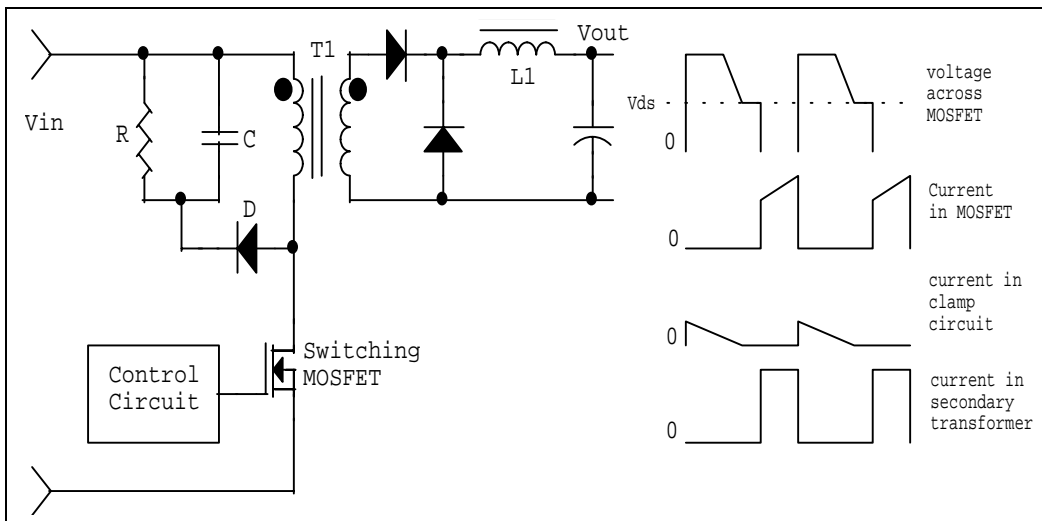

Figure 1. Basic Circuit and Idealized Waveforms

Input Voltage	220V AC line	110V AC line
150W	FQP6N70	FQP6N50, FQP6N60
250W	FQP6N80, FQP7N80	FQP9N50, FQP12N60
300W	FQP7N80, FQP6N90	FQP12N60

Table 1: QFET Selection

QFETs appropriate for the respective power outputs are shown in Table 1. Fairchild Semiconductor's power MOSFET QFETs provide more useful characteristic ratings to the forward converter and other topologies by the reduction of on- resistance, gate charge, and improved reliability.

A RCD Type Clamp Circuit

Usually referred to as the RCD type (Resistor, Capacitor, and Diode), these clamp circuits are used to reset the main transformer to protect from potential saturation problems in this application. In Figure 1, the capacitor charges to the level of voltage of the diode to reset the primary transformer. Then the resistor dissipates the energy stored in the reservoir capacitor. These components develop varying clamp voltages by adjusting the value of the respective components. A high clamp voltage with an amplitude greater than twice the input voltage can deal with a maximum duty cycle beyond 50%. Because of this, the RCD type is particularly useful in a wide range of input supply designs. Clamp circuits have their advantages and disadvantages. The elimination of the reset winding is an obvious advantage in the reduction of transformer cost. The second advantage is that it is useful in a wide range of input power supplies. The main disadvantage of an RCD clamp circuit is the power loss from the resistor, resulting in the decrease of efficiency to some degree. The ground action of this simple clamp circuit is to reset the transformer at the end of the off period regardless of the level of the input voltage by adjusting the voltage across the capacitor with various values of three components. The simple process of acquiring an RCD network is as follows:

The energy stored in the primary transformer per one switching cycle is:

$$P_{ep} = \left[\frac{1}{2} \times L_{mag} \times I_{mag(pk)}^2 + \frac{1}{2} \times L_s \times I_{L(pk)}^2 \right] \times f$$

L_{mag} : the transformer magnetizing inductance

$I_{mag(pk)}$: the peak magnetizing current

L_s : the leakage inductance of the primary transformer

$I_{L(pk)}$: the peak current in the leakage inductance

f : the operating frequency

If the resistor dissipates the above energy, the main transformer is reset.

$$\frac{V_R^2}{R} = P_{ep}$$

V_R : the voltage across the resistor

These RCD type designs often need repetitive work with much of the development effort spent on designing the proper clamp network under all operating conditions. They are less likely to be at optimal efficiency at all lines and loads. Nevertheless, the RCD clamp circuit is very popular because it can make a system fairly efficient and cost-effective.

Designing the Transformer

After reviewing the core information offered by the various core manufacturers, it is obvious that the EER 3542 core adequately fits this application. The full height and width of the bobbin are needed for the required number of turns.

The following equations calculate the minimum number of turns needed by the primary transformer at the lowest DC bus voltage, which is 200V in this case, and the voltage per turn (V_{pt}):

$$\begin{aligned} V_{P(min)} &= \frac{V_{in(min)} \times T_{on(max)}}{\Delta B \times A_e} = \frac{200V \times 5\mu s}{0.2T \times 109mm^2} \\ &= 45 \text{ turns, approx. } 50 \text{ turns} \\ V_{pt} &= \frac{V_{in(min)}}{N} = \frac{200V}{50T} = 4V/turn \end{aligned}$$

When the MOSFET is turned on, the voltage required at the secondary transformer to maintain the output voltage is:

$$V_{\text{sec}} = V_{\text{diode}} + V_{L(\text{on})} + V_{\text{out}}$$

Where V_{diode} is the output rectifier's forward voltage drop and $V_{L(\text{on})}$ is the inductor voltage during the conduction time. As the output current is in continuous-mode operation, the relation between the secondary transformer voltage (V_{sec}) and output voltage is just equal to that of a Buck derived converter (see Figure 1):

$$V_{\text{out}} = D \times V_{\text{sec}} \quad D: \text{Duty Ratio}$$

With a maximum duty cycle of 50%, V_{sec} is equal to $2V_{\text{out}}$. Taking the voltage drop of V_{diode} and $V_{L(\text{on})}$ into consideration, the $V_{\text{sec}}(5\text{V})$ of the 5 V output stage can be then 12V and the $V_{\text{sec}}(12\text{V})$ of the 12V output stage is 26V with a little margin.

The number of turns needed for +5V and +12V secondary by the V_{pt} :

$$N_{\text{sec}(5\text{V})} = \frac{12}{V_{\text{pt}}} = 3 \text{ turns}$$

$$N_{\text{sec}(12\text{V})} = \frac{26}{V_{\text{pt}}} = 6.5 \text{ turns, approx. 7 turns}$$

Four auxiliary windings generate the control IC operating voltage of +16V output. Considering the diode voltage drops, the minimum drop across the inductor is 16V. The physical winding of the transformer is important as the transformer's performance is affected by it. Figure 2 shows the power transformer used in this application.

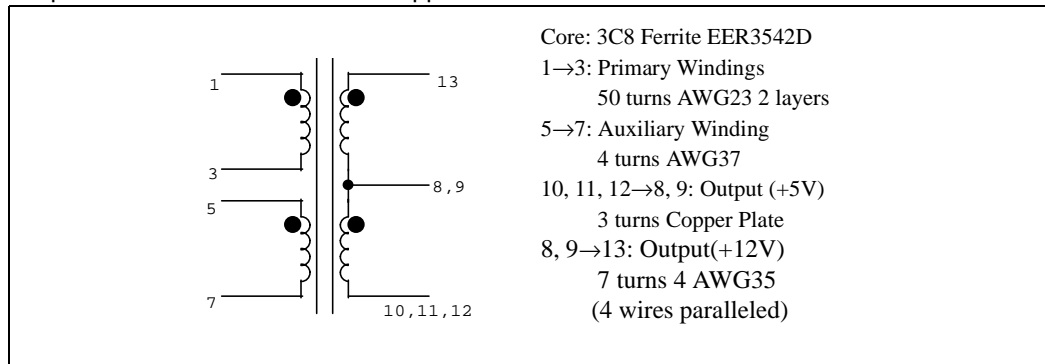

Figure 2. Power Transformer, T1

Performance

The efficiency of the power supply is 79% at half load, and 75% at full load condition (+5V/20A, +12V/6A, -12V/0.8A). The -12V output stage employs the negative fixed voltage regulator (KA7912) featuring output current in excess of 1A for precise output voltage, before the coupled filter inductor (see Figure 3). The power MOSFET QFET FQP7N80, used as the main switching device, offers improved characteristics featuring a smaller gate charge ($Q_g(\text{max})=52\text{nC}$) and lower on-resistance ($R_{\text{ds(on)}}\text{max}=1.5$) than a conventional MOSFET. By taking full advantage of singular well stripe technology, Fairchild Semiconductor's power QFET provides designers with highly effective performance systems. Figure 4(a) shows the waveforms of the gate-to-source [V_{gs}] and drain-to-source voltage [V_{ds}] at half load condition, while figure 4(b) shows the waveforms at full load condition.

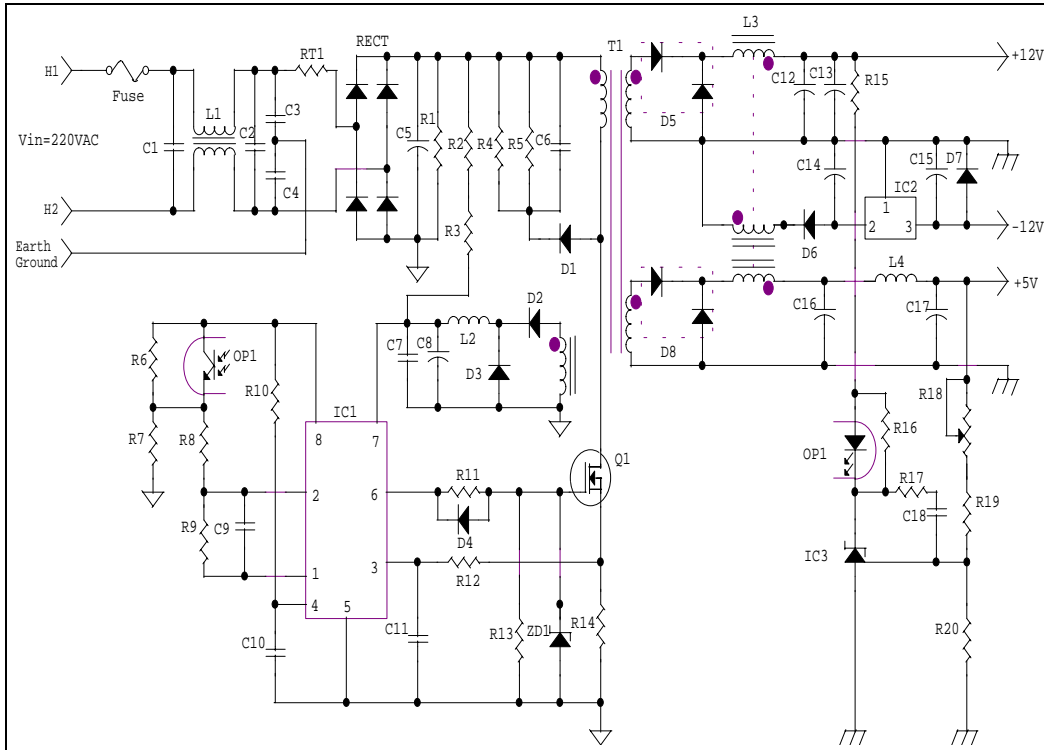

Figure 3. Circuit Diagram of a Forward Converter

As output load increases gradually, the MOSFET conduction time automatically increases from 33% at half load to 38% at full load under the action of a closed-loop regulator circuit, which maintains an essentially constant output voltage.

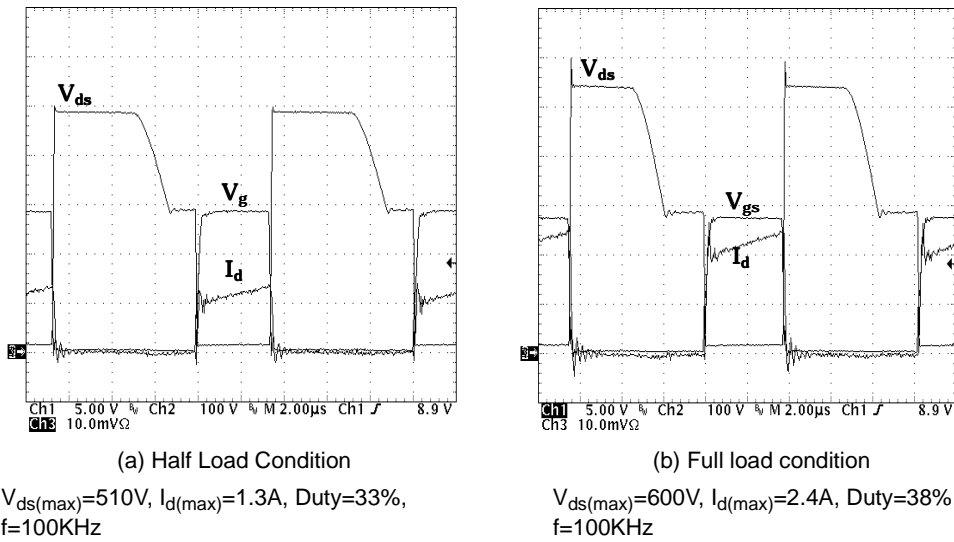

Figure 4. Waveforms of Drain Voltage and Current During Turn-on, 220VAC Line Input

Figure 4(b) shows that at even nominal line input voltage of 220V AC, the peak drain-to-source voltage of the MOSFET is at least 600V. The power QFET FQP7N80 is adequate for this switching condition.

Part	Value	Part	Value	Part	Value
Q1	FQP7N80	R16	10K Ω (1/4W)	C15	470 μ F (25V)
IC1	KA3842B	R17	1K Ω (1/4W)	C16	3300 μ F (10V)
IC2	KA7912	VR18	1K Ω (1/4W)	C17	3300 μ F (10V)
IC3	KA431	R19	2.2K Ω (1/4W)	C18	104
R1	220K Ω (1W)	R20	2.2K Ω (1/4W)	OP	PC817
R2	150K Ω (1W)	C1	0.47 μ F	T1	Transformer
R3	150K Ω (1W)	C2	0.22 μ F	L1	Line Filter
R4	150K Ω (1W)	C3	0.33 μ F	L2	3 μ H
R5	150K Ω (1W)	C4	0.33 μ F	L3	Coupled Inductor
R6	12K Ω (1/4W)	C5	220 μ F	L4	10 μ H
R7	2.7K Ω (1/4W)	C6	223	ZD1	1N4749
R8	100K Ω (1/4W)	C7	102	D1~3	1N4937
R9	100K Ω (1/4W)	C8	47 μ F	D4	1N4148
R10	7K Ω (1/4W)	C9	561	D5	FYPF1010DN(100V/10A)
R11	33 Ω (1/4W)	C10	222	D6	FYAF3040DN(40V/30A)
R12	1K Ω (1/4W)	C11	471	D7	1N4937
R13	10K Ω (1/4W)	C12	2200 μ F (25V)	D8	FR304
R14	0.3 Ω (1W)	C13	2200 μ F (25V)	Fuse	3A / 250VAC
R15	1K Ω (1/4W)	C14	470 μ F (25V)		

Summary

This application note describes ways in which the Fairchild Semiconductor power QFET may be used in switched mode power supplies. An illustration of this application is a 180W, 100kHz forward type power supply using a single 800V rated QFET (FQP7N80) to provide regulated three output voltages. Because the performance of a power supply of this type depends on various factors such as PCB layout, transformer construction, and switching device etc., the stated performance results have to be regarded as benchmarks and not absolutes. The other series of high voltage rated QFETs offered by Fairchild Semiconductor (700, 800, and 900V ratings) allows designers to improve the performance of a switched mode power supply by significantly reducing gate charge and on-resistance.

References

1. Switch Mode Power Supply, Hee Jun Kim, Sung An Dang, 1993
2. Practical Switching Power Supply Design, Marty Brown, Academic Press, San Diego, CA.
3. Power Supply Cookbook, Marty Brown, Butterworth Heinemann, 1994

TRADEMARKS

The following are registered and unregistered trademarks Fairchild Semiconductor owns or is authorized to use and is not intended to be an exhaustive list of all such trademarks.

ACEx™	HiSeC™	SuperSOT™-8
Bottomless™	ISOPLANAR™	SyncFET™
CoolFET™	MICROWIRE™	TinyLogic™
CROSSVOLT™	POP™	UHC™
E ² CMOS™	PowerTrench®	VCX™
FACT™	QFET™	
FACT Quiet Series™	QS™	
FAST®	Quiet Series™	
FASTr™	SuperSOT™-3	
GTO™	SuperSOT™-6	

DISCLAIMER

FAIRCHILD SEMICONDUCTOR RESERVES THE RIGHT TO MAKE CHANGES WITHOUT FURTHER NOTICE TO ANY PRODUCTS HEREIN TO IMPROVE RELIABILITY, FUNCTION OR DESIGN. FAIRCHILD DOES NOT ASSUME ANY LIABILITY ARISING OUT OF THE APPLICATION OR USE OF ANY PRODUCT OR CIRCUIT DESCRIBED HEREIN; NEITHER DOES IT CONVEY ANY LICENSE UNDER ITS PATENT RIGHTS, NOR THE RIGHTS OF OTHERS.

LIFE SUPPORT POLICY

FAIRCHILD'S PRODUCTS ARE NOT AUTHORIZED FOR USE AS CRITICAL COMPONENTS IN LIFE SUPPORT DEVICES OR SYSTEMS WITHOUT THE EXPRESS WRITTEN APPROVAL OF FAIRCHILD SEMICONDUCTOR INTERNATIONAL.

As used herein:

1. Life support devices or systems are devices or which, (a) are intended for surgical implant into the body, or (b) support or sustain life, or (c) whose failure to perform when properly used in accordance with instructions for use provided in the labeling, can be reasonably expected to result in significant injury to the user.
2. A critical component is any component of a life support device or system whose failure to perform can be reasonably expected to cause the failure of the life support device or system, or to affect its safety or effectiveness.

PRODUCT STATUS DEFINITIONS

Definition of Terms

Datasheet Identification	Product Status	Definition
Advance Information	Formative or In Design	This datasheet contains the design specifications for product development. Specifications may change in any manner without notice.
Preliminary	First Production	This datasheet contains preliminary data, and supplementary data will be published at a later date. Fairchild Semiconductor reserves the right to make changes at any time without notice in order to improve design.
No Identification Needed	Full Production	This datasheet contains final specifications. Fairchild Semiconductor reserves the right to make changes at any time without notice in order to improve design.
Obsolete	Not In Production	This datasheet contains specifications on a product that has been discontinued by Fairchild semiconductor. The datasheet is printed for reference information only.

ON Semiconductor and  are trademarks of Semiconductor Components Industries, LLC dba ON Semiconductor or its subsidiaries in the United States and/or other countries. ON Semiconductor owns the rights to a number of patents, trademarks, copyrights, trade secrets, and other intellectual property. A listing of ON Semiconductor's product/patent coverage may be accessed at www.onsemi.com/site/pdf/Patent-Marking.pdf. ON Semiconductor reserves the right to make changes without further notice to any products herein. ON Semiconductor makes no warranty, representation or guarantee regarding the suitability of its products for any particular purpose, nor does ON Semiconductor assume any liability arising out of the application or use of any product or circuit, and specifically disclaims any and all liability, including without limitation special, consequential or incidental damages. Buyer is responsible for its products and applications using ON Semiconductor products, including compliance with all laws, regulations and safety requirements or standards, regardless of any support or applications information provided by ON Semiconductor. "Typical" parameters which may be provided in ON Semiconductor data sheets and/or specifications can and do vary in different applications and actual performance may vary over time. All operating parameters, including "Typicals" must be validated for each customer application by customer's technical experts. ON Semiconductor does not convey any license under its patent rights nor the rights of others. ON Semiconductor products are not designed, intended, or authorized for use as a critical component in life support systems or any FDA Class 3 medical devices or medical devices with a same or similar classification in a foreign jurisdiction or any devices intended for implantation in the human body. Should Buyer purchase or use ON Semiconductor products for any such unintended or unauthorized application, Buyer shall indemnify and hold ON Semiconductor and its officers, employees, subsidiaries, affiliates, and distributors harmless against all claims, costs, damages, and expenses, and reasonable attorney fees arising out of, directly or indirectly, any claim of personal injury or death associated with such unintended or unauthorized use, even if such claim alleges that ON Semiconductor was negligent regarding the design or manufacture of the part. ON Semiconductor is an Equal Opportunity/Affirmative Action Employer. This literature is subject to all applicable copyright laws and is not for resale in any manner.

PUBLICATION ORDERING INFORMATION

LITERATURE FULFILLMENT:

Literature Distribution Center for ON Semiconductor
19521 E. 32nd Pkwy, Aurora, Colorado 80011 USA
Phone: 303-675-2175 or 800-344-3860 Toll Free USA/Canada
Fax: 303-675-2176 or 800-344-3867 Toll Free USA/Canada
Email: orderlit@onsemi.com

N. American Technical Support: 800-282-9855 Toll Free
USA/Canada
Europe, Middle East and Africa Technical Support:
Phone: 421 33 790 2910
Japan Customer Focus Center
Phone: 81-3-5817-1050

ON Semiconductor Website: www.onsemi.com
Order Literature: <http://www.onsemi.com/orderlit>
For additional information, please contact your local
Sales Representative