



Is Now Part of



ON Semiconductor®

To learn more about ON Semiconductor, please visit our website at
www.onsemi.com

ON Semiconductor and the ON Semiconductor logo are trademarks of Semiconductor Components Industries, LLC dba ON Semiconductor or its subsidiaries in the United States and/or other countries. ON Semiconductor owns the rights to a number of patents, trademarks, copyrights, trade secrets, and other intellectual property. A listing of ON Semiconductor's product/patent coverage may be accessed at www.onsemi.com/site/pdf/Patent-Marking.pdf. ON Semiconductor reserves the right to make changes without further notice to any products herein. ON Semiconductor makes no warranty, representation or guarantee regarding the suitability of its products for any particular purpose, nor does ON Semiconductor assume any liability arising out of the application or use of any product or circuit, and specifically disclaims any and all liability, including without limitation special, consequential or incidental damages. Buyer is responsible for its products and applications using ON Semiconductor products, including compliance with all laws, regulations and safety requirements or standards, regardless of any support or applications information provided by ON Semiconductor. "Typical" parameters which may be provided in ON Semiconductor data sheets and/or specifications can and do vary in different applications and actual performance may vary over time. All operating parameters, including "Typicals" must be validated for each customer application by customer's technical experts. ON Semiconductor does not convey any license under its patent rights nor the rights of others. ON Semiconductor products are not designed, intended, or authorized for use as a critical component in life support systems or any FDA Class 3 medical devices or medical devices with a same or similar classification in a foreign jurisdiction or any devices intended for implantation in the human body. Should Buyer purchase or use ON Semiconductor products for any such unintended or unauthorized application, Buyer shall indemnify and hold ON Semiconductor and its officers, employees, subsidiaries, affiliates, and distributors harmless against all claims, costs, damages, and expenses, and reasonable attorney fees arising out of, directly or indirectly, any claim of personal injury or death associated with such unintended or unauthorized use, even if such claim alleges that ON Semiconductor was negligent regarding the design or manufacture of the part. ON Semiconductor is an Equal Opportunity/Affirmative Action Employer. This literature is subject to all applicable copyright laws and is not for resale in any manner.

System Clock Distribution Example Using LVDS

Abstract

Noise within high-speed digital systems especially when dealing with critical signals such as the ones in clock distribution circuits can be a concern for designers. Running single-ended clock lines over long traces across a printed circuit board can introduce unwanted noise such as crosstalk that ultimately affects the performance and reliability of a digital system. This paper will discuss the benefits of using Low Voltage Differential Signaling (LVDS) for clock distribution and how this signaling technique addresses this problem. An application example will also be provided.

Why Use Differential Signaling?

System designers should consider using differential signaling circuits if there is a concern of introducing noise from clock line(s) across the circuit board and the requirement for critical clock line with a high level of noise immunity from the other adjacent PCB traces.

Differential signaling addresses both of these design concerns as the signaling technique uses traces between a driver and receiver with one trace carrying a positive signal

and the other carrying the negative signal equal and opposite in polarity. With this technique the return current through the ground system cancels assuming they are exact opposites of each other. The return current from the positive signal is (+i) which is equal to the return current of the negative signal (-i) and their SUM is zero.

Benefits of Using LVDS

A differential receiver is designed to respond to the difference between a pair of inputs and have a common mode rejection capability. That means any noise such as EMI or crosstalk that is common to both traces will be rejected by the receiver. To illustrate this feature reference Figure 1 which is a scope capture of Fairchild's FIN1018 single bit Low Voltage Differential Signaling (LVDS) receiver. The differential signals driving 6-inch microstrip lines with $\sim 400\text{mV}$ of noise injected equally on both the R- and R+ inputs of the FIN1018 receiver. Note the TTL output of the receiver remains in its current low state simply ignoring the noise excursions on its inputs and toggles only after the differential signals cross over. This common-mode noise rejection also applies to sources such as power supply variations, substrate noise, and ground bounce.

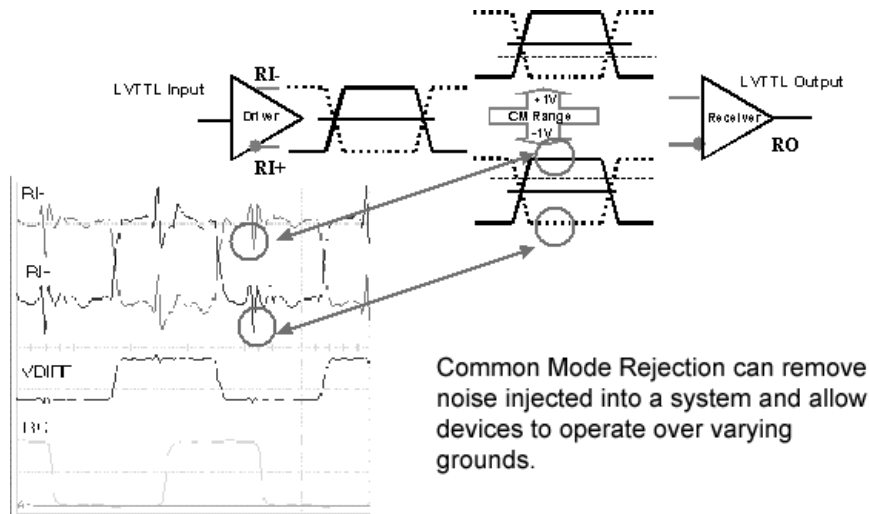

FIGURE 1. LVDS Common Noise Rejection Feature

Clock Distribution Application Example

In this particular application, differential lines on CLKA1 are used simply because the designer does not want to intro-

duce the noise of a 133 MHz clock signal across the board. In addition, because of the critical nature of the clock line, the designer also does not want noise to be injected into the CLKA1 clock line.

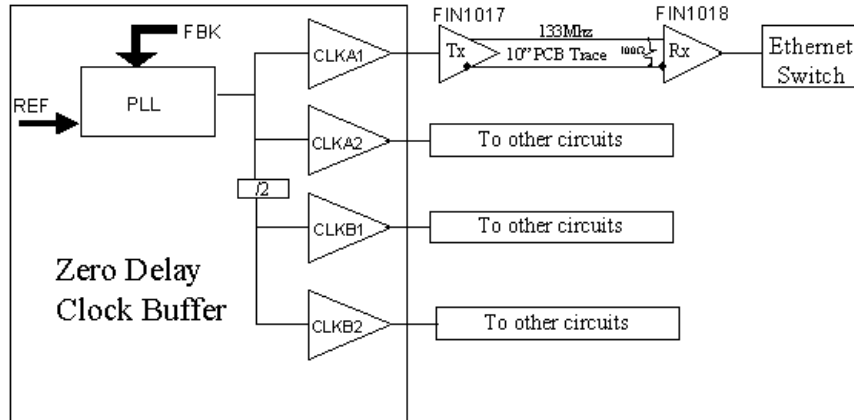

FIGURE 2. Block Diagram of a Clock Distribution Circuit using LVDS

Simulation Results

The question of whether or not the differential link between the clock buffer and the Ethernet switch will work in this particular application is answered below. Simulation of the

point-to-point link with a 10" PCB trace a 133 MHz frequency was conducted and the results were as shown in Figure 3.

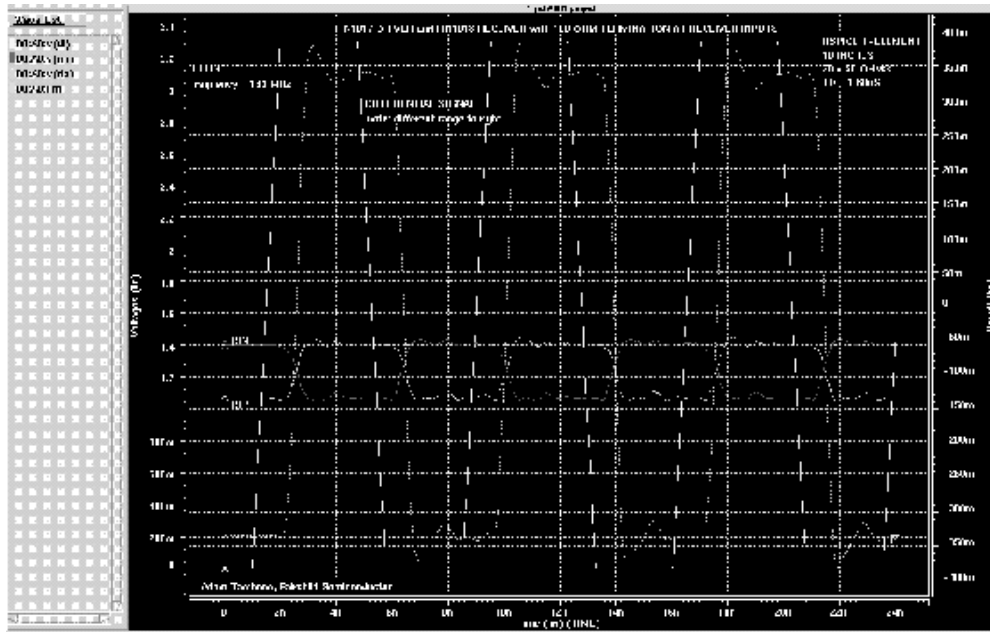

FIGURE 3. Simulation Results of FIN107 Transmitter and FIN1018 Receiver

Yellow Signal = TTL Input @ 133MHz with a 1ns edge
 Red Signal = R_{in} - Single Ended Signal (-1.05V)

Peach Signal = R_{in} + Single Ended Signal (-1.4V)
 Blue Signal = Differential Signal (-680mV)

Summary and Conclusions

LVDS differential lines have equal but opposite currents. When the fields created by these odd-mode signals are closely coupled, they will cancel each other and reduce interference with adjacent PCB traces. Because of this it is important to maintain a balanced and closely coupled differential transmission path to reduce EMI emissions. LVDS signals also have the advantage of tolerating interference from outside sources such as inductive radiation from electric motors or crosstalk from neighboring transmission lines. System designers who need to move high speed clock signals across cable or PCB with minimal EMI and a high level of noise immunity can benefit from LVDS technology.

Fairchild does not assume any responsibility for use of any circuitry described, no circuit patent licenses are implied and Fairchild reserves the right at any time without notice to change said circuitry and specifications.

LIFE SUPPORT POLICY

FAIRCHILD'S PRODUCTS ARE NOT AUTHORIZED FOR USE AS CRITICAL COMPONENTS IN LIFE SUPPORT DEVICES OR SYSTEMS WITHOUT THE EXPRESS WRITTEN APPROVAL OF THE PRESIDENT OF FAIRCHILD SEMICONDUCTOR CORPORATION. As used herein:

1. Life support devices or systems are devices or systems which, (a) are intended for surgical implant into the body, or (b) support or sustain life, and (c) whose failure to perform when properly used in accordance with instructions for use provided in the labeling, can be reasonably expected to result in a significant injury to the user.
2. A critical component in any component of a life support device or system whose failure to perform can be reasonably expected to cause the failure of the life support device or system, or to affect its safety or effectiveness.

www.fairchildsemi.com

ON Semiconductor and  are trademarks of Semiconductor Components Industries, LLC dba ON Semiconductor or its subsidiaries in the United States and/or other countries. ON Semiconductor owns the rights to a number of patents, trademarks, copyrights, trade secrets, and other intellectual property. A listing of ON Semiconductor's product/patent coverage may be accessed at www.onsemi.com/site/pdf/Patent-Marking.pdf. ON Semiconductor reserves the right to make changes without further notice to any products herein. ON Semiconductor makes no warranty, representation or guarantee regarding the suitability of its products for any particular purpose, nor does ON Semiconductor assume any liability arising out of the application or use of any product or circuit, and specifically disclaims any and all liability, including without limitation special, consequential or incidental damages. Buyer is responsible for its products and applications using ON Semiconductor products, including compliance with all laws, regulations and safety requirements or standards, regardless of any support or applications information provided by ON Semiconductor. "Typical" parameters which may be provided in ON Semiconductor data sheets and/or specifications can and do vary in different applications and actual performance may vary over time. All operating parameters, including "Typicals" must be validated for each customer application by customer's technical experts. ON Semiconductor does not convey any license under its patent rights nor the rights of others. ON Semiconductor products are not designed, intended, or authorized for use as a critical component in life support systems or any FDA Class 3 medical devices or medical devices with a same or similar classification in a foreign jurisdiction or any devices intended for implantation in the human body. Should Buyer purchase or use ON Semiconductor products for any such unintended or unauthorized application, Buyer shall indemnify and hold ON Semiconductor and its officers, employees, subsidiaries, affiliates, and distributors harmless against all claims, costs, damages, and expenses, and reasonable attorney fees arising out of, directly or indirectly, any claim of personal injury or death associated with such unintended or unauthorized use, even if such claim alleges that ON Semiconductor was negligent regarding the design or manufacture of the part. ON Semiconductor is an Equal Opportunity/Affirmative Action Employer. This literature is subject to all applicable copyright laws and is not for resale in any manner.

PUBLICATION ORDERING INFORMATION

LITERATURE FULFILLMENT:

Literature Distribution Center for ON Semiconductor
19521 E. 32nd Pkwy, Aurora, Colorado 80011 USA
Phone: 303-675-2175 or 800-344-3860 Toll Free USA/Canada
Fax: 303-675-2176 or 800-344-3867 Toll Free USA/Canada
Email: orderlit@onsemi.com

N. American Technical Support: 800-282-9855 Toll Free
USA/Canada
Europe, Middle East and Africa Technical Support:
Phone: 421 33 790 2910
Japan Customer Focus Center
Phone: 81-3-5817-1050

ON Semiconductor Website: www.onsemi.com
Order Literature: <http://www.onsemi.com/orderlit>
For additional information, please contact your local
Sales Representative