



Is Now Part of



**ON Semiconductor®**

To learn more about ON Semiconductor, please visit our website at  
[www.onsemi.com](http://www.onsemi.com)

ON Semiconductor and the ON Semiconductor logo are trademarks of Semiconductor Components Industries, LLC dba ON Semiconductor or its subsidiaries in the United States and/or other countries. ON Semiconductor owns the rights to a number of patents, trademarks, copyrights, trade secrets, and other intellectual property. A listing of ON Semiconductor's product/patent coverage may be accessed at [www.onsemi.com/site/pdf/Patent-Marking.pdf](http://www.onsemi.com/site/pdf/Patent-Marking.pdf). ON Semiconductor reserves the right to make changes without further notice to any products herein. ON Semiconductor makes no warranty, representation or guarantee regarding the suitability of its products for any particular purpose, nor does ON Semiconductor assume any liability arising out of the application or use of any product or circuit, and specifically disclaims any and all liability, including without limitation special, consequential or incidental damages. Buyer is responsible for its products and applications using ON Semiconductor products, including compliance with all laws, regulations and safety requirements or standards, regardless of any support or applications information provided by ON Semiconductor. "Typical" parameters which may be provided in ON Semiconductor data sheets and/or specifications can and do vary in different applications and actual performance may vary over time. All operating parameters, including "Typicals" must be validated for each customer application by customer's technical experts. ON Semiconductor does not convey any license under its patent rights nor the rights of others. ON Semiconductor products are not designed, intended, or authorized for use as a critical component in life support systems or any FDA Class 3 medical devices or medical devices with a same or similar classification in a foreign jurisdiction or any devices intended for implantation in the human body. Should Buyer purchase or use ON Semiconductor products for any such unintended or unauthorized application, Buyer shall indemnify and hold ON Semiconductor and its officers, employees, subsidiaries, affiliates, and distributors harmless against all claims, costs, damages, and expenses, and reasonable attorney fees arising out of, directly or indirectly, any claim of personal injury or death associated with such unintended or unauthorized use, even if such claim alleges that ON Semiconductor was negligent regarding the design or manufacture of the part. ON Semiconductor is an Equal Opportunity/Affirmative Action Employer. This literature is subject to all applicable copyright laws and is not for resale in any manner.

## LVDS Receiver Failsafe Biasing Networks

### Abstract

Failsafe biasing of an LVDS data line receiver establishes a known state under certain fault conditions. Typically these devices are designed with integrated failsafe biasing resistors. This paper will discuss how to add additional external failsafe biasing resistor networks to increase noise immunity in a system and improve the reliability of failsafe operation within a specific application. An application example will be discussed and calculations for resistor values will also be provided.

### External “Assist” Failsafe Resistors

Certain applications (especially noisy environments) may warrant the need for additional failsafe protection. Adding external failsafe resistors may be justified to create a larger noise margin beyond what is provided by the receiver. Selecting external failsafe resistors can be done to protect against differential noise and have minimal impact on the signal integrity of the LVDS signal. Additional failsafe current will tend to “unbalance” the symmetry of the LVDS signal which should not be an issue at low data rates, however could be aggravated at higher data rates.

### What Resistor Values Should Be Used?

For Fairchild LVDS receivers designed with an internal failsafe bias, they typically will have an internal bias voltage of  $\approx 20$  to  $35\text{mV}$  (Figure 1). In a cable application where the receiver will not always be driven by the transmitter and there is a potential for the presence of more than  $20\text{mV}$  of

differential noise on the receiver inputs, additional failsafe resistors should be considered. The resistor values should be specified to overcome the differential noise and have minimal impact on the driver current. Figure 1 illustrates a typical differential input voltage versus the logic output state of the receiver.

The amount of differential noise anticipated should be measured and resistor values chosen to overcome this noise. The VFSB is the offset voltage is generated across the  $R_t$  resistor and the external resistor values should be enough to overcome the differential noise. Making VFSB too large will counter with the driver loop current impacting the signal integrity of the signal. Note using shielded cable can reduce differential noise.

Once the amount of differential noise at the receiver input has been determined (under worst case conditions), the following formulas are provided to assist the designer in calculating the resistor values.

$$V_{FSB} = R_{pu} / (R_{pu} + R_t + R_{pd}) * V_{CC}$$

$$I_{FSB} = V_{CC} / (R_{pu} + R_t + R_{pd})$$

$(I_{FSB} < 0.1 * I_{LOOP})$

$$V_{CM} = (R_{up} + R_t / 2) / (R_{pu} + R_t + R_{pd}) * V_{CC}$$

$(\text{Ideal } V_{CM} \approx 1.2V)$

$$R_t = (R_t * (R_{pu} + R_{pd})) / (R_{pu} + R_t + R_{pd})$$

$(\text{match } R_t \text{ to } Z_{ODIFF})$

The external failsafe “Assist” resistors may change the termination resistance, thus adjust the  $R_t$  value to match within 10% of the characteristic impedance of the transmission line.

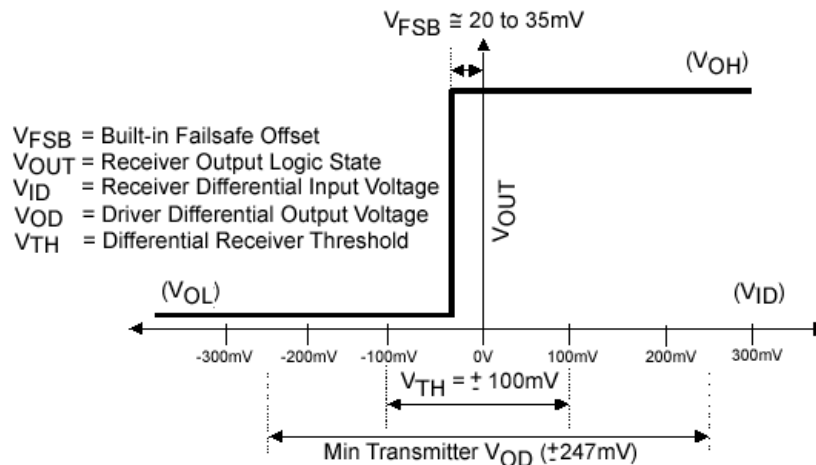

FIGURE 1. Differential Input Voltage versus Receiver Output Voltage

What Resistor Values Should Be Used? (Continued)

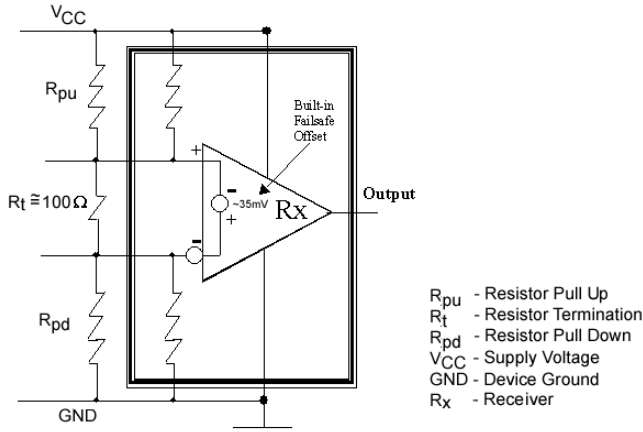

FIGURE 2. Simplified Schematic of Internal Failsafe Circuitry with External "Assist" Failsafe Resistors

Point-to-Point Application Example

System problems can impact proper "Failsafe" operation with LVDS receivers in an application involving communication between equipment racks within the same cabinet typically found in telecom equipment. Potentially receiver outputs will not assert "failsafe" (Logic High) under specific failsafe conditions within a system environment due to the presence of system noise or other circuitry (such as ESD protection diodes) which could impede the effectiveness of the integrated failsafe feature.

Failsafe circuitry internal to the receiver is designed to source/sink a small amount of current, providing failsafe protection for floating receiver inputs, shorted inputs and terminated inputs. However, an application environment and certain conditions potentially create differential noise that causes the receiver to oscillate and not maintain a known failsafe state. External failsafe resistors may be needed to increase or improve noise margins to insure reliable failsafe operation under all fault conditions. Refer to Figure 3 as an example of an external failsafe bias resistor network.

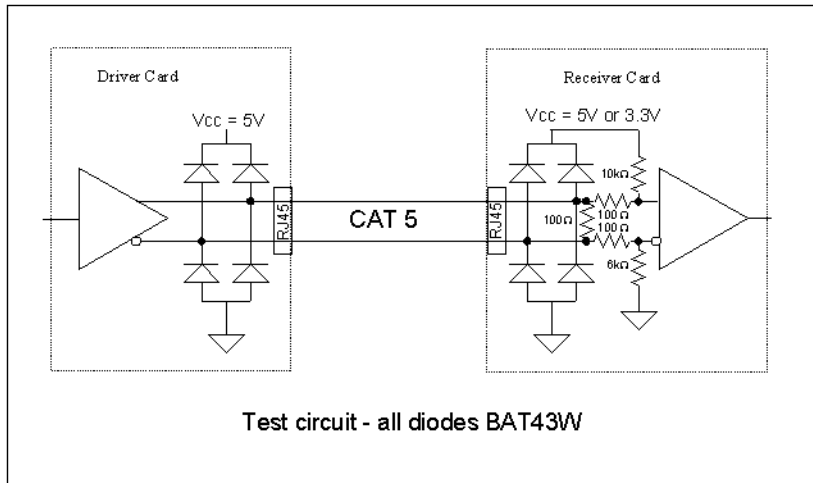

FIGURE 3. Point-to-Point Circuit Application with External Failsafe Resistors and ESD Protection Diodes

## Worse Case Failsafe Conditions

1. Reviewing the circuit in Figure 1, with the driver card powered down ( $V_{CC} = 0V$ ), the ESD protection diode network on the driver card is forward biased. This results in a clamping action of the diodes providing an alternate current path reducing the offset voltage created across the termination. The diodes forward bias causing an approximate worst case clamping of the line at  $\approx 0.3V$  with respect to ground.
2. Series resistors  $R_{sp}$  and  $R_{sm}$  work to counter the effects of the clamping action of the diodes providing additional failsafe bias voltage enabling the receiver to assert a logic high on the output.

3. The suggested resistor network should provide reliable failsafe operation and improved differential noise immunity during a failsafe event.
4. The additional resistor network has been confirmed to have no impact on the signal integrity in our lab setup.

For certain cable point-to-point applications where data rates are in the low MHz range, additional failsafe protection may be needed to improve noise margins and increase the reliability of failsafe operation. The following section discusses and illustrates resistor networks that could be considered for additional failsafe bias resistors yielding increased noise margins.

## Suggested Failsafe Resistor Values for FIN1032

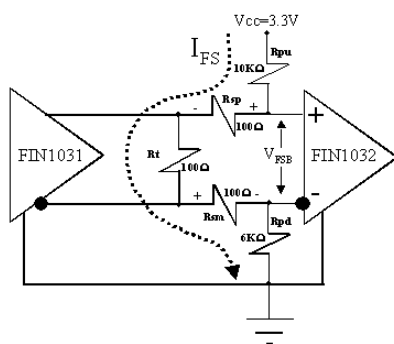

$R_{pu}$	Resistor Pull Up
$R_{sp}$	Resistor Series Plus
$R_t$	Resistor Termination
$R_{sm}$	Resistor Series Minus
$R_{pd}$	Resistor Pull Down
$I_{FS}$	Failsafe Bias Current
$V_{FSB}$	Failsafe Bias Voltage
$V_{CM}$	Common Mode Voltage

### FIN1032 F/S Bias Voltage and Current Calculations

#### With $R_{sp}$ & $R_{sm}$ Resistors

$$I_{FS} \cong 3.3V/16.3K\Omega = 0.202mA$$

$$V_{CM} \cong 0.2mA * 6.15K\Omega \cong 1.23V$$

$$V_{FSB} \cong I_{FS} * 300\Omega \cong 60mV$$

#### Without $R_{sp}$ & $R_{sm}$ Resistors

$$I_{FS} \cong 3.3V/16.2K\Omega = 0.205mA$$

$$V_{CM} \cong 0.205mA * 6.05K\Omega \cong 1.24V$$

$$V_{FSB} \cong I_{FS} * 100\Omega \cong 21mV$$

**Note:** An additional failsafe bias voltage of  $\approx 40mV$  can be attained with the series resistors.

## Suggested Failsafe Resistor Values for FIN1532

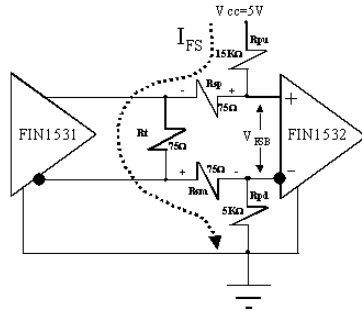

$R_{pu}$	Resistor Pull Up
$R_{sp}$	Resistor Series Plus
$R_t$	Resistor Termination
$R_{sm}$	Resistor Series Minus
$R_{pd}$	Resistor Pull Down
$I_{FS}$	Failsafe Bias Current
$V_{FSB}$	Failsafe Bias Voltage
$V_{CM}$	Common Mode Voltage

### FIN1532 F/S Bias Voltage and Current Calculations

#### With $R_{sp}$ & $R_{sm}$ Resistors

$$I_{FS} \cong 5V/20.25K\Omega = 0.25mA$$

$$V_{CM} \cong 0.25mA * 5.125K\Omega \cong 1.26V$$

$$V_{FSB} \cong I_{FS} * 250\Omega \cong 62mV$$

#### Without $R_{sp}$ & $R_{sm}$ Resistors

$$I_{FS} \cong 5V/20.1K\Omega = 0.249mA$$

$$V_{CM} \cong 0.249mA * 5.050K\Omega \cong 1.26V$$

$$V_{FSB} \cong I_{FS} * 100\Omega \cong 25mV$$

Note: An additional failsafe bias voltage of  $\cong 40mV$  can be attained with the series resistors.

## Summary and Conclusions

LVDS translators are supplied with internal failsafe bias protection. Depending on the system noise environment, it may be necessary to implement an external FS bias resistor network to insure reliable failsafe operation. Other circuitry in a system such as ESD protection networks may impede or counter the effectiveness of the integrated receiver failsafe bias circuit. This paper provided an example of a system that had ESD diode networks employed on the driver and receiver cards. The specific application environment and failsafe requirements will ultimately dictate the optimum failsafe solution.

Fairchild does not assume any responsibility for use of any circuitry described, no circuit patent licenses are implied and Fairchild reserves the right at any time without notice to change said circuitry and specifications.

### LIFE SUPPORT POLICY

FAIRCHILD'S PRODUCTS ARE NOT AUTHORIZED FOR USE AS CRITICAL COMPONENTS IN LIFE SUPPORT DEVICES OR SYSTEMS WITHOUT THE EXPRESS WRITTEN APPROVAL OF THE PRESIDENT OF FAIRCHILD SEMICONDUCTOR CORPORATION. As used herein:

1. Life support devices or systems are devices or systems which, (a) are intended for surgical implant into the body, or (b) support or sustain life, and (c) whose failure to perform when properly used in accordance with instructions for use provided in the labeling, can be reasonably expected to result in a significant injury to the user.
2. A critical component in any component of a life support device or system whose failure to perform can be reasonably expected to cause the failure of the life support device or system, or to affect its safety or effectiveness.

[www.fairchildsemi.com](http://www.fairchildsemi.com)

ON Semiconductor and  are trademarks of Semiconductor Components Industries, LLC dba ON Semiconductor or its subsidiaries in the United States and/or other countries. ON Semiconductor owns the rights to a number of patents, trademarks, copyrights, trade secrets, and other intellectual property. A listing of ON Semiconductor's product/patent coverage may be accessed at [www.onsemi.com/site/pdf/Patent-Marking.pdf](http://www.onsemi.com/site/pdf/Patent-Marking.pdf). ON Semiconductor reserves the right to make changes without further notice to any products herein. ON Semiconductor makes no warranty, representation or guarantee regarding the suitability of its products for any particular purpose, nor does ON Semiconductor assume any liability arising out of the application or use of any product or circuit, and specifically disclaims any and all liability, including without limitation special, consequential or incidental damages. Buyer is responsible for its products and applications using ON Semiconductor products, including compliance with all laws, regulations and safety requirements or standards, regardless of any support or applications information provided by ON Semiconductor. "Typical" parameters which may be provided in ON Semiconductor data sheets and/or specifications can and do vary in different applications and actual performance may vary over time. All operating parameters, including "Typicals" must be validated for each customer application by customer's technical experts. ON Semiconductor does not convey any license under its patent rights nor the rights of others. ON Semiconductor products are not designed, intended, or authorized for use as a critical component in life support systems or any FDA Class 3 medical devices or medical devices with a same or similar classification in a foreign jurisdiction or any devices intended for implantation in the human body. Should Buyer purchase or use ON Semiconductor products for any such unintended or unauthorized application, Buyer shall indemnify and hold ON Semiconductor and its officers, employees, subsidiaries, affiliates, and distributors harmless against all claims, costs, damages, and expenses, and reasonable attorney fees arising out of, directly or indirectly, any claim of personal injury or death associated with such unintended or unauthorized use, even if such claim alleges that ON Semiconductor was negligent regarding the design or manufacture of the part. ON Semiconductor is an Equal Opportunity/Affirmative Action Employer. This literature is subject to all applicable copyright laws and is not for resale in any manner.

## PUBLICATION ORDERING INFORMATION

### LITERATURE FULFILLMENT:

Literature Distribution Center for ON Semiconductor  
19521 E. 32nd Pkwy, Aurora, Colorado 80011 USA  
**Phone:** 303-675-2175 or 800-344-3860 Toll Free USA/Canada  
**Fax:** 303-675-2176 or 800-344-3867 Toll Free USA/Canada  
**Email:** [orderlit@onsemi.com](mailto:orderlit@onsemi.com)

**N. American Technical Support:** 800-282-9855 Toll Free  
USA/Canada  
**Europe, Middle East and Africa Technical Support:**  
Phone: 421 33 790 2910  
**Japan Customer Focus Center**  
Phone: 81-3-5817-1050

**ON Semiconductor Website:** [www.onsemi.com](http://www.onsemi.com)  
**Order Literature:** <http://www.onsemi.com/orderlit>  
For additional information, please contact your local  
Sales Representative