

NUMBER GS-20-0396	TYPE Application Specification		
TITLE Application Guide for Barklip R/A connector		PAGE 1 of 7	REVISION 5
		AUTHORIZED BY Terris Liu	DATE 18 Jan 16
CLASSIFICATION PRELIMINARY			

1.0 OBJECTIVE

This specification provides information and requirements regarding customer application of Barklip R/A connector. This specification is intended to provide general guidance for application process development. It is recognized that no single application process will work under all customer scenarios and that customers will develop their own application processes to meet their needs. However, if these application processes differ greatly from the one recommended, FCI cannot guarantee results.

2.0 SCOPE

This specification provides information and requirements regarding customer application of Barklip R/A connectors. These connectors provide a means of bringing high current from Bus Bar conductors to printed circuit boards or Bus Bar to Bus Bar.

3.0 GENERAL

This document is meant to be an application guide. If there is a conflict between the product drawings and specifications, the drawings take precedence.

4.0 DRAWINGS AND APPLICABLE DOCUMENTS

FCI PRODUCT SPECIFICATION GS-12-1179

Product drawings and **FCI's GS-12-1179** Product Specification are available at www.fci.com. In the event of a conflict between this application specification and the drawing, the drawing will take precedence. Customers are advised to refer to the latest revision level of FCI product drawings for appropriate details.

5.0 APPLICATION REQUIREMENTS

5.1.1 Connectors Mating Part (Bus Bar)

The Bus Bar Power Conductors shall comply with the following requirements:

Recommended material: Copper, solid blade

Material Thickness: 3.0±0.1 mm

Common stock width: 20.0 mm minimum

Smallest nominal pitch at contacting area: Solder type: 25 mm / Screw-mount type: 30mm

Pitch tolerance at connector area: ±1.0 mm (pitch tolerance includes twist and flatness)

Surface roughness in contact area: Ra 1.6 µm maximum

Plating in contact area: 3 µm min Silver over 1.27 µm min Nickel

Mating edges: 0.5 mm minimum, rounded or chamfered

5.1.2 General Application

Blind mate: this connector can handle adverse tolerances and allowing reliable mating to misaligned Bus Bar

Hot plug: it is hot plug capable for controlled and reliable separation of high power.

Bus Bar misalignment: ± 0.75 mm Max.

Mates directly to a single pole power Bus Bar

Ideal for high current Bus Bar power supply/distribution applications

NUMBER GS-20-0396	TYPE Application Specification		
TITLE Application Guide for Barklip R/A connector		PAGE 2 of 7	REVISION 5
		AUTHORIZED BY Terris Liu	DATE 18 Jan 16
CLASSIFICATION PRELIMINARY			

5.2 Connector Assembly To PC-Board

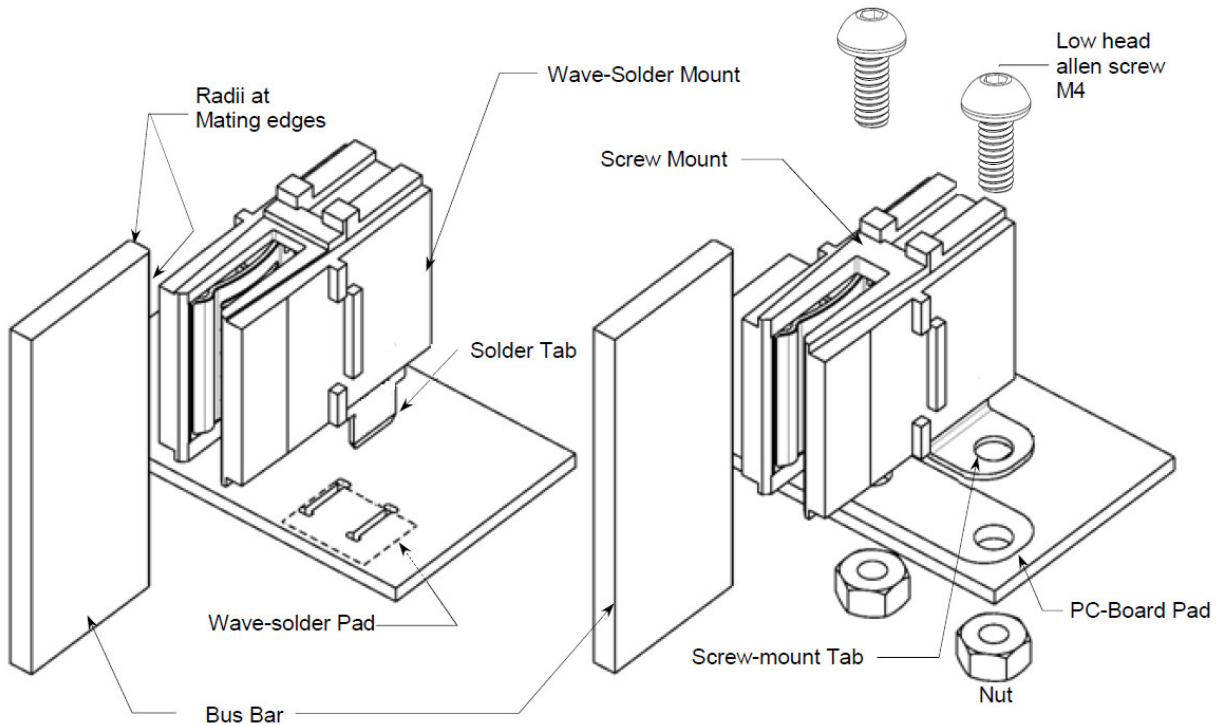

5.2.1 PC-Board General

Selected path-width and thickness shall be designed in such a way that the Barklip connector's maximum operation temperature is not exceeded during full current load.

5.2.2 Solder Connectors

a. Solder pads

Recommended PC-Board Wave-solder pad area is shown in following. Configuration and position of slots for the solder tails are shown in following as well.

b. PC-Board mounting pitch

The minimum applicable connector PC-Board mounting pitch is 25 ± 0.1 mm

NUMBER GS-20-0396	TYPE Application Specification		
TITLE Application Guide for Barklip R/A connector		PAGE 3 of 7	REVISION 5
		AUTHORIZED BY Terris Liu	DATE 18 Jan 16
CLASSIFICATION PRELIMINARY			

c. Board mounting

Solder contacts are designed for 4.8mm maximum PC-Board thickness.

To prevent damage caused by excessive bending of the PC-Board, the PC-Board shall be supported during insertion of the solder contacts in related PC-Board slots. Contacts shall be inserted until their shoulders rest against the PC-Board surface. This position shall be maintained during the soldering process in order to relief the solder-joints from any connector mating-peak force and comply to the PC-Board parallelism requirement.

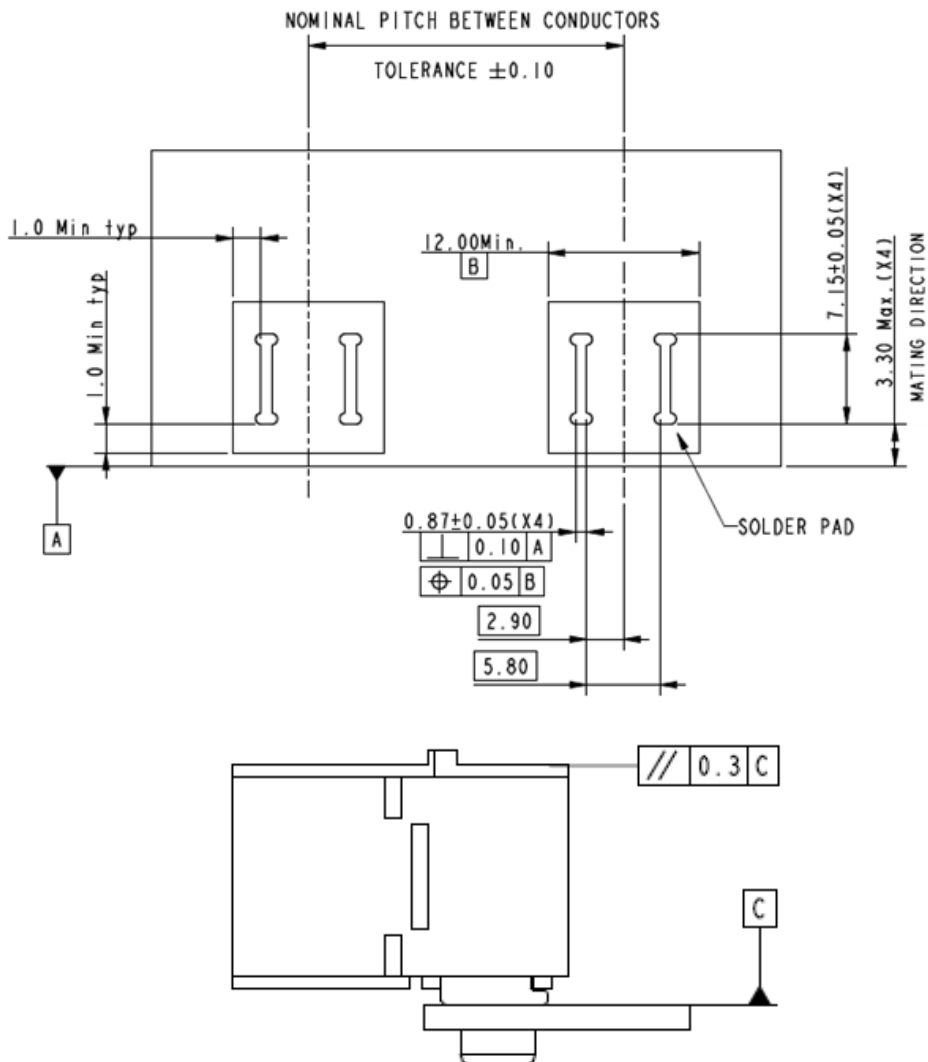

d. Solder process

The Solder temperature and dip duration shall not exceed the values specified in technical specification for wave soldering. The connector must be supported with a fixture during soldering process.

NUMBER GS-20-0396	TYPE Application Specification		
TITLE Application Guide for Barklip R/A connector		PAGE 4 of 7	REVISION 5
		AUTHORIZED BY Terris Liu	DATE 18 Jan 16
CLASSIFICATION PRELIMINARY			

5.2.3 Screw Mount Connectors

a. PC-Board Contact Pads

Recommended minimum PC-Board Contacting pad area and position of mounting holes are shown in following.

b. PC-Board Mounting Pitch

The minimum applicable connector PC-Board mounting pitch is 30 ± 0.1 mm.

c. PC-Board Screw Mounting

Recommended PC-Board thickness is 1.5~2.0mm.

Limited space between hole centerline of mounting-tab and housing-wall, requires that screws are pre-assembled to the mounting tabs, prior to sliding the screws into corresponding PC-Board holes. Applicable screws are: M4 Hex Allen Screws.

Assure that contacting surfaces of Connector tabs and PC-Board Pads are clean prior to assembly, to assure optimal current transfer.

Screw-mounting shall be established with 2.0N min torque in order to perform max rated current (ref Surface-pressure/Contact-area). It is recommended to apply washers and spring-washers to prevent loosening of the screw-fixation during multiple mating/unmating operations.

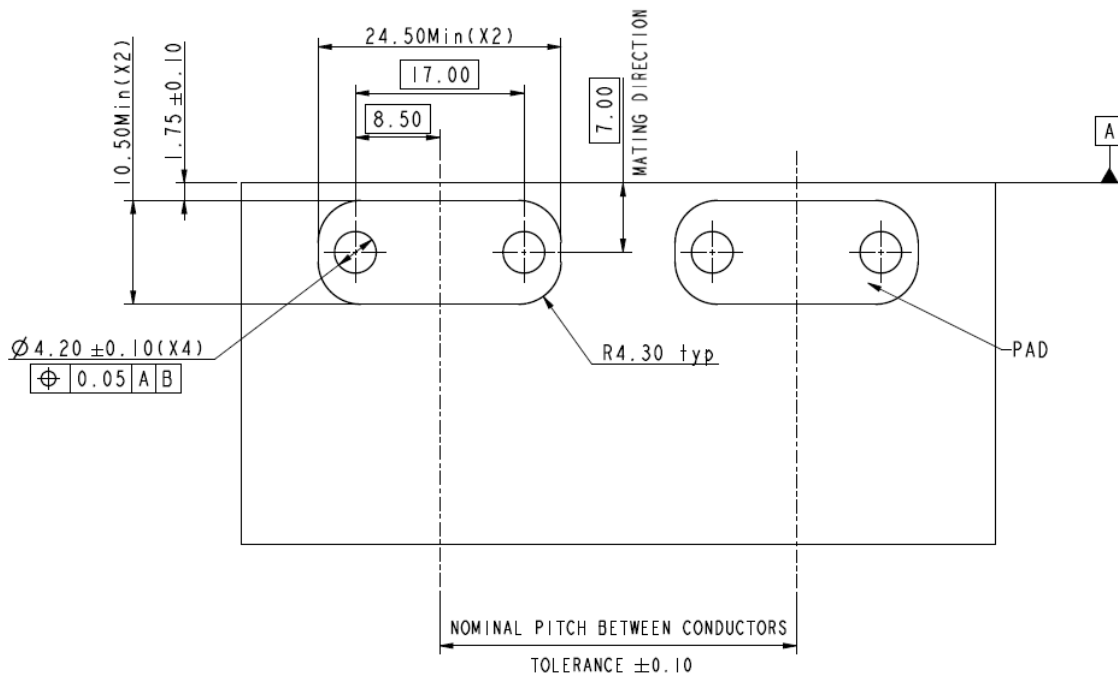

NUMBER GS-20-0396	TYPE Application Specification		
TITLE Application Guide for Barklip R/A connector		PAGE 5 of 7	REVISION 5
		AUTHORIZED BY Terris Liu	DATE 18 Jan 16
CLASSIFICATION PRELIMINARY			

5.2.4 Connector Mating

The connector shall preferably fully mate the Bus Bar until it bottoms in housing.
For multiple product in series application condition, The required insertion distance should be 1.30mm Max to ensure a reliable connection based on the dimension of Bus Bar chamfer is 1.00 ± 0.10 mm.

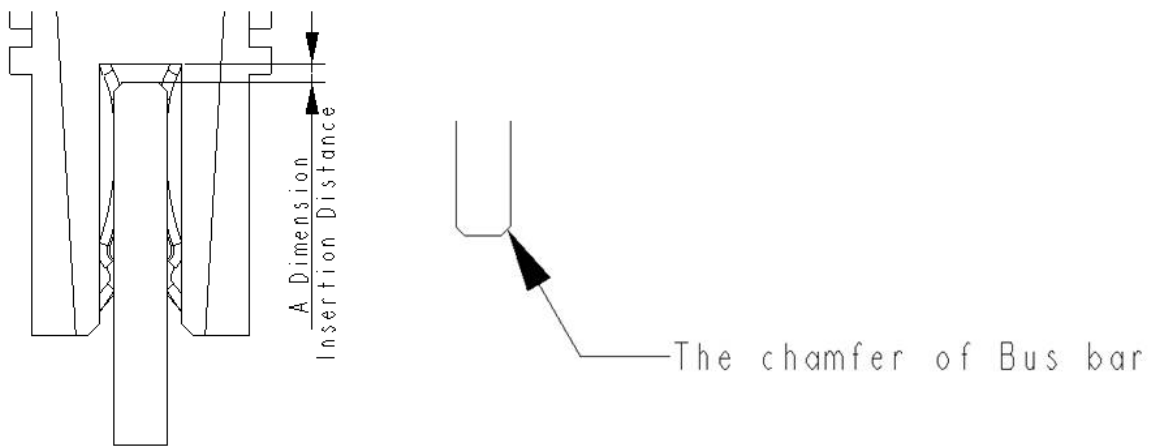

5.2.5 Connector Alignment

The connectors shall remain aligned after assembly and soldering, according to the perpendicularity requirements shown in following. These requirements are valid for the solder and the screw-mount version.

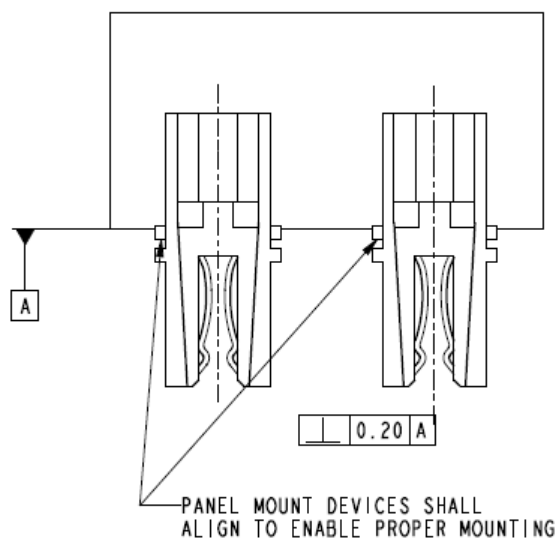

NUMBER GS-20-0396	TYPE Application Specification	FCI	
TITLE Application Guide for Barklip R/A connector		PAGE 6 of 7	REVISION 5
		AUTHORIZED BY Terris Liu	DATE 18 Jan 16
		CLASSIFICATION PRELIMINARY	

6.0 Explanation of uncommon or unusual characteristics

Spark spots at the contact entrance are not detrimental. This sacrificial area is designed as “first make / last break” –point, in order to prevent spark spots damage on the final contacting areas (situated deeper in the connector).

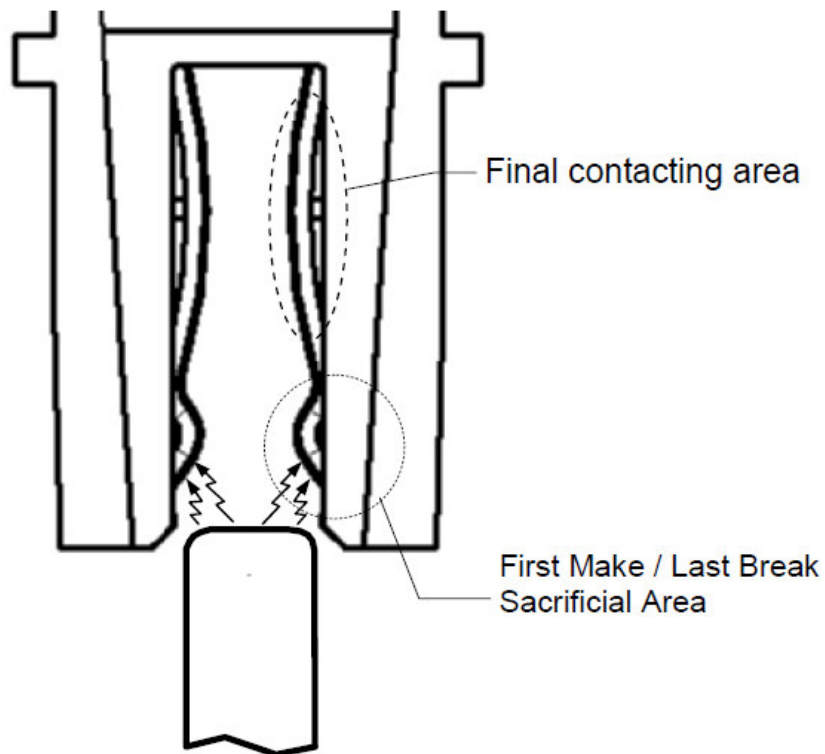

NUMBER GS-20-0396	TYPE Application Specification		
TITLE Application Guide for Barklip R/A connector		PAGE 7 of 7	REVISION 5
		AUTHORIZED BY Terris Liu	DATE 18 Jan 16
CLASSIFICATION PRELIMINARY			

7.0 RECORD RETENTION

<u>REV</u>	<u>PAGE</u>	<u>DESCRIPTION</u>	<u>EC#</u>	<u>DATE</u>
4	All	Preliminary release	TBD	2014-09-30
5	All	update item 5.2.4 Preliminary release	TBD	2016-01-18