

NUMBER GS-12-0956	TYPE PRODUCT SPECIFICATION		
TITLE AirMax VSe®, VS2® Connector System		PAGE 1 of 15	REVISION C
		AUTHORIZED BY Tao Zhan	DATE 2014-04-23
		CLASSIFICATION UNRESTRICTED	

AirMax VSe® Connector System

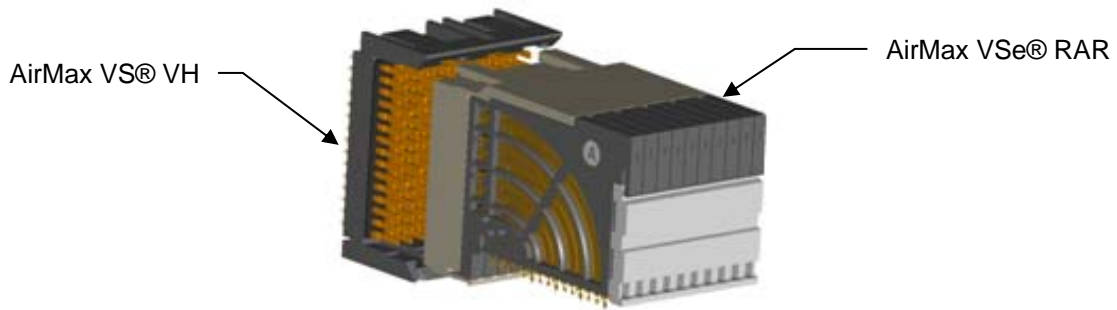

Backpanel Header with RAR on Daughter Card

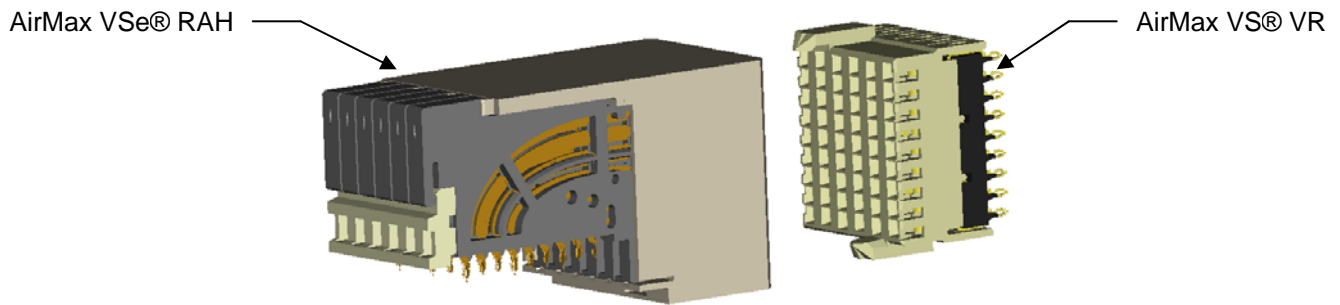

Backpanel Receptacle with RAH on Daughter Card

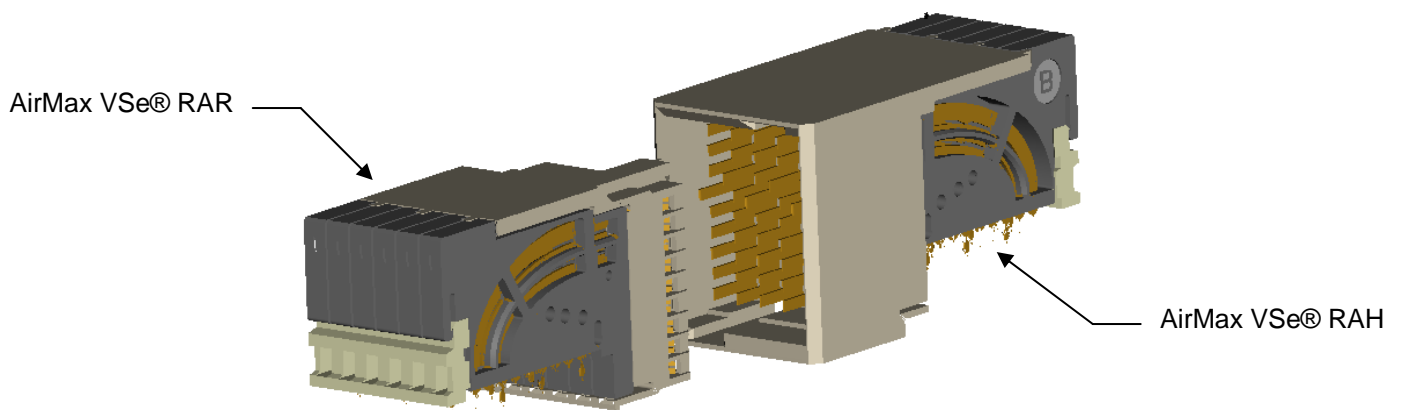

Co-Planar Assembly

NUMBER GS-12-0956	TYPE PRODUCT SPECIFICATION		
TITLE AirMax VSe®, VS2® Connector System		PAGE 2 of 15	REVISION C
		AUTHORIZED BY Tao Zhan	DATE 2014-04-23
		CLASSIFICATION UNRESTRICTED	

1.0	OBJECTIVE	3
2.0	SCOPE	3
3.0	RATINGS	3
4.0	APPLICABLE DOCUMENTS	3
4.1	FCI SPECIFICATIONS	3
4.2	INDUSTRY OR TRADE ASSOCIATION STANDARDS	3
4.3	NATIONAL OR INTERNATIONAL STANDARDS	4
4.4	FCI LABORATORY REPORTS	4
4.5	SAFETY AGENCY APPROVALS	4
5.0	REQUIREMENTS.....	4
5.1	QUALIFICATION	4
5.2	MATERIAL.....	4
5.3	FINISH	4
5.4	DESIGN AND CONSTRUCTION	4
6.0	ELECTRICAL CHARACTERISTICS.....	5
6.1	CONTACT RESISTANCE, LOW LEVEL	5
6.2	INSULATION RESISTANCE	5
6.3	DIELECTRIC WITHSTANDING VOLTAGE	5
6.4	CURRENT RATING.....	5
7.0	MECHANICAL CHARACTERISTICS	7
7.1	MATING/UN-MATING FORCE	7
7.2	COMPLIANT PIN INSERTION FORCE	7
7.3	COMPLIANT PIN RETENTION FORCE	7
7.4	PCB HOLE DEFORMATION RADIUS AND REMAINING CU PLATING THICKNESS	8
7.5	PCB HOLE WALL DAMAGE	8
8.0	ENVIRONMENTAL CONDITIONS.....	9
8.1	THERMAL SHOCK.....	9
8.2	CYCLICAL HUMIDITY AND TEMPERATURE.....	9
8.3	TEMPERATURE LIFE.....	9
8.4	MIXED FLOWING GAS CORROSION	9
8.5	SALT SPRAY.....	10
8.6	VIBRATION.....	10
8.7	MECHANICAL SHOCK.....	10
8.8	DURABILITY.....	10
8.9	DUST.....	10
8.10	DISTURB.	10
9.0	QUALITY ASSURANCE PROVISIONS	11
9.1	EQUIPMENT CALIBRATION	11
9.2	INSPECTION CONDITIONS.....	11
9.3	SAMPLE QUANTITY AND DESCRIPTION	11
9.4	ACCEPTANCE	11
9.5	QUALIFICATION TESTING	11
9.6	RE-QUALIFICATION TESTING.....	11
9.7	QUALIFICATION TEST TABLES.....	13
	REVISION RECORD.....	13

NUMBER GS-12-0956	TYPE PRODUCT SPECIFICATION		
TITLE AirMax VSe®, VS2® Connector System		PAGE 3 of 15	REVISION C
		AUTHORIZED BY Tao Zhan	DATE 2014-04-23
		CLASSIFICATION UNRESTRICTED	

1.0 Objective

This specification defines the performance, test, quality and reliability requirements of the AirMax VSe® press-fit product.

2.0 Scope

This specification is applicable to the AirMax VSe® press-fit family of products, which provides a high speed board-to-board interconnect for differential pairs and single-ended lines. Connectors include 3-pair, 4-pair and 5-pair backpanel RAR and 3-pair RAH on 2mm column pitch. For backpanel applications, the VSe® RAR will be mated to VS® VH or a VSe® RAH will be mated to a VS® VR. The test sequences defined in this specification meet the intent of Telcordia GR-1217-CORE requirements.

3.0 Ratings

- 3.1 Operating Voltage Rating = Less than 30 VAC (RMS)
- 3.2 Operating Current Rating = 0.5 Amps/contact with all contacts powered
- 3.3 Operating Temperature Range = -55° C to +85° C

4.0 Applicable Documents

4.1 FCI Specifications

4.1.1 Engineering drawings

- FCI product customer drawings (Various)
- FCI customer drawing 10104444 (Recommended Via Drill Sizes and Plating)

4.1.2 Process drawings

- FCI product inspection drawings (Various)

4.1.3 Application specification

- GS-20-0305 (AirMax VSe Connector System, press-fit products)

4.1.4 FCI Qualification Report

- EL-2011-12-030

4.2 Industry or Trade Association standards

Telcordia GR-1217-CORE (Separable Electrical Connectors Used in Telecommunications Hardware)

NUMBER GS-12-0956	TYPE PRODUCT SPECIFICATION		
AirMax VSe®, VS2® Connector System		PAGE 4 of 15	REVISION C
		AUTHORIZED BY Tao Zhan	DATE 2014-04-23
		CLASSIFICATION UNRESTRICTED	

4.3 National or International Standards

4.3.1 Flammability: UL94V-0 or similar applicable specification

4.3.2 EIA 364: Electrical Connector/Socket Test Procedures Including Environmental Classifications.

4.3.3 IEC 60512: Connectors for Electronic Equipment – Tests and Measurement

4.4 FCI Laboratory Reports

- To be added when available

4.5 Safety Agency Approvals

- To be added when available

5.0 Requirements

5.1 Qualification

Connectors furnished under this specification shall be capable of meeting the qualification test requirements specified herein.

5.2 Material

The material for each component shall be as specified herein or equivalent.

- Contacts: Copper alloy

- Housings and IMLAs: High temperature thermoplastic; UL 94V-0 compliant

5.3 Finish

The finish for applicable components shall be as specified herein or equivalent.

- Contact Areas: Performance-based plating, qualified to meet the requirements of this specification, including Telcordia GR-1217-CORE (November 1995) Central Office test sequence

- Press-Fit Tails: Tin or Tin-Lead over Nickel

5.4 Design and Construction

Connectors shall be of the design, construction, and physical dimensions specified on the applicable product drawing. There shall be no cracks, burrs, or other physical defects that may impair performance.

NUMBER GS-12-0956	TYPE PRODUCT SPECIFICATION		
TITLE AirMax VSe®, VS2® Connector System		PAGE 5 of 15	REVISION C
		AUTHORIZED BY Tao Zhan	DATE 2014-04-23
		CLASSIFICATION UNRESTRICTED	

6.0 Electrical Characteristics

6.1 Contact Resistance, Low Level (LLCR) – EIA 364-23

The low level contact resistance shall not initially exceed 60 milliohms (Backplane) or 120 milliohms (Coplanar). The low level contact resistance shall also not exceed 10 milliohms increase in resistance (from the initial measurement) after any treatment and/or environmental exposure.

The following details shall apply:

- a. Test Voltage - 20 milli-volts DC max open circuit.
- b. Test Current - Not to exceed 100 milli-amperes.
- c. Number of readings: 500 minimum

6.2 Insulation Resistance – EIA 364-21

The insulation resistance of mated connectors shall not be less than 1000 M-ohms.

The following details shall apply:

- a. Test Voltage - 500 volts DC (Sig-Sig & Sig-Grd), 200 volts DC (Grd-Grd)
- b. Electrification Time – 60 seconds.
- c. Points of Measurement - Between adjacent contacts and between ground contacts within a column
- d. Number of readings: 30 (10 readings per loose-piece connector set)

6.3 Dielectric Withstanding Voltage – EIA 364-20

There shall be no evidence of arc-over, insulation breakdown, or excessive leakage current > 0.5 mA.

The following details shall apply:

- a. Test Voltage – 500 volts (Sig-Sig & Sig-Grd), 200 volts (Grd-Grd) AC RMS, 60Hz.
- b. Test Duration - 60 seconds.
- c. Test Condition - 1 (760 Torr - sea level).
- d. Points of Measurement - Between adjacent contacts and ground contacts within a column.
- e. Number of readings: 30 (10 readings per loose-piece connector set)

6.4 Current Rating – EIA 364-70

The temperature rise above ambient shall not exceed 30 deg C at any point in the system when all contacts are powered at 0.5 Amps

The following details shall apply:

- a. Ambient Conditions – Still air at 25°C
- b. Thermocouple location - mechanically attached to the base of the header mating contacts
- c. Copper trace weight: -1 oz

NUMBER GS-12-0956	TYPE PRODUCT SPECIFICATION		
AirMax VSe®, VS2® Connector System		PAGE 6 of 15	REVISION C
		AUTHORIZED BY Tao Zhan	DATE 2014-04-23
		CLASSIFICATION UNRESTRICTED	

- d. Quantity and location of thermocouples - 3 minimum (2 on interior column positions and 1 on an exterior column position)

NUMBER GS-12-0956	TYPE PRODUCT SPECIFICATION		
TITLE AirMax VSe®, VS2® Connector System		PAGE 7 of 15	REVISION C
		AUTHORIZED BY Tao Zhan	DATE 2014-04-23
		CLASSIFICATION UNRESTRICTED	

7.0 Mechanical Characteristics

7.1 Mating/Un-mating Force – EIA 364-13

The force to mate a receptacle connector and compatible AirMax VS® stitched header shall not exceed 0.50 N per contact. The un-mating force shall not be less than 0.15 N per contact.

The following details shall apply:

- a. Cross Head Speed – 25.4 mm per minute.
- b. Utilize free floating fixtures.
- c. Number of mate/un-mate cycles: 3

7.2 Compliant Pin Insertion Force – EIA 364-05

Fully populated connectors shall be applied to test boards in accordance with the AirMax VSe application specification GS-20-0305. Testing shall consist of two test groups in which three samples are inserted and withdrawn into the same test board in order to simulate connector repair cycles. The following details shall apply:

- a. Average force to insert one small EON (0.4mm PCB hole): 15 N maximum
- b. Average force to insert one standard EON (0.5mm PCB hole): 30 N maximum
- c. Number of connector assemblies to be tested: 6 (2 test groups, 3 samples each)
- d. Number of readings: 1 per connector assembly tested
- e. Test boards: Nominal diameter finished holes [Ø0.40 mm (small) and Ø0.50 mm (standard)] with immersion tin plating.
- f. Measure and record the test board's finished hole sizes prior to performing test.

7.3 Compliant Pin Retention Force – EIA 364-05

Fully populated connectors shall be removed from test boards in accordance with AirMax VSe application specification GS-20-0305. Testing shall consist of two test groups in which two samples are inserted and withdrawn from the same test board in order to simulate connector repair cycles. The following details shall apply:

- a. Average force to remove one small EON (0.4mm PCB hole): 3.6 N minimum
- b. Average force to remove one standard EON (0.5mm PCB hole): 4.5 N minimum
- c. Number of connector assemblies to be tested: 4 (2 test groups, 2 samples each)
- d. Number of readings: 1 per connector assembly tested
- e. Test boards: Nominal diameter finished holes [Ø0.40 mm (small) and Ø0.50 mm (standard)] with immersion tin plating.

NUMBER GS-12-0956	TYPE PRODUCT SPECIFICATION		
TITLE AirMax VSe®, VS2® Connector System		PAGE 8 of 15	REVISION C
		AUTHORIZED BY Tao Zhan	DATE 2014-04-23
		CLASSIFICATION UNRESTRICTED	

7.4 PCB Hole Deformation Radius and Remaining Cu Plating Thickness (compliant pin) – EIA 364-96

Use PCB's with 0.40 mm (signal) and 0.50 mm (ground) diameter finished holes, with immersion tin plating, and 2.4 mm minimum overall thickness. Metallographic cross-sections shall be prepared parallel to the PCB surface (transverse section) to facilitate radial hole deformation measurement, photographs, and remaining Cu plating measurement.

Prior to cross-section preparation, perform 3 compliant pin insertions and 2 compliant pin withdrawals.

The measurements and photographs shall be performed at 0.3 mm, from the connector side PCB laminate (not copper) surface and at the center of the compliant pin section on a minimum of 10 holes of each size. The average (of 10 holes for each size) hole deformation radius shall be no greater than 37.5 µm when measured from the drilled hole. The absolute maximum deformation radius shall not exceed 50 µm. The minimum average (of 10 holes for each size) copper thickness remaining between the compliant pin and the printed wiring board laminate shall not be less than 7.5 µm.

7.5 PCB Hole Wall Damage – EIA 364-96

Use PCB's with 0.40 mm (signal) and 0.50 mm (ground) diameter finished holes, with immersion tin plating, and 2.4 mm minimum overall thickness. Metallographic cross-sections shall be prepared perpendicular to the PCB surface (longitudinal section) and through the compliant section wear track to facilitate examination of the PTH.

Prior to cross-section preparation, perform 3 compliant pin insertions and 2 compliant pin withdrawals.

There shall be no copper cracks, separations between conductive interfaces, or laminate-to-copper separations. Inspect 10 pins/holes of each diameter.

NUMBER GS-12-0956	TYPE PRODUCT SPECIFICATION		
TITLE AirMax VSe®, VS2® Connector System		PAGE 9 of 15	REVISION C
		AUTHORIZED BY Tao Zhan	DATE 2014-04-23
		CLASSIFICATION UNRESTRICTED	

8.0 Environmental Conditions

After exposure to the following environmental conditions in accordance with the specified test procedure and/or details, the product shall show no physical damage and shall meet the electrical and mechanical requirements per paragraphs 6.0 and 7.0 as specified in the Table 1 test sequences. Unless specified otherwise, assemblies shall be mated during exposure.

8.1 Thermal Shock – EIA 364-32.

- a. Number of Cycles - 5
- b. Temperature Range - Between -55°C and +85° C
- c. Time at Each Temperature - 30 minutes minimum
- d. Transfer Time - 30 seconds, maximum

8.2 Cyclical Humidity and Temperature – EIA 364-31 method III. Samples are to be subjected to 50 cycles of 10-hour duration for a total of 500 hours.

A cycle consists of the following steps:

- a. 2 hour ramp from 25°C at 80%-98% RH to 65°C at 90%-98% RH
- b. 4 hour dwell at 65°C at 90%-98% RH
- c. 2 hour ramp down to 25°C at 80%-98% RH
- d. 2 hour dwell at 25°C at 80%-98% RH

8.3 Temperature Life – EIA 364-17. Headers and receptacles shall remain mated without any electrical load

- a. Test Temperature - 85° C
- b. Test Duration – 500 hours

8.4 Mixed Flowing Gas corrosion (MFG) – EIA 364-65, class IIA, 4-gas

- a. Duration – 20 days
- b. Temperature – 30°C
- c. Humidity – 70%
- d. Un-mated backpanel connectors are to be exposed to gas mixture for 10 days, then mated and exposed for an additional 10 days. Coplanar, each gender shall be exposed for 10 days, then mated to unexposed connectors for an additional 10 days.
- e. Gas compositions, per Central Office requirements:

<u>Gas Type</u>	<u>Gas Concentration</u>
NO ₂	200 ppb
Cl ₂	10 ppb
H ₂ S	10 ppb
SO ₂	100 ppb

NUMBER GS-12-0956	TYPE PRODUCT SPECIFICATION		
AirMax VSe®, VS2® Connector System		PAGE 10 of 15	REVISION C
		AUTHORIZED BY Tao Zhan	DATE 2014-04-23
		CLASSIFICATION UNRESTRICTED	

- 8.5 Salt Spray – EIA 364-26
 - a. Test Condition - A
 - b. Duration – 96 hours
 - c. Samples shall be mated during salt exposure

- 8.6 Vibration – EIA 364-28, Test Condition II
 - a. Vibration Amplitude – 1.5 mm double amplitude or 10G acceleration
 - b. Frequency Range - 10 to 500 to 10 hertz
 - c. Sweep Time and Duration – 15 minutes per sweep, 8 hours along each of three orthogonal axes (24 hours total)
 - d. Mounting - Rigidly mount assemblies
 - e. No discontinuities greater than 1 microsecond

- 8.7 Mechanical Shock – EIA 364-27, Test Condition H
 - a. Amplitude – half sine 30G
 - b. Duration – 11 milliseconds
 - c. Shocks - 3 shocks along each of three orthogonal axes (18 shocks total)
 - d. Mounting - Rigidly mount assemblies
 - e. LLCR readings – Take LLCR measurements after shock in each axis
 - f. No discontinuities greater than 1 microsecond

- 8.8 Durability - EIA 364-09
 - a. Number Cycles – See table 1 (200 total mating cycles)
 - b. Cycling Rate – 127 mm/min.
 - c. Use free floating fixtures

- 8.9 Dust – EIA 364-91
 - a. Samples to be exposed to one-hour dust exposure
 - b. Using a benign dust composition number 1
 - c. Only unmated backpanel connectors shall be exposed to dust. For co-planar applications, both connectors shall be exposed to dust and then mated to unexposed connectors.

- 8.10 Disturb - Perform in accordance with Telcordia GR-1217-CORE, November 1995, section 9.1.3.3 paragraph 7. The mated connectors shall be subjected to an interface disturbance that consists of slightly un-mating the sample approximately 0.10 mm. The sample is then reseated and measurements are taken.

NUMBER GS-12-0956	TYPE PRODUCT SPECIFICATION		
TITLE AirMax VSe®, VS2® Connector System		PAGE 11 of 15	REVISION C
		AUTHORIZED BY Tao Zhan	DATE 2014-04-23
		CLASSIFICATION UNRESTRICTED	

9.0 Quality Assurance Provisions

9.1 Equipment Calibration

All test equipment and inspection facilities used in the performance of any test shall be maintained in a calibration system in accordance with ANSI Z-540 and ISO 9000.

9.2 Inspection Conditions

Unless otherwise specified herein, all inspections shall be performed under the following ambient conditions:

- a. Temperature: 25 +/- 5 deg C
- b. Relative Humidity: 30% to 60%
- c. Barometric Pressure: Local ambient

9.3 Sample Quantity and Description

The test sequences for qualification testing are shown in table 1 and the connector sample sizes for 5-pair connectors is shown in Table 2. The number of readings is specified in the description for each test. For connector sizes with fewer contacts than 5-pair connectors, additional samples may be required to meet the minimum number of readings for specific tests.

9.4 Acceptance

- a. Electrical and mechanical requirements placed on test samples as indicated in paragraphs 6.0 and 7.0 shall be established from test data using appropriate statistical techniques or shall otherwise be customer specified, and all samples tested in accordance with this product specification shall meet the stated requirements.
- b. Failures attributed to equipment, test setup, or operator error shall not disqualify the product. If product failure occurs, corrective action shall be taken and samples resubmitted for qualification.

9.5 Qualification Testing

Qualification testing shall be performed on sample units produced with equipment and procedures normally used in production. The test sequences shall be as shown in the qualification test table. Data shall be provided with the samples noting production history: production lot codes for components and assemblies, print revisions for components and assemblies, and plating composition and thickness.

9.6 Re-Qualification Testing

If any of the following conditions occur, the responsible product engineer shall initiate requalification testing consisting of all applicable parts of the qualification test matrix.

- a. A significant design change is made to the existing product which impacts the product form, fit or function. Examples of significant changes shall include, but not be limited to, changes in the plating material composition or thickness, contact force, contact surface geometry, insulator design, contact base material, or contact lubrication requirements.
- b. A significant change is made to the manufacturing process which impacts the product form, fit or function.

NUMBER GS-12-0956	TYPE PRODUCT SPECIFICATION		
AirMax VSe®, VS2® Connector System		PAGE 12 of 15	REVISION C
		AUTHORIZED BY Tao Zhan	DATE 2014-04-23
		CLASSIFICATION UNRESTRICTED	

- c. A significant event occurs during production or end use requiring corrective action to be taken relative to the product design or manufacturing process.

NUMBER GS-12-0956	TYPE PRODUCT SPECIFICATION		
TITLE AirMax VSe®, VS2® Connector System		PAGE 13 of 15	REVISION C
		AUTHORIZED BY Tao Zhan	DATE 2014-04-23
CLASSIFICATION UNRESTRICTED			

9.7 Qualification Test Tables – See note 4

TEST GROUP ID ►		P ¹	1	2	3a	3b	4 ²	5 ³	6	7
TEST DESCRIPTION	SECTION	Design Verification for Product Extension	Mixed Flowing Gas	Temp Life	Thermal Shock & Humidity	Thermal Shock & Humidity	Vibration & Mech. Shock	Press-Fit Evaluation & Mating / Un-mating Forces	Salt Spray	Current Rating
DESIGN AND CONSTRUCTION	5.4	1,7	1,16	1,5	1,11	1,14	1,14	1	1,5	1,3
MATE HEADER AND RECEPTACLE	--	2	2,8		2	2,10	2,8			
UN-MATE HEADER AND RECEPTACLE	--		6			8	6			
ELECTRICAL:										
LOW LEVEL CONTACT RESISTANCE	6.1	4,6	3,5,9,11,13,15	2,4		3,5,7,11,13	3,5,9,11,13		2,4	
INSULATION RESISTANCE	6.2				3,6,9					
DIELECTRIC WITHSTANDING VOLTAGE	6.3				4,7,10					
CURRENT RATING	6.4									2
MECHANICAL:										
MATING / UN-MATING FORCE	7.1	3						7		
COMPLIANT PIN INSERTION FORCE	7.2							2,4,6		
COMPLIANT PIN RETENTION FORCE	7.3							3,5		
PCB HOLE DEFORMATION RADIUS	7.4							8		
PCB WALL DAMAGE	7.5							9		
ENVIRONMENTAL:										
THERMAL SHOCK	8.1				5	4				
CYCLICAL HUMIDITY & TEMPERATURE	8.2				8	12				
TEMPERATURE LIFE	8.3			3						
MFG, UN-MATED , 10-DAYS	8.4		7							
MFG, MATED, 10-DAYS	8.4		10							
SALT SPRAY	8.5								3	
VIBRATION	8.6						10			
MECHANICAL SHOCK	8.7						12			
DURABILITY, 99-CYCLES	8.8	5	4,14			6	4			
DUST CONTAMINATION	8.9					9	7			
DISTURB	8.10		12							

Table 1: Qualification Test Matrix

NUMBER GS-12-0956	TYPE PRODUCT SPECIFICATION		
TITLE AirMax VSe®, VS2® Connector System		PAGE 14 of 15	REVISION C
		AUTHORIZED BY Tao Zhan	DATE 2014-04-23
		CLASSIFICATION UNRESTRICTED	

TEST GROUP ID ►	P ¹	1	2	3a	3b	4 ²	5 ³	6	7
COMPONENT DESCRIPTION	Design Verification for Product Extension	Mixed Flowing Gas	Temp Life	Thermal Shock & Humidity	Thermal Shock & Humidity	Vibration & Mech. Shock	Press-Fit Evaluation & Mating / Un-mating Forces	Salt Spray	Current Rating
Number of receptacles	4	4	4	3	4	4	6	4	3
Number of headers	4	4	4	3	4	4	2	4	3
LLCR Board Sets	4	4	4		4	3		4	
Continuity Board Set						1			3
Receptacle Mechanical Boards							2		
Header Mechanical Boards							2		

Table 2: Qualification Sample Requirements

Notes:

1. Group P is not required for a full qualification. Group P is a design verification sequence for product extensions after a full qualification has been completed.
2. For test group 4, LLCR is measured on 3 sample sets and one set is used for discontinuity monitoring.
3. For test group 5, only the receptacle connector needs to be tested for compliant pin insertion and withdrawal forces and cross sectioned for the PCB hole wall damage / deformation requirements. Headers have been previously qualified per FCI product specification GS-12-239.

NUMBER GS-12-0956	TYPE PRODUCT SPECIFICATION		
TITLE AirMax VSe®, VS2® Connector System		PAGE 15 of 15	REVISION C
		AUTHORIZED BY Tao Zhan	DATE 2014-04-23
		CLASSIFICATION UNRESTRICTED	

REVISION RECORD

<u>Rev</u>	<u>Page</u>	<u>Description</u>	<u>Date</u>
A	All	Initial Release	2012-02-09
B	6	Modified the requirement for mating force (section 7.1)	2012-06-21
C	All	Add VS2 connector, Modified the operating voltage rating and trade mark, Compliant Pin Insertion Force & retention force (section 3.0, 7.2 & 7.3)	2014-04-23