

THIS DOCUMENT IS THE EXCLUSIVE PROPERTY OF INLINE FILLING SYSTEMS AND MAY NOT BE USED OR REPRODUCED, NOR ITS CONTENT OR PART THERE OF BE DISCUSSED TO OTHER BY ANY PERSON OR COMPANY WITHOUT THE WRITTEN CONSENT FROM INLINE FILLING SYSTEMS

REV #	ECN #	DESCRIPTION	DATE	INIT
-------	-------	-------------	------	------

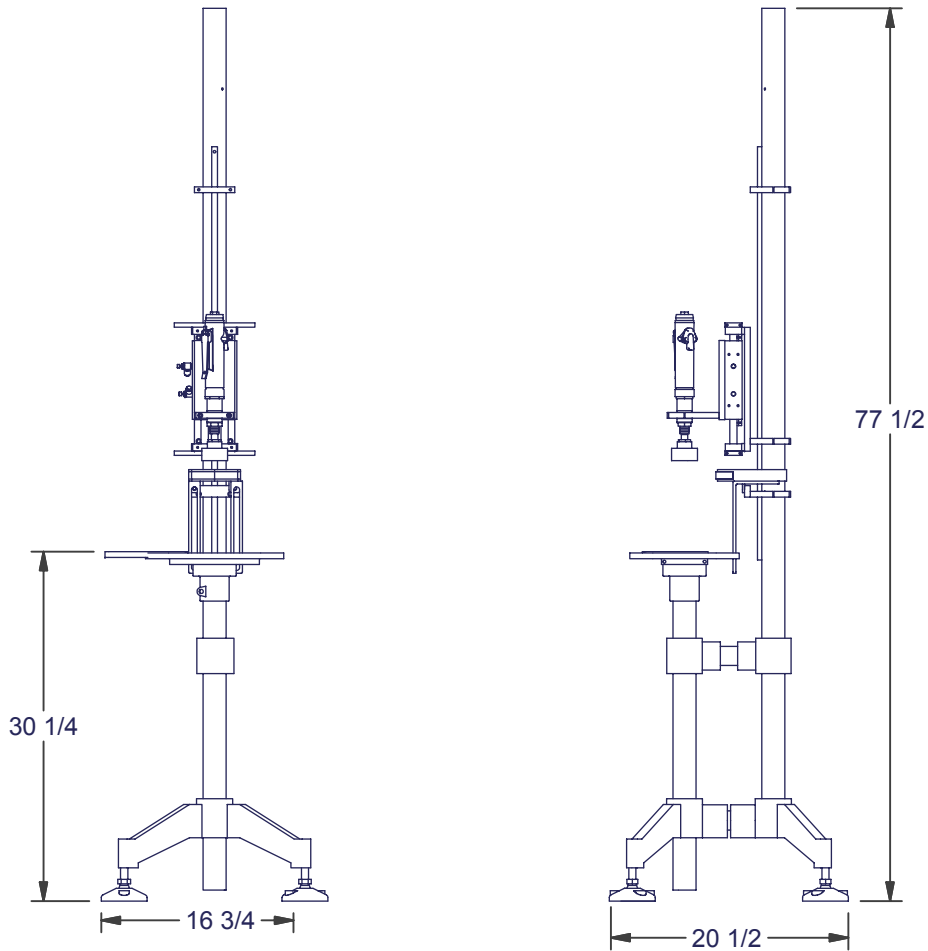

DRAWN BY: KEN M	DATE: 12/13/2005	CHECKED BY:	MATERIAL:
--------------------	---------------------	-------------	-----------

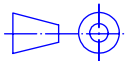

DECIMALS / DECIMAUX: .xx ± .01
 DECIMALS / DECIMAUX: .xxx ± .005
 FRACTIONS / FRACTIONS: ± 1/32
 ANGULAR / ANGULAIRE: ± 0.5°
 BREAK ALL SHARP EDGES /
 BRISER TOUTES LES ARRETES

MAT'L TREATMENT:	MAT'L #:
------------------	----------



216 S. SEABOARD AVE. TEL: (941) 486-8800
 VENICE, FLORIDA FAX: (941) 486-0077
 USA 34292 EMAIL: sales@fillers.com

MACHINE: SEMI AUTO INLINE CAPPER	SHEET: 1 OF 1
----------------------------------	------------------

TITLE: SEMI-AUTO CAPPER ASSEMBLY

DWG NO: F:\ENGINEERING\PRODUCT DRAWINGS\CAPPER	REV: 2
--	-----------

BENCHTOP.iam